



**Electronica***Veneta*

CATALOGUE No. 26-D  
**AUTOMATION  
TECHNOLOGIES**







CATALOGUE No. 26-D  
**AUTOMATION  
TECHNOLOGIES**

**Automation  
technologies**

[export@elettronicaveneta.com](mailto:export@elettronicaveneta.com)  
[www.elettronicaveneta.com](http://www.elettronicaveneta.com)

26D-E  
Rel. F15



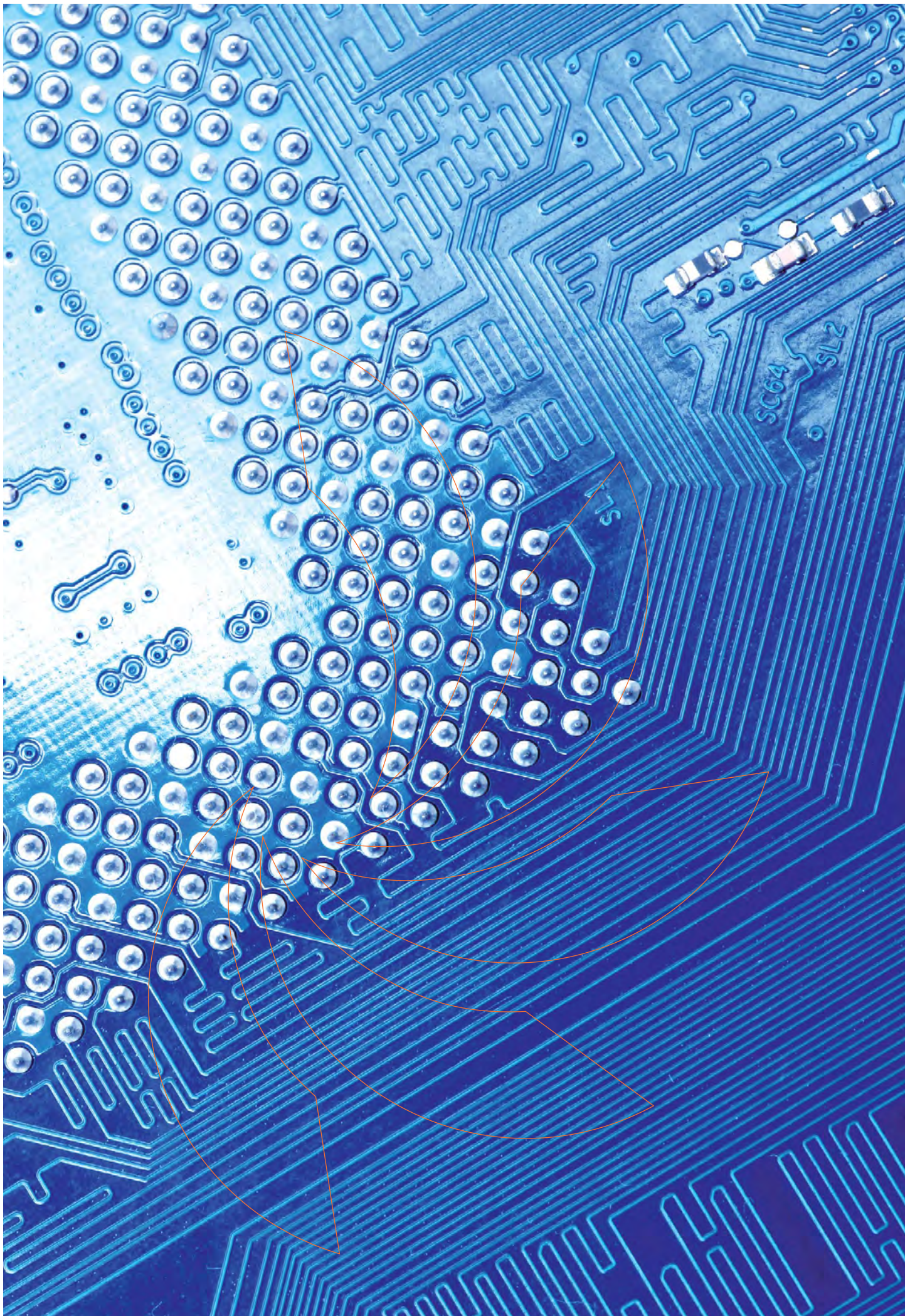



### GENERAL INTRODUCTION

1

### PRESENTATION

2

## PNEUMATICS

### PNEUMATICS

BASIC PNEUMATICS TRAINER  
 ADVANCED PNEUMATICS KIT  
 PNEUMATICS STUDENT TRAINER  
 PNEUMATICS PROFESSOR TRAINER  
 PNEUMATICS CUT-AWAY COMPONENTS

Mod. ALPE-BC/EV  
 Mod. ALPE-AD/EV  
 Mod. SPT/EV  
 Mod. PPT/EV  
 Mod. VCPE/EV

### PN

PN 5  
 PN 7  
 PN 8  
 PN 9  
 PN 10

### ELECTRO-PNEUMATICS

BASIC ELECTRO-PNEUMATICS TRAINER  
 ADVANCED ELECTRO-PNEUMATICS KIT  
 BASIC ELECTRO-PNEUMATICS KIT  
 ELECTRO-PNEUMATIC ACTUATORS TRAINER  
 SET OF POSTERS ON PNEUMATICS AND ELECTRO-PNEUMATICS  
 PROXIMITY SENSORS TRAINER  
 ARTIFICIAL COLOUR VISION SYSTEM

Mod. ALEP-BC/EV  
 Mod. ALEP-AD/EV  
 Mod. KALEP/EV  
 Mod. EAT/EV  
 Mod. POS-PE/EV  
 Mod. ALP-PSX/EV  
 Mod. AVS-1/EV

PN 13  
 PN 14  
 PN 15  
 PN 16  
 PN 17  
 PN 18  
 PN 20

### PROPORTIONAL PNEUMATICS

SINGLE-LOOP PID DIGITAL CONTROLLER  
 PROPORTIONAL ELECTRO-PNEUMATICS KIT -  
 LINEAR POSITION CONTROL  
 ELECTRO-PNEUMATICS KIT -  
 SPEED CONTROL OF A PNEUMATIC MOTOR  
 ELECTRO-PNEUMATICS KIT -  
 FLOW CONTROL IN A PNEUMATIC LINE

Mod. SLC/EV  
 Mod. ALP-PROL/EV  
 Mod. ALP-PROV/EV  
 Mod. ALP-PROF/EV

PN 23  
 PN 24  
 PN 25  
 PN 26

## OIL-HYDRAULICS - ELECTRO OIL-HYDRAULICS - PROPORTIONAL OIL-HYDRAULICS

OIL-HYDRAULICS PRACTICAL SYSTEM  
 OIL-HYDRAULICS POWER UNIT  
 ELECTRO-OIL-HYDRAULICS PRACTICAL SYSTEM  
 PROPORTIONAL OIL-HYDRAULICS PRACTICAL SYSTEM  
 WORK-BENCH  
 OIL-HYDRAULICS PROFESSOR TRAINER  
 SUPPLEMENTARY MODULAR PANELS  
 PROPORTIONAL OIL-HYDRAULIC COMPONENTS  
 OIL-HYDRAULICS STUDENT TRAINER  
 SUPPLEMENTARY MODULAR PANELS  
 PROPORTIONAL OIL-HYDRAULIC COMPONENTS  
 TRANSPARENT OIL-HYDRAULIC COMPONENTS

Mod. KMO/EV  
 Mod. CO/EV  
 Mod. KMEO/EV  
 Mod. KMOP/EV  
 Mod. WT/EV - WT2/EV  
 Mod. HPT/EV  
 Mod. SMP-P/EV  
 Mod. HPV-P/EV  
 Mod. HST/EV  
 Mod. SMP-S/EV  
 Mod. HPV-S/EV  
 Mod. HVS/EV

### HY

HY 5  
 HY 6  
 HY 7  
 HY 8  
 HY 9  
 HY 10  
 HY 12  
 HY 13  
 HY 14  
 HY 16  
 HY 17  
 HY 18

## PLC - SIMULATORS AND APPLICATIONS

### PLC TRAINING PANELS

PLC TRAINING PANEL	Mod. PLC-V6/EV	PL 5
PLC TRAINING PANEL	Mod. PLC-V7/EV	PL 7
PLC TRAINING PANEL	Mod. PLC-V8/EV	PL 9
INTELLIGENT LOGIC MODULE	Mod. ILM-V1/EV	PL 11
TOUCHSCREEN OPERATOR PANEL	Mod. T7-IOP/EV	PL 13
TOUCHSCREEN OPERATOR PANEL	Mod. T8-IOP/EV	PL 14
DCS PROCESS CONTROL SYSTEM	Mod. PCS-7/EV	PL 15

### SIMULATORS OF PLC-PROGRAMMED SYSTEMS

PROGRAMMABLE SYSTEMS SIMULATOR	Mod. SSP-1/EV	PL 18
--------------------------------	---------------	-------

### SIMULATORS OF PLC-CONTROLLED INDUSTRIAL PROCESS

PROCESS SIMULATOR FOR MOLDING PLASTIC MATERIALS	Mod. IMS/EV	PL 21
IRON PROCESS SIMULATOR	Mod. SPS/EV	PL 23
PACKAGING PROCESS SIMULATOR	Mod. PPS/EV	PL 25

### PLC-CONTROLLED APPLICATIONS

ADVANCED 3-FLOOR LIFT	Mod. HM-410/EV	PL 28
BASIC 3-FLOOR LIFT	Mod. LDIDA/EV	PL 30

## PROCESS CONTROLS

MODULAR AUTOMATIC PROCESS CONTROLS	Mod. APC-900/EV	PC 5
FOUR LOOPS PID DIGITAL CONTROLLER	Mod. PID-S1/EV	PC 8
PROCESS CONTROL MULTIVARIABLE SYSTEM	Mod. FLTP/EV	PC 10
<b>BENCH-TOP UNITS (ON-BOARD PLC):</b>		
FLOW-RATE CONTROL	Mod. FCBp/EV	PC 12
LEVEL CONTROL	Mod. LCBp/EV	PC 14
PRESSURE CONTROL	Mod. PCBp/EV	PC 16
TEMPERATURE CONTROL	Mod. TCBp/EV	PC 18
pH CONTROL	Mod. pHCBp/EV	PC 20

## MECHATRONICS

### MODULES

PIECE IDENTIFICATION AND DISTRIBUTION MODULE	Mod. MCS-500/EV	ME 5
PIECES DISTRIBUTION MODULE	Mod. MCS-505/EV	ME 6
SWIVEL ARM AND MANIPULATOR MODULE	Mod. MCS-510/EV	ME 7
PIECES THICKNESS MEASUREMENT MODULE	Mod. MCS-520/EV	ME 8
LINEAR STORAGE MODULE	Mod. MCS-530/EV	ME 9
ROTARY INDEXING TABLE MODULE	Mod. MCS-570/EV	ME 10
ELECTRIC PICK AND PLACE MODULE	Mod. MCS-580/EV	ME 11
PNEUMATIC ARM MODULE	Mod. MCS-590/EV	ME 12
DRILLING STATION MODULE	Mod. MCS-600/EV	ME 13
ROTATIVE STORAGE MODULE	Mod. MCS-610/EV	ME 14
CARTESIAN CONTROL STORAGE MODULE	Mod. MCS-620/EV	ME 15
CONVEYOR MODULE	Mod. MCS-700/EV	ME 16
ROBOT MODULE	Mod. MCS-710/EV	ME 17
MODULE FOR TESTING AND SELECTING PIECES	Mod. MCS-720/EV	ME 18
WEIGHTING MODULE	Mod. MCS-730/EV	ME 19
STORAGE MODULE FOR PRISMATIC PIECES	Mod. MCS-740/EV	ME 20
BOX OF TOOLS AND WORKPIECES	Mod. ATZ/EV	ME 21

AIR SERVICE UNIT	Mod. SRA/EV	ME 21
PUSHBUTTON PANEL	Mod. PULS/EV	ME 22
SILENCED COMPRESSOR	Mod. 3409A	ME 22

### WORKING CELLS & AUTOMATED PRODUCTION LINES

AUTOMATIC PIECES IDENTIFICATION AND SELECTION CENTRE CONTROLLED BY PLC	Mod. MCS-A1/EV	ME 24
AUTOMATIC PIECES IDENTIFICATION, THICKNESS MEASUREMENT AND STORAGE LINE CONTROLLED BY PLC	Mod. MCS-B1/EV	ME 25
MULTILEVEL STORAGE SYSTEM WITH PIECES IDENTIFICATION STATION ON ROTARY INDEXING TABLE IN CLOSED LOOP MODE	Mod. MCS-C1/EV	ME 26
AUTOMATIC MULTISTATION LINE FOR SAMPLES TEST AND WORKING	Mod. MCS-D1/EV	ME 27
AUTOMATIC MULTILEVEL STORAGE FOR PRODUCT SAMPLES WORKING	Mod. MCS-E1/EV	ME 28
AUTOMATIC WEIGHTING AND SELECTION SYSTEM WITH PNEUMATIC ROBOT AND DOUBLE CONVEYOR	Mod. MCS-F1/EV	ME 29
MULTILEVEL STORAGE SYSTEM WITH PIECE TESTING STATION ON ROTARY INDEXING TABLE AND CONVEYOR MODULE IN CLOSED LOOP MODE	Mod. MCS-G1/EV	ME 30

### BASIC LINE

MANIPULATING ARM	Mod. RDIDA/EV	ME 32
TEST AND SELECTION SYSTEM WITH CONVEYOR BELT	Mod. TDIDA/EV	ME 33

## ROBOTICS

ROBOTIC WORKCELL	Mod. KUB-1/EV	RO 5
ROBOT STATION WITH ARTIFICIAL VISION SYSTEM	Mod. RV3/EV	RO 7
MOBILE ROBOT	Mod. SPUTK/EV	RO 12
LIGHT WEIGHT ROBOT	Mod. LWR/EV	RO 13

## SOFTWARE AND INTERFACES

### SOFTWARE

PLC PROGRAMMING, SIMULATION AND SUPERVISION SOFTWARE	Mod. SW7/EV	SI 5
PLC SUPERVISION SOFTWARE - ADVANCED LEVEL	Mod. SV/EV	SI 7
SCADA - SUPERVISORY CONTROL AND DATA ACQUISITION - SOFTWARE FOR PID CONTROLLERS	Mod. SV-1/EV	SI 8
DESIGN, SIMULATION AND ANIMATION SOFTWARE FOR INDUSTRIAL AUTOMATION	Mod. SW-CAI/EV	SI 9
DESIGN, SIMULATION AND ANIMATION SOFTWARE FOR THE STUDY OF PNEUMATICS AND ELECTRO-PNEUMATICS	Mod. SW-AIR/EV	SI 11
DESIGN, SIMULATION AND ANIMATION SOFTWARE FOR THE STUDY OF HYDRAULICS AND ELECTRO-HYDRAULICS	Mod. SW-HYD/EV	SI 13
DESIGN, SIMULATION AND ANIMATION SOFTWARE FOR THE STUDY OF ELECTRO-PNEUMATICS & ELECTRO OIL-HYDRAULICS	Mod. SW-FLU/EV	SI 14
DESIGN, SIMULATION AND ANIMATION SOFTWARE FOR THE STUDY OF ELECTRICAL ENGINEERING	Mod. SW-ELT/EV	SI 15
3D DESIGN AND ANIMATION SOFTWARE FOR ROBOT CELLS	Mod. 3DKUB/EV	SI 16
3D DESIGN AND ANIMATION SOFTWARE FOR ROBOT CELLS	Mod. 3DRV/EV	SI 17
VIRTUAL PROCESS SIMULATION SOFTWARE	Mod. SSP-VR/EV	SI 18

### INTERFACES

INTERFACE BOARD	Mod. C2-IO/EV	SI 20
-----------------	---------------	-------

# GENERAL INTRODUCTION

**ELETRONICA VENETA S.p.A.** has been designing and manufacturing educational equipment since 1963. This equipment, covering the different fields of technology, fulfils two important educational objectives:

- to facilitate the learning process of the student by means of real systems which illustrate practically the important aspects of the theory learned in the classroom.
- to simplify the work of the teacher enabling the demonstration of the real, practical applications of the theory learned.

Increasing the efficiency of the didactic process improves and simplifies the integration of young students into the world of employment and justifies the material and human investments made in schools throughout the world.

**ELETRONICA VENETA S.p.A.** operates on an international level and takes into consideration the training programmes and cultures of each specific country. In order to meet different requirements, we offer flexible systems which ensure maximum compliance with the latest technologies, technological advances and the professional profile requirements of local industry.

The proposed laboratories and training equipment are suitable for regular school education as well as ongoing post-diploma training courses and professional re-qualification.

Our training equipment covers most of the technological sectors included in the training programmes of vocational schools, technical institutes and universities, both national and international.

**ELETRONICA VENETA S.p.A.** headquarters is located in the green fields of the Veneto region, not far from Venice, and constitute a centre for equipment design and development suited to the training needs of all professional and technical profiles. The modern premises integrates R&D laboratories, a production plant and a fully equipped teacher training centre.

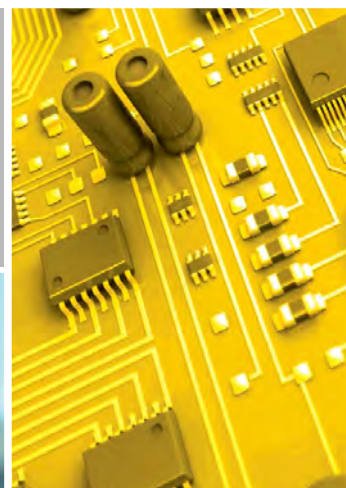

The integration of these efficient training systems into local school structures ensures high-quality, state-of-the-art training programmes which meet the diverse professional expectations of the student and the technological requirements of industry and research within their specific local contexts.

The ISO 9001 (Quality System Certification) obtained in 1998 and updated in application of the latest edition of the International Standard, is further testament to the quality-driven organisation of **ELETRONICA VENETA S.p.A.** aimed at providing top standard equipment, training and service.



# PRESENTATION

The field of industrial automation is characterized by a fast and constant technological development which also affects the educational proposal concerning these technologies.

Thanks to an experience in the education of industrial automation accruing from some decades, **ELETTRONICA VENETA S.p.A.** can propose some solutions which satisfy every educational need (for schools, universities, research, retraining and refresher courses, etc...), training program and even specific local situations in the several countries where we are present.

In fact the laboratories and equipment produced by Elettronica Veneta S.p.A. are designed, developed and carried out with characteristics of modularity, flexibility, expandability, ergonomics and easy use which enable to offer always a solution meeting the characteristics requested.

The techniques and components used by our company are wholly industrial and consistent with the technological solutions applied at present in this sector.

Our educational proposal is divided into several subjects: starting from the study of the basics of industrial automation such as pneumatics, oil-hydraulics and PLC programming, students are gradually led to deal with more complex topics such as mechatronics and robotics. For instance, mechatronics combines knowledge coming from different fields such as mechanics, electronics, pneumatics, Programmable Logic Controllers and industrial engineering which are considered in the previous sections.

Furthermore, each part of this catalogue includes preparatory equipment being suitable for the basic study of a specific topic, besides the equipment designed for advanced studies. There are also apparatuses which study specific processes and systems of particular interest (such as the simulation of iron metallurgy, or the operation of a lift), as well as software applications which enable to complete the training program of some apparatuses.

The final target consists in supplying the necessary skills for the training of engineers highly specialized in the field of automation so that they will be able to design the detailed operation of a computer-assisted production process for the manufacture and management of different types of products (FMS – Flexible Manufacturing system).



The offer of equipment produced by **ELETTRONICA VENETA S.p.A.** for Laboratories of **AUTOMATION TECHNOLOGIES** consists of seven product lines:

- **PNEUMATICS**
- **OIL-HYDRAULICS - ELECTRO OIL-HYDRAULICS - PROPORTIONAL OIL-HYDRAULICS**
- **PLC - SIMULATORS AND APPLICATIONS**
- **PROCESS CONTROLS**
- **MECHATRONICS**
- **ROBOTICS**
- **SOFTWARE AND INTERFACES**







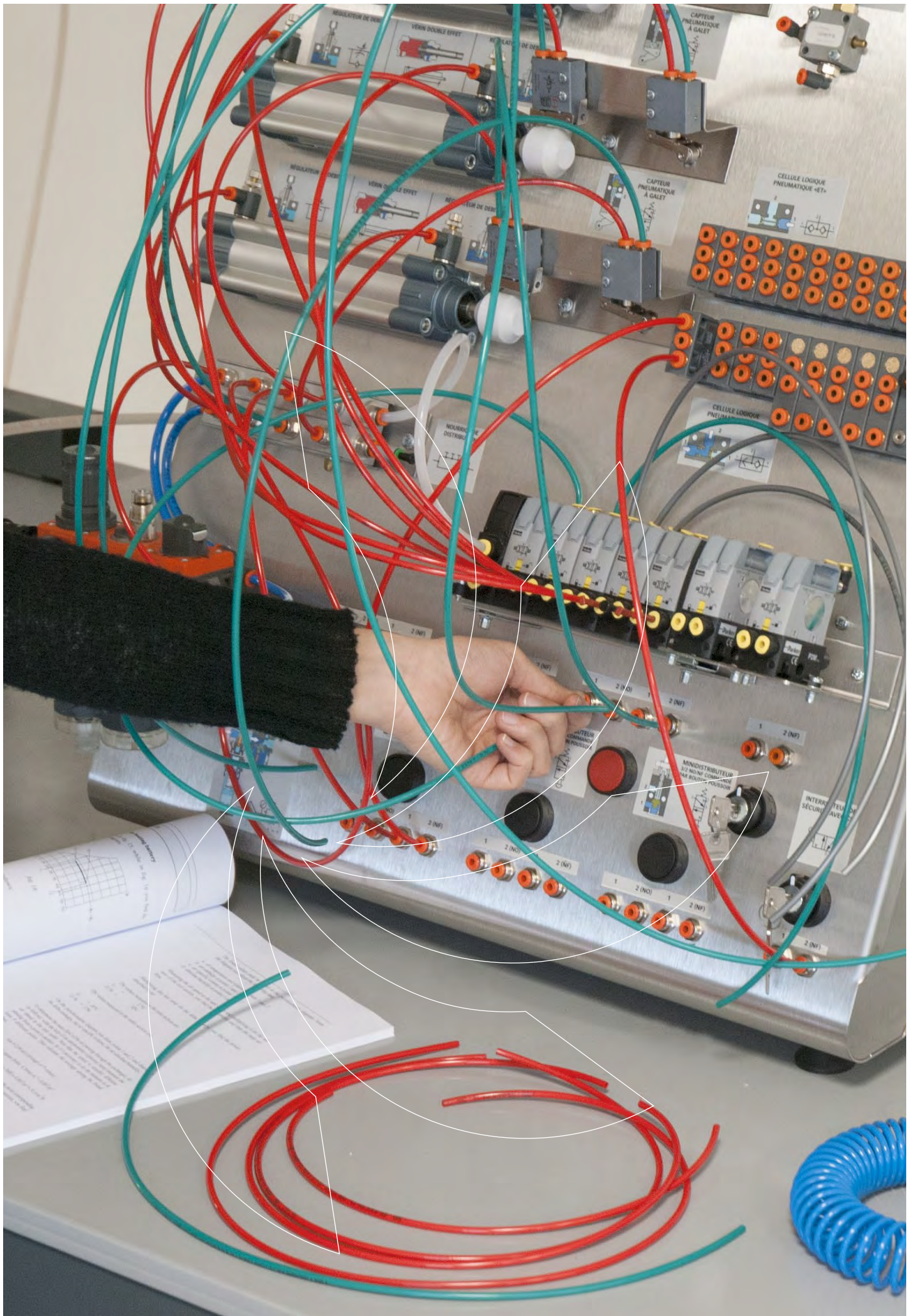



# 26-D



## PNEUMATICS

PN

www.elettronicaveneta.com

**Aim:**

- Studying the components, operational methods and programming logics of pneumatic and electro-pneumatic circuits, either at basic and advanced levels. Examining the corresponding topics, such as the study of proximity sensors, in depth.



**Equipment:**

- Trainers and kits for studying pneumatics
- Trainers and kits for studying electro-pneumatics
- Kit for studying proportional pneumatics
- Tools and accessories for developing additional activities

# 26-D



## PNEUMATICS

	<b>PNEUMATICS</b>	<b>PN4</b>
	<b>ELECTRO-PNEUMATICS</b>	<b>PN11</b>
	<b>PROPORTIONAL PNEUMATICS</b>	<b>PN21</b>

# 26-b



## PNEUMATICS

<b>BASIC PNEUMATICS TRAINER</b>	Mod. ALPE-BC/EV	PN 5
<b>ADVANCED PNEUMATICS KIT</b>	Mod. ALPE-AD/EV	PN 7
<b>PNEUMATICS STUDENT TRAINER</b>	Mod. SPT/EV	PN 8
<b>PNEUMATICS PROFESSOR TRAINER</b>	Mod. PPT/EV	PN 9
<b>PNEUMATICS CUT-AWAY COMPONENTS</b>	Mod. VCPE/EV	PN 10



# BASIC PNEUMATICS TRAINER

## Mod. ALPE-BC/EV

The Basic pneumatics trainer mod. ALPE-BC/EV has been designed to implement complete application programs on pneumatic automation.

Each trainer mod. ALPE-BC/EV can be used as a 2-place workstation on any table or work-table. A quick coupling system allows eventually to combine two trainers mod. ALPE-BC/EV, to obtain a double-face bench on which 4 students can work.



AUTOMATION TECHNOLOGIES

### TRAINING PROGRAM:

- Directional valve control
- Timed controls
- Safety controls
- Pneumatic logic
- Fundamental logic functions
- Derived logic functions
- Combinational logic controls
- Sequential logic controls

### TECHNICAL SPECIFICATIONS:

Inclined stainless steel support panel on which the supplied components are mounted. It has two lateral handles for easy transportation and includes the following elements:

#### Air service unit, consisting of:

- 1 3/2 valve for general pneumatic supply
- 1 filter with automatic discharge dehumidifier
- 1 pressure reducing valve, 0.2÷8 bar with overpressure discharge
- 1 manometer 0÷10 bar
- 1 multiple coupling for power supplies (1 x Ø 6 mm; 4 x Ø 4 mm), with non-return valves
- 1 extensible hose Ø 8 mm, 6 m length, complete with quick acting couplings, for pneumatic supply

#### Push button, lever and indicator console, consisting of:

- 2 pressure indicators, green and red
- 2 3/2 monostable flush push buttons, NC
- 1 3/2 monostable flush push button, NO
- 1 5/2 bistable lever valve
- 1 3/2 monostable lever valve, NC

#### Pneumatic actuators

1 Single-acting cylinder, Ø12 mm, l=50 mm, including:

- 1 magnetic piston
- 1 3/2 roll limit switch, NC
- 1 3/2 one-way lever limit switch, NC
- 1 unidirectional flow regulator mounted on the cylinder

1 Double-acting cylinder, Ø 20 mm, l=100 mm, including:

- 1 magnetic piston
- 1 3/2 roll limit switch, NC
- 1 3/2 one-way lever limit switch, NC

1 Double-acting cylinder, Ø 20 mm, l=100 mm, including:

- 1 magnetic piston
- 2 unidirectional flow regulators mounted on the cylinder.

#### Power valve package, including:

- 1 3/2 monostable valve with pneumatic control
- 1 5/2 monostable valve with pneumatic control
- 3 5/2 bistable valves with pneumatic control

#### Set of pneumatic components

- 1 Manometer 0÷10bar
- 2 Unidirectional line flow control valves
- 1 Quick exhaust valve
- 1 Sequence valve

26D-E-PN-ALPEBC-1 www.elettronicaveneta.com

**Pneumatic logic**

- 2 "OR" logic elements
- 2 "AND" logic elements
- 2 "NOT" logic elements
- 2 "YES" logic elements
- 1 3/2 TON Timer (NO or NC output), 0÷30s

**Dimensions:** 800 x 350 x 740 mm

**Weight:** 17 kg



*TRAINER mod. ALPE-BC/EV with the KIT mod. ALPE-AD/EV*

**REQUIRED****UTILITIES (PROVIDED BY THE CUSTOMER)**

- Compressed Air: 6 bar, 10 NI/min max. , or
- Silenced compressor reservoir capacity 9 l mod. 3409A

**OPTIONAL****SUGGESTED SOFTWARE:**

- Design, simulation and animation software for the study of pneumatics and electro-pneumatics mod. SW-AIR/EV

**OR AS AN ALTERNATIVE:**

- Design, simulation and animation software for the study of electro-pneumatics & electro oil-hydraulics mod. SW-FLU/EV, or
- Design, simulation and animation software for Industrial automation mod. SW-CAI/EV.

**SUPPLIED WITH****Accessories:**

Flexible tube Ø 4, pipe cutter, extractor, straight & T connectors, quick couplings, taps, bench supply tube with couplings.

**THEORETICAL-EXPERIMENTAL HANDBOOK  
WITH INTRODUCTION TO PRACTICAL  
EXERCISES**



# ADVANCED PNEUMATICS KIT

## Mod. ALPE-AD/EV

This Advanced pneumatics kit is supplied only as an extension to the trainer for the study of basic pneumatics mod. ALPE-BC/EV, as it shares the support panel and a number of other elements.

### TRAINING PROGRAM:

Main circuits that can be created:

- Controls with differential valves
- Speed regulation
- Controls with selector and two pressure valves
- Pressure-dependent controls
- Timed controls
- Safety controls
- Pneumatic logics
- Fundamental logic functions
- Derived logic functions
- Combinational logics controls
- Sequential logic controls
- Emergency controls
- The square cycle
- The "L" cycle
- The "U" cycle
- 3-cylinder working cycle
- The cascade technique
- The pneumatic sequencer

### TECHNICAL SPECIFICATIONS:

Easily transportable case with three drawers containing:

**Push button, lever and indicator console**, consisting of:

- 2 3/2 mono-stable flush push buttons, NC
- 1 3/2 emergency push button, mechanical latching
- 1 5/2 bistable lever valve
- 1 3/2 monostable lever valve, NC
- 1 presettable pneumatic counter

#### Pneumatic actuators

**1 Double-acting cylinder Ø 25 mm, l=100 mm** including:

- 1 magnetic piston
- 1 3/2 unidirectional roll limit switch, NC

**1 Double-acting cylinder Ø 20 mm, l=100 mm** including:

- 1 magnetic piston
- 1 pressure return limit switch
- 2 pressure drop (NOT) limit switches, mounted on the cylinder

#### Power valve package, including

- 4 3/2 monostable valves with pneumatic control
- 2 5/2 bistable valves with pneumatic control
- 2 exhaust silencers

#### Pneumatic logics

- 4 logic elements OR
- 3 logic elements AND
- 4 logic elements NOT



#### Set of pneumatic components

- 1 pneumatic sequencer consisting of 4 memory phases
- 2 Unidirectional in line flow control valves
- 2 non-return valves
- 1 3/2 TON Timer (NO or NC output), 0÷30s

**Dimensions:** 400 x 320 x 400 mm

**Weight:** 10 kg

### REQUIRED

#### UTILITIES (PROVIDED BY THE CUSTOMER)

- Compressed Air: 6 bar, 10 NI/min max. , or
- Silenced compressor reservoir capacity 9 l mod. 3409A

### OPTIONAL

#### SUGGESTED SOFTWARE:

- Design, simulation and animation software for the study of pneumatics and electro-pneumatics mod. SW-AIR/EV

#### OR AS AN ALTERNATIVE:

- Design, simulation and animation software for the study of electro-pneumatics & electro oil-hydraulics mod. SW-FLU/EV, or
- Design, simulation and animation software for Industrial automation mod. SW-CAI/EV.

### SUPPLIED WITH

#### Accessories:

Flexible tube Ø 4, pipe cutter, extractor, straight & T connectors, quick couplings, valve caps., bench supply tube with coupling.

#### THEORETICAL-EXPERIMENTAL HANDBOOK WITH INTRODUCTION TO PRACTICAL EXERCISES





# PNEUMATICS STUDENT TRAINER

## Mod. SPT/EV

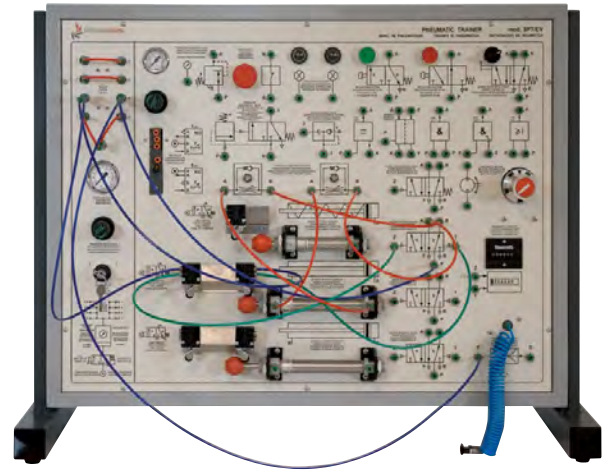

The equipment enables the student to develop a training course in pneumatic control techniques and pneumatic logic. It is a flexible support for the execution and demonstration of pneumatic circuits and enables to build up several industrial sequential cycles by using various standard procedures.

The vertical silk screen printed plate constituting the core of the equipment reports the standard symbols of the provided pneumatic components, fitted on the rear part of the plate. The teacher can connect the components between them, analyze and demonstrate immediately the studied pneumatic circuit using flexible hoses and quick acting couplings.

### TRAINING PROGRAM:

Main circuits:

- Controls with directional valves
- Speed regulation
- Controls by shuttle and 2-pressure valves
- Controls depending on pressure
- Timing controls
- Safety controls
- Pneumatic logic
- Elementary logic functions
- Advanced logic functions
- Combined logic controls
- Memories
- Sequential logic controls
- Emergency controls
- Square cycle
- "L" cycle
- "U" cycle
- Cascade technique

### TECHNICAL SPECIFICATIONS:

- Industrial pneumatic components
- Connections with flexible hoses and quick acting couplings
- Standard symbols

**Provided pneumatic components:**

- 1 3/2 main switch
- 1 pressure regulator valve
- 2 pressure gauge
- 1 multiple coupling for power supplies (8 x Ø = 4 mm)
- 1 pressure reducing valve
- 1 self blocking red pushbutton
- 2 pressure display
- 1 3/2-way valve with pushbutton actuator NC
- 1 3/2 way valve with pushbutton actuator NO
- 1 5/2-way valve with selector actuator

- 1 timer with function TON
- 1 pressure sequence valve
- 1 quick exhaust valve
- 1 logic element YES
- 1 memories
- 1 logic element AND
- 1 logic element NOT
- 1 logic element OR
- 2 one-way flow control valve
- 1 cylinder simple effect
- 2 cylinders double effect
- 5 3/2-way limit switches
- 3 5/2-way valve bistable
- 1 5/2-way valve monostable
- 1 pneumatic motor
- 1 pneumatic counter
- 1 vacuum generator

**Dimensions:** 900 x 710 x 450 mm

**Weight:** 30 kg

### REQUIRED

#### UTILITIES (PROVIDED BY THE CUSTOMER)

- Compressed Air: 6 bar, 30 NI/min max. , or
- Silenced compressor reservoir capacity 9 l mod. 3409A

### OPTIONAL

#### SUGGESTED SOFTWARE:

- Design, simulation and animation software for the study of pneumatics and electro-pneumatics mod. SW-AIR/EV

#### OR AS AN ALTERNATIVE:

- Design, simulation and animation software for the study of electro-pneumatics & electro oil-hydraulics mod. SW-FLU/EV, or
- Design, simulation and animation software for industrial automation mod. SW-CAI/EV.

### SUPPLIED WITH

#### Accessories:

Flexible hose Ø 4 mm, hose cutter, extractor, joints, quick acting coupling, bench supply hose with couplings.

#### THEORETICAL-EXPERIMENTAL HANDBOOK WITH INTRODUCTION TO PRACTICAL EXERCISES



# PNEUMATICS PROFESSOR TRAINER

## Mod. PPT/EV



The equipment enables the teacher to develop a training course in pneumatic control techniques and pneumatic logic. It is a flexible support for the execution and demonstration of pneumatic circuits and enables to build up several industrial sequential cycles by using various standard procedures.

The vertical silk screen printed plate constituting the core of the equipment reports the standard symbols of the provided pneumatic components, fitted on the rear part of the plate.

The Teacher can connect the components between them, analyze and demonstrate immediately the studied pneumatic circuit using flexible hoses and quick acting couplings.

### TRAINING PROGRAM:

Main circuits:

- Controls with directional valves
- Speed regulation
- Controls by shuttle and 2-pressure valves
- Controls depending on pressure
- Timing controls
- Safety controls
- Pneumatic logic
- Elementary logic functions
- Advanced logic functions
- Combined logic controls
- Memories
- Sequential logic controls
- Emergency controls
- Square cycle
- "L" cycle
- "U" cycle
- 3-cylinder operating cycle
- Cascade technique
- Pneumatic sequencer

### TECHNICAL SPECIFICATIONS:

- Industrial pneumatic components
- Connections with flexible hoses and quick acting couplings
- Colored standard symbols
- Fully mobile

**Provided pneumatic components:**

- 1 separator filter
- 2 pressure reducing valves
- 2 pressure gauges
- 1 3/2 main switch
- 4 3/2 pushbuttons
- 2 3/2 lever valves

- 6 pressure indicators
- 4 5/2 valves
- 4 cylinders
- 12 3/2 limit switches
- 8 exhaust regulators
- 2 one-way throttle valves
- 2 time delay valves
- 6 memories
- 8 NOT elements
- 2 YES elements
- 6 OR elements
- 8 AND elements

**Dimensions:** 1700 x 700 x 1700 mm

**Weight:** 113 kg

### REQUIRED

#### UTILITIES (PROVIDED BY THE CUSTOMER)

- Compressed Air: 6 bar, 30 NI/min max. , or
- Silenced compressor reservoir capacity 9 l mod. 3409A

### OPTIONAL

#### SUGGESTED SOFTWARE:

- Design, simulation and animation software for the study of pneumatics and electro-pneumatics mod. SW-AIR/EV

#### OR AS AN ALTERNATIVE:

- Design, simulation and animation software for the study of electro-pneumatics & electro oil-hydraulics mod. SW-FLU/EV, or
- Design, simulation and animation software for industrial automation mod. SW-CAI/EV.

### SUPPLIED WITH

#### Accessories:

Flexible hose Ø 4 mm, hose cutter, extractor, joints, quick acting couplings, taps, bench supply hose with couplings.

#### THEORETICAL-EXPERIMENTAL HANDBOOK WITH INTRODUCTION TO PRACTICAL EXERCISES



# PNEUMATICS CUT-AWAY COMPONENTS

## Mod. VCPE/EV

The pneumatics cut-away components have been carefully selected among all the industrial components produced all over the world in order to enable students to analyze a wide range of technical features.

The main characteristics of pneumatic cut-away components are the following:

- Industrial cut-away components
- Several sizes
- Several operating principles
- Various constructional techniques

### TRAINING PROGRAM:

- Functional analysis of each component

### TECHNICAL SPECIFICATIONS:

The set includes a case with the following components:

1. 3/2 monostable pushbutton
2. One-way flow control valve
3. TON timer ( delay)
4. 5/2 roller-lever, piloted limit switch
5. 3/2 roller-lever, piloted limit switch
6. Double-acting cylinder
7. Single-acting cylinder
8. 3/2 limit switch with lever
9. Quick exhaust valve
10. Shuttle valve
11. 5/2 monostable pushbutton

**Dimensions:** 515 x 425 x 135 mm

**Weight:** 6 kg



### OPTIONAL

#### SUGGESTED SOFTWARE:

- Design, simulation and animation software for the study of pneumatics and electro-pneumatics mod. SW-AIR/EV

#### OR AS AN ALTERNATIVE:

- Design, simulation and animation software for the study of electro-pneumatics & electro oil-hydraulics mod. SW-FLU/EV, or
- Design, simulation and animation software for industrial automation mod. SW-CAI/EV.

### SUPPLIED WITH

**THEORETICAL-EXPERIMENTAL  
HANDBOOK**







# ELECTRO-PNEUMATICS

<b>BASIC ELECTRO-PNEUMATICS TRAINER</b>	Mod. ALEP-BC/EV	PN 12
<b>ADVANCED ELECTRO-PNEUMATICS KIT</b>	Mod. ALEP-AD/EV	PN 13
<b>BASIC ELECTRO-PNEUMATICS KIT</b>	Mod. KALEP/EV	PN 14
<b>ELECTRO-PNEUMATIC ACTUATORS TRAINER</b>	Mod. EAT/EV	PN 15
<b>SET OF POSTERS ON PNEUMATICS AND ELECTRO-PNEUMATICS</b>	Mod. POS-PE/EV	PN 16
<b>PROXIMITY SENSORS TRAINER</b>	Mod. ALP-PSX/EV	PN 17
<b>ARTIFICIAL COLOUR VISION SYSTEM</b>	Mod. AVS-1/EV	PN 19

# BASIC ELECTRO-PNEUMATICS TRAINER

## Mod. ALEP-BC/EV



The Basic electro-pneumatics trainer mod. ALEP-BC/EV has been designed to implement complete application programs on pneumatics automation.

Each trainer can be used as a 2-place workstation on any table or work-table. A quick coupling system allows eventually to combine two trainers mod. ALEP-BC/EV, by obtaining a doubleface bench on which 4 students can work.

### TRAINING PROGRAM:

- Semi-automatic controls
- Automatic controls
- 3/2 and 5/2 electrovalves operation and applications
- Proximity sensors
- Fundamental logic functions
- Trouble-shooting on simple electro-pneumatics circuits

### TECHNICAL SPECIFICATIONS:

Inclined support, it is composed by a stainless steel support panel, where the supplied components are mounted. It has two lateral handles for an easy transportation in the Lab, and it includes the following elements:

**Air treatment group**, composed by:

- 1 3/2 valve for general pneumatic supply
- 1 filter with automatic discharge dehumidifier
- 1 pressure reducing valve, 0.2÷8 bar with overpres. discharge
- 1 manometer 0÷10 bar
- 1 multiple couplings for power supplies (1 x Ø 6; 4 x Ø 4), with non-return valves
- 1 extensible hose Ø 8 mm, 6 m length, complete with quick acting couplings, for pneumatic supply

#### Pneumatic actuators

1 Single-acting cylinder, Ø12 mm, l=50 mm, including:

- 1 magnetic piston
- 1 unidirectional flow regulator mounted on the cylinder

1 Double-acting cylinder, Ø 20 mm, l=100 mm, including:

- 1 magnetic piston
  - 2 unidirectional flow regulator mounted on the cylinder
- 1 Double-acting cylinder, Ø 20 mm, l=100 mm, including:
- 1 magnetic piston
  - 2 unidirectional flow regulator mounted on the cylinder.

**Low voltage control console composed by:**

- 24 Vdc 2A power supply unit
- 6 4 C/O relays (2 NO + 2 NC)
- 6 pilot lamps 24 Vdc
- 2 mono-stable push buttons
- 2 self-latching push buttons

- 1 self-locking emergency push button (1NO + 1 NC)
- 4 quick couplings for limit switch (1 cont. NO + 1 cont. NC)
- 4 quick couplings for electrovalves feeding

#### Sensors and limit switches

- 1 electric limit switch, left-actuated
- 1 electric limit switch, right-actuated
- 1 optical proximity sensor
- 2 LED magnetic sensors to be fixed on the cylinders
- 1 pressure sensor with display (analog and digital output)

#### Electrovalves group

- 2 3/2 mono-stable electrovalves with LED NC
- 1 5/2 mono-stable electrovalve with LED
- 2 5/2 bi-stable electrovalves with LED

**Power supply:** 230 Vac 50 Hz single-phase - 100 VA  
(Other voltage and frequency on request)

**Dimensions:** 600 x 350 x 750 mm

**Weight:** 17 kg

### REQUIRED

#### UTILITIES (PROVIDED BY THE CUSTOMER)

- Compressed Air: 6 bar, 50 NI/min max. , or
- Silenced compressor reservoir capacity 9 l mod. 3409A

### OPTIONAL

#### SUGGESTED SOFTWARE:

- Design, simulation and animation software for the study of pneumatics and electro-pneumatics mod. SW-AIR/EV

#### OR AS AN ALTERNATIVE:

- Design, simulation and animation software for the study of electro-pneumatics & electro oil-hydraulics mod. SW-FLU/EV, or
- Design, simulation and animation software for industrial automation mod. SW-CAI/EV.

#### I/O INTERFACE

- Interface board mod. C2-IO/EV

#### SUGGESTED PLC

Intelligent logic module Mod. ILM-V1/EV

### SUPPLIED WITH

#### Accessories:

Flexible tube Ø 4, pipe cutter, extractor, straight & T connections, quick couplings.

#### THEORETICAL-EXPERIMENTAL HANDBOOK WITH INTRODUCTION TO PRACTICAL EXERCISES



# ADVANCED ELECTRO-PNEUMATICS KIT

## Mod. ALEP-AD/EV



This advanced pneumatics kit is supplied only as an extension to the trainer for the study of basic pneumatics mod. ALEP-BC/EV, as it shares the support panel and a number of other elements.

### TRAINING PROGRAM:

- Semi-automatic controls
- Automatic controls
- Emergency controls
- 3/2 and 5/2 electrovalve operation and applications
- Proximity sensors
- Fundamental logic functions
- Troubleshooting simple electro-pneumatic circuits

### TECHNICAL SPECIFICATIONS:

**Low voltage electrical control console**, consisting of:

- 3 4-C/O relays (2 NO + 2NC)
- 3 pilot lamps 24 VDC
- 2 monostable push buttons
- 2 self latching push buttons
- 1 electric self-locking emergency push button
- 1 presettable electronic pulse counter
- 2 electronic timers (TON + TOFF)

#### Sensors

- 1 inductive proximity sensor
- 1 capacitive proximity sensor

#### Electro-valve group

- 1 4-electrovalve terminal:
  - 2 monostable 5/2 electro-valves
  - 2 bistable 5/2 electro-valves

#### Pneumatic elements

- 2 Pilot-operated one-way flow control valves

**Power supply:** 230 Vac 50 Hz single-phase - 100 VA  
(Other voltage and frequency on request)

**Dimensions:** 400 x 320 x 400 mm

**Weight:** 9 kg

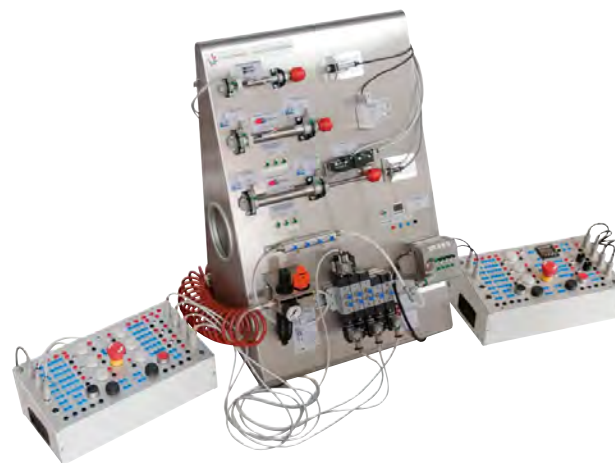

TRAINER mod. ALEP-BC/EV with KIT mod. ALEP-AD/EV

### REQUIRED

#### UTILITIES (PROVIDED BY THE CUSTOMER)

- Compressed Air: 6 bar, 50 NI/min max. , or
- Silenced compressor reservoir capacity 9 l mod. 3409A

### OPTIONAL

#### SUGGESTED SOFTWARE:

- Design, simulation and animation software for the study of pneumatics and electro-pneumatics mod. SW-AIR/EV

#### OR AS AN ALTERNATIVE:

- Design, simulation and animation software for the study of electro-pneumatics & electro oil-hydraulics mod. SW-FLU/EV, or
- Design, simulation and animation software for industrial automation mod. SW-CAI/EV.

#### I/O INTERFACE

- Interface board mod. C2-IO/EV

#### SUGGESTED PLC

Intelligent logic module Mod. ILM-V1/EV

### SUPPLIED WITH

#### Accessories:

Flexible tube Ø 4, pipe cutter, extractor, straight a T connectors, quick couplings.

#### THEORETICAL-EXPERIMENTAL HANDBOOK WITH INTRODUCTION TO PRACTICAL EXERCISES



# BASIC ELECTRO-PNEUMATICS KIT Mod. KALEP/EV

This kit has been expressly designed for the complete development of application programs in the field of electro-pneumatics automation.

This kit for the study of basic electro-pneumatics is supplied as an extension to the trainer for the study of basic pneumatics mod. ALPE-BC/EV as it shares the support panel and a number of other elements.

## TRAINING PROGRAM:

- Semi-automatic controls
- Automatic controls
- 3/2 and 5/2 electrovalve operation and applications
- Proximity sensors
- Fundamental logic functions
- Troubleshooting simple electro-pneumatic circuits

## TECHNICAL SPECIFICATIONS:

### Electrovalve Group

- 2 3/2 monostable electrovalves with LED, NC
- 1 5/2 monostable electrovalve with LED
- 2 5/2 bistable electrovalves with LED

### Sensors and limit switches

- 1 Electric limit switch, left actuated
- 1 Electric limit switch, right actuated
- 1 Retro-reflective proximity sensor
- 2 Magnetic sensors with LED for mounting on the cylinders
- 1 Pressure sensor with display (analog and digital output)

### Low voltage electrical control console

- Power supply 24 VDC 2 A
- 6 4-C/O relays (2 NO + 2 NC)
- 6 Pilot lamps 24 VDC
- 2 monostable push buttons
- 2 Latching push buttons
- 1 self-locking mushroom push button (1 NO + 1 NC)
- 4 Quick couplings for limit switches (1 NO contact + 1 NC contact)
- 4 Quick couplings for supplies and electrovalves

**Power supply:** 230 Vac 50 Hz single-phase - 100 VA  
(Other voltage and frequency on request)

**Dimensions:** 400 x 320 x 400 mm

**Weight:** 7 kg



## REQUIRED

### UTILITIES (PROVIDED BY THE CUSTOMER)

- Compressed Air: 6 bar, 50 NI/min max. , or
- Silenced compressor reservoir capacity 9 l mod. 3409A

## OPTIONAL

### SUGGESTED SOFTWARE:

- Design, simulation and animation software for the study of pneumatics and electro-pneumatics mod. SW-AIR/EV

### OR AS AN ALTERNATIVE:

- Design, simulation and animation software for the study of electro-pneumatics & electro oil-hydraulics mod. SW-FLU/EV, or
- Design, simulation and animation software for industrial automation mod. SW-CAI/EV.

### I/O INTERFACE

- Interface board mod. C2-IO/EV

### SUGGESTED PLC

Intelligent logic module Mod. ILM-V1/EV

## SUPPLIED WITH

### Accessories:

Flexible tube Ø 4, pipe cutter, extractor, straight & T connections, quick couplings.

**THEORETICAL-EXPERIMENTAL HANDBOOK  
WITH INTRODUCTION TO PRACTICAL  
EXERCISES**





# ELECTRO-PNEUMATIC ACTUATORS TRAINER

## Mod. EAT/EV

This system includes the most modern types of pneumatic actuators, electropneumatic valves and position sensors. It allows the development of a wide electropneumatic program and is suggested as application system for sequential programs developed with Programmable Logic Controllers (PLC).

The main characteristics of the system are the following:

- Protection with E.L.C.B.
- 24-Vdc stabilized power supply
- Compressed air conditioning unit
- Low voltage electrical control board
- Industrial components
- Standard symbols
- Fully mobile

### TRAINING PROGRAM:

- Boolean functions
- Manual controls
- Semiautomatic and automatic controls
- Emergency controls
- Sequential cycles
- Development of sequential cycles of different complexity, with the help of programmable logic controllers PLC

### TECHNICAL SPECIFICATIONS:

- Rodless double-acting cylinder, controlled with two 3/2 single solenoid valves, including direct reflection photoelectric position transducer with analog output
- Oscillating pneumatic motor with 5/2 double-solenoid valve and 2 electrical limit switches with pressure drop
- Bidirectional DC electrical motor, with optoelectronic transducer
- Single-acting cylinder with 3/2 single solenoid valve, capacitive and magnetic proximity limit switch
- Rod double-acting cylinder, with 5/3 closed-center solenoid valve, double-solenoid, complete with 4 limit switches: electromechanical, inductive proximity, optical reflection type, light barrier optical fiber
- Electrical board with pushbuttons and relays
- Electrical cables of different lengths

**Power supply:** 230 Vac 50 Hz single-phase - 100 VA  
(Other voltage and frequency on request)

**Dimensions:** 1000 x 700 x 1700 mm

**Weight:** 85 kg



### REQUIRED

#### UTILITIES (PROVIDED BY THE CUSTOMER)

- Compressed Air: 6 bar, 50 NI/min max, or
- Silenced compressor reservoir capacity 9 l mod. 3409A

### OPTIONAL

#### SUGGESTED SOFTWARE:

- Design, simulation and animation software for the study of pneumatics and electro-pneumatics mod. SW-AIR/EV

#### OR AS AN ALTERNATIVE:

- Design, simulation and animation software for the study of electro-pneumatics & electro oil-hydraulics mod. SW-FLU/EV,
- Design, simulation and animation software for Industrial automation mod. SW-CAI/EV.

#### I/O INTERFACE

Interface board mod. C2-IO/EV

#### SUGGESTED PLC:

Intelligent logic module Mod. ILM-V1/EV

### SUPPLIED WITH

**THEORETICAL-EXPERIMENTAL MANUAL WITH INTRODUCTION TO PRACTICAL EXERCISES**



# SET OF POSTERS ON PNEUMATICS AND ELECTRO-PNEUMATICS

## Mod. POS-PE/EV

This set of posters consists of three colour posters concerning the study of pneumatics and electro-pneumatics.

Their optimum arrangement is in the automation laboratory of any school: thus this educational material is easily available for students who can be assisted in the study and development of classes.

The first poster displays the table of symbols divided into the following groups:

- Pneumatic symbols
- Electrical symbols
- Logical symbols

The second poster will show the basic components for assembling a pneumatic circuit. The elements represented in the poster are:

- Filter unit
- 5/2-way monostable valve
- Actuators: cylinders, pliers, rotary actuators
- Logic elements: AND, OR
- Pneumatic buttons: 2/2 and 3/2
- Mechanical lever sensors, electrical Reed sensors and pressure sensors
- Flow regulators.

The third poster will show the cutaway view of the components. The cut-away elements are:

- Filter separator
- Pressure regulator
- Pressure indicator
- Unidirectional flow controller
- Silencer
- 5/2-way and 5/3-way valves
- Single-acting cylinder
- Double-acting cylinder
- Unidirectional motor.

These posters can easily be hung in the laboratory.

**Dimensions:** 1000 x 700 x 3 mm  
**Weight:** 0.5 kg

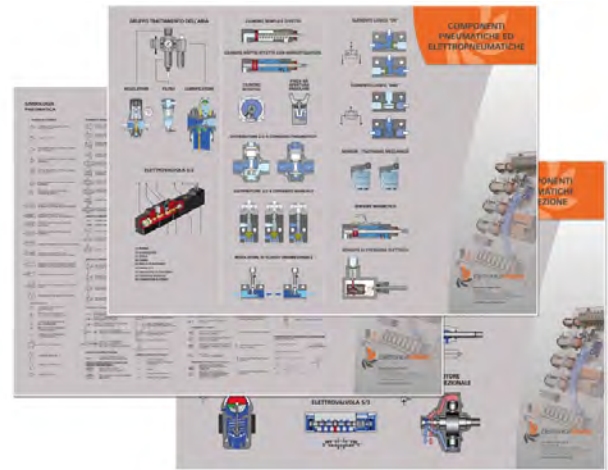

# PROXIMITY SENSORS TRAINER

## Mod. ALP-PSX/EV

The Trainer mod. ALP-PSX/EV has been conceived for the study of proximity sensors in the industrial automation field. The supplied sensors are the most commonly used in the industry. Its main objective is to give the student the means to be able to decide the type of sensor that is more suitable according to the application and according to the piece to be identified.

The sensors included in the Trainer mod. ALP-PSX/EV are the following:

- Magnetic proximity sensor (ON/OFF type)
- Inductive proximity sensor (ON/OFF type)
- Inductive proximity sensor (analog type)
- Optical proximity sensor (ON/OFF type)
- Capacitive proximity sensor (ON/OFF type)

The sensors are positioned on a base plate developed for their fixing. It is possible to develop practical experiences on the distance sensibility of the sensors according to the piece to be detected, on recognition capability according to the type of material of the piece and/or its shape and surface.

A low voltage control electric box allows powering the sensors and testing their activation by means of pilot lamps and a buzzer.



### TRAINING PROGRAM:

- Operation principles of the sensors
- Application fields of the sensors
- Influence of the type of material when choosing a sensor
- Influence of the type of surface when choosing a sensor
- Influence of the color of the piece when choosing a sensor
- Influence of the thickness of the piece when choosing a sensor
- Selection of the sensor according to the application

### TECHNICAL SPECIFICATIONS:

#### Sensors on board the plate:

1 Module with magnetic proximity sensor

- Voltage supply: 24 Vdc
- Output: NC
- Safety terminals:  $\varnothing = 4$  mm

1 Module with ON/OFF inductive proximity sensor

- Sensor dimensions: M12
- Voltage supply: 24 Vdc
- Activation distance (Sn): 4 mm
- Output: PNP
- Activation Led ON
- Safety terminals:  $\varnothing = 4$  mm
- Protections: short-circuit, polarity inversion and overload

1 Module with ON/OFF inductive proximity sensor

- Sensor dimensions: M18
- Voltage supply: 24 Vdc
- Activation distance (Sn): 8 mm
- Output: PNP
- Activation Led ON
- Safety terminals:  $\varnothing = 4$  mm
- Protections: short-circuit, polarity inversion and overload

1 Module with analog inductive proximity sensor

- Sensor dimensions: M12
- Voltage supply: 24 Vdc
- Activation distance (Sn):  $0 \div 6$  mm
- Output:  $1 \div 10$  V
- Safety terminals:  $\varnothing = 4$  mm

1 Module with optical barrier sensor - Transmitter

- Sensor dimensions: 10 x 30 x 20 mm
- Voltage supply: 24 Vdc
- Activation distance (Sn): 15 m
- Output: PNP
- Safety terminals:  $\varnothing = 4$  mm

1 Module with optical barrier sensor - Receiver

- Sensor dimensions: 10 x 30 x 20 mm
- Voltage supply: 24 Vdc
- Activation distance (Sn): 15 m
- Output: PNP -NO/NC
- Safety terminals:  $\varnothing = 4$  mm

1 Module with fiber optics sensor complete with amplifier and fiber

- Sensor dimensions: 13 x 30 x 60 mm
- Voltage supply: 24 Vdc
- Activation distance (Sn):
  - 80 mm in diffusion mode
  - 200 mm in through beam mode
- Output: NPN and PNP
- Safety terminals:  $\varnothing = 4$  mm

1 Module with optical reflection sensor complete with retro reflector.

- Sensor dimensions: 10 x 30 x 20 mm
- Voltage supply: 24 Vdc
- Activation distance (Sn): 6 m
- Output: PNP –NO/NC
- Safety terminals:  $\varnothing = 4$  mm

1 Module with optical BGS diffusion sensor

- Sensor dimensions: 10 x 30 x 20 mm
- Voltage supply: 24 Vdc
- Activation distance (Sn): 150 mm
- Output: PNP or NPN
- Safety terminals:  $\varnothing = 4$  mm
- Protections: short-circuit, polarity inversion and overload.

1 Module capacitive proximity sensor

- Sensor dimensions: M12
- Voltage supply: 24 Vdc
- Activation distance (Sn): 8 mm
- Output: automatic identification of NPN or PNP load
- Safety terminals:  $\varnothing = 4$  mm
- Protections: short-circuit, polarity inversion and overload

#### Low voltage control electric Box

Front panel, in isolating material, with synoptic silk-screened diagram of the components.

It contains:

- Power supply 24 Vdc – 2.5 A

#### Available resources

- 2 exchange relays connected to  $\varnothing = 4$  mm safety terminals
- 8 24 Vdc lamps connected to  $\varnothing = 4$  mm safety terminals
- 1 24 Vdc buzzer connected to  $\varnothing = 4$  mm safety terminals
- Safety terminals  $\varnothing = 4$  mm

#### Set of samples

It includes a set of different samples by type of material and color, to be used with the sensors.

**Power supply:** 230 Vac 50 Hz single-phase  
(Other voltage and frequency on request)

**Dimensions:** 700 x 430 x 120 mm

**Weight:** 10 kg

#### REQUIRED

INSTRUMENTS - NOT INCLUDED -  
- DIGITAL MULTIMETER

#### OPTIONAL

SUGGESTED PLC:  
Intelligent logic module Mod. ILM-V1/EV

#### SUPPLIED WITH

THEORETICAL-EXPERIMENTAL HANDBOOK  
WITH INTRODUCTION TO PRACTICAL  
EXERCISES





# ARTIFICIAL COLOUR VISION SYSTEM

## Mod. AVS-1/EV

System mod. AVS-1/EV, included in a laboratory of automation technologies, represents the necessary instrument for the training of engineers working in the industrial sectors of plant maintenance and of design. Wholly assembled with industrial components, this Trainer enables to develop a sound testing with high-level knowledge in the field of the artificial vision applied to industrial processes

The vision system installed in this equipment is one of the most powerful and common tool in industrial field. It is provided with digital inputs and outputs accessible onto jacks with  $\varnothing = 2$  mm available on the rear box. Furthermore it is possible to connect an external remote control unit including a simulator for the digital inputs and the trigger, and also some LEDs for displaying the state of the digital outputs.

The Personal Computer and the artificial vision system mod. AVS-1/EV are connected via the ethernet interface cable of the equipment. Moreover the system is configured for the connection with industrial networks such as Profinet. Turning the fastening nuts of the equipment enables this vision system to slide along the slots of the aluminium extruded profiles, so that it can approach the pieces under examination, or move away from them. Finally the technical experimental handbook provided with the Trainer will guide the students efficaciously in the implementation of the exercises.

### TRAINING PROGRAM:

This equipment enables to carry out a lot of educational applications covering the following subjects:

- Images: illumination, contrast
- Processing the images: processing typologies, processing algorithms
- Edge enhancement processes
- Detection of a machined piece
- Comparison with predefined models and standards
- Checking shapes, distances, angles, surface characteristics
- Defining the areas which must be checked in images: windows, lines, circles, ringlets
- Quality control of the machined pieces according to the data collected by the vision system.

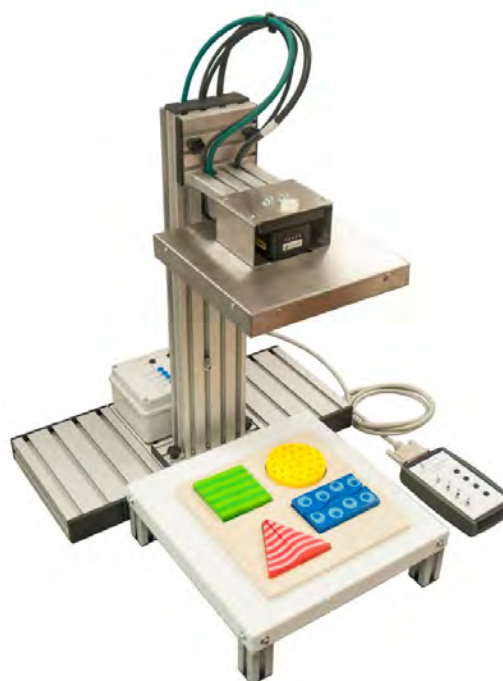

### TECHNICAL SPECIFICATIONS:

- Framework of aluminium extruded profiles
- Power supply unit of 24 Vdc/2 A, provided with electronic protection against overloads and short circuits
- External illuminator with LED matrix of 4500K
- Set of samples of different shapes (triangle, square, rectangle and circle), colours (green, red, yellow and blue) and backgrounds (waves, stripes, polka dots and bubbles)
- Raised supporting plane with white top
- 3 digital inputs
- 1 Trigger input
- 4 digital outputs of 24 Vdc
- Spirit level
- External control unit equipped with:
  - Simulator for digital inputs and Trigger signal with switches of permanent and pulsed state
  - LEDs indicating the state of digital outputs
- Standard safety jacks ( $\varnothing = 2$  mm) for connecting inputs and outputs with external devices.

### Characteristics of vision device

- Working store/program: 512 MB non volatile flash memory.
- Image processing store: 256 MB SDRAM
- Type of sensor: 1/1.8" CMOS
- Properties of this sensor: diagonal 5.3 mm, 5.3 x 5.3  $\mu\text{m}^2$  pixels
- Resolution: 800 x 600 pixels
- Shutter speed: 16  $\mu\text{s}$   $\rightarrow$  950 ms
- Bit resolution: 24-bit colour
- Focus: Autofocus
- Frames/second: 50 frames/second
- Trigger: one, opto-isolated trigger acquired from an input. Remote control by software via Ethernet.
- Digital inputs: three of 24 Vdc
- Digital outputs: four of 24 Vdc 0.5 A
- State LEDs: for networking, activity, power supply, and two LEDs which can be configured by the user
- Communication: Ethernet Port, 10/100 BaseT with auto MDI/MDIX. TCP/IP protocol IEE 802.3.

**Power supply:** 230 Vac 50 Hz single-phase  
(Other voltage and frequency on request)

**Dimensions:** 520 x 560 x 600 mm

**Weight:** 3 kg

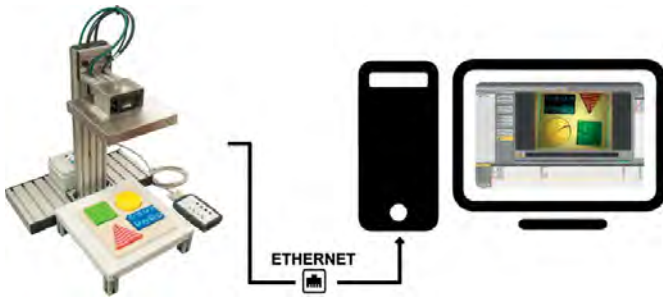

*Programming and monitoring system mod. AVS/EV by the included software via TCP/IP protocol*

### OPTIONAL

- PLC Training panel Mod. PLC-V8/EV
- PLC Training panel Mod. PLC-V7/EV

### SUPPLIED WITH

#### SOFTWARE

Powerful programming and supervisory control software.

#### THEORETICAL-APPLICATION HANDBOOK WITH GUIDE TO THE PROCESS CONTROL APPLICATIONS

#### INSTALLATION, USE AND MAINTENANCE HANDBOOK



# 26-D



## PROPORTIONAL PNEUMATICS

<b>SINGLE-LOOP PID DIGITAL CONTROLLER</b>	Mod. SLC/EV	PN 22
<b>PROPORTIONAL ELECTRO-PNEUMATICS KIT - LINEAR POSITION CONTROL</b>	Mod. ALP-PROL/EV	PN 23
<b>ELECTRO-PNEUMATICS KIT - SPEED CONTROL OF A PNEUMATIC MOTOR</b>	Mod. ALP-PROV/EV	PN 24
<b>ELECTRO-PNEUMATICS KIT - FLOW CONTROL IN A PNEUMATIC LINE</b>	Mod. ALP-PROF/EV	PN 25

# SINGLE-LOOP PID DIGITAL CONTROLLER Mod. SLC/EV

The single-loop controller for process control mod. SLC/EV is based on a high performance microcontroller in order to optimize the closed loop control of the system. The programming of the process control is carried out locally from the keyboard present on the control unit. The main function of the controller is to continuously control and monitor the process according to the programmed algorithm. The controller has the "auto-tuning" function. The programming of the characteristic parameters for P proportional, D derivative and I integrative is made by means of the pushbuttons present on the unit.

A display provides the visualization of the variables during the regulation (Set-point, process variable, etc).

## TRAINING PROGRAM:

The equipment covers the following main subjects:

- Analysis of the structure of a digital process controller
- Programming of the controller functions
- Analysis of the regulation parameters: proportional, derivative and integrative coefficient
- Algorithms applied to the functional programming of a control

## TECHNICAL SPECIFICATIONS:

### Microcontroller PID regulation section

- 50 ms size sampling
- 1 On-Off or PID loop with overshoot single or double action control
- Discontinuous/continuous regulation output
- Auto/MAN station
- Up to 4 configurable alarms
- Remote set-point
- 1 Set point programmed up to 16 segments
- Customized data view
- Auto-tuning function

### Analog inputs

- 1 analog input
- Voltage range: 0..10 V; -10 V...+10 V

### Digital inputs

- 3 optoinsulated auxiliary inputs (0-24 Vdc)

### Set Point

- Local setting by means of potentiometer
- Remote Set Point in voltage/current  
Voltage range: 0..10 V; -10 V...+10 V



### Analog Output

- 1 analog output in voltage/current  
Voltage range: 0..10 V; -10 V...+10 V

### Available power supplies

- 2 power supplies available for connection to external devices: 24 Vdc – 2 A, 10 Vdc – 0.5 A

### Digital Output

- 4 digital outputs (0-24 Vdc)

### Communication

- 1 Interface RS-485 for supervision and parametrization functions
- Cable for supervision and parametrization of the controller from PC

### Programming keyboard and display

- LCD display
- Organization with page menu
- Real-time visualization of the variables
- Alarms control
- Possibility of protection password insertion

**Power supply:** 230 Vac 50 Hz single-phase - 100 VA  
(Other voltage and frequency on request)

**Dimensions:** 200 x 160 x 270 mm

**Weight:** 5 kg

## SUPPLIED WITH

THEORETICAL-EXPERIMENTAL HANDBOOK  
WITH INTRODUCTION TO PRACTICAL  
EXERCISES





# PROPORTIONAL ELECTRO-PNEUMATICS KIT - LINEAR POSITION CONTROL Mod. ALP-PROL/EV

This training kit of proportional pneumatics for the control of linear position has been expressly designed for the complete development of application programs in the field of control systems of industrial automation.

This kit has been conceived for students and it is an important aid for the study and testing of control in proportional pneumatics. This kit can be used on any work bench or table and it includes the following elements, hereinafter described in detail and wholly assembled with genuine industrial components:

- rodless cylinder
- magnetic linear position sensor
- proportional pneumatic valve
- filter unit.

Kit mod. ALP-PROL/EV has been designed and prepared to work with several PID controllers of catalogue 26-D.

## TRAINING PROGRAM:

Kit mod. ALP-PROL/EV enables to carry out either a theoretical analysis and tests on the following issues:

- analyzing the actions for the automatic closed-loop control of a linear position with ON-OFF, Proportional (P), (PI), (PD) and (PID) control
- analyzing the control methods of variables via PID algorithm of industrial controller (with auto-tuning function)

## TECHNICAL SPECIFICATIONS:

The pneumatic position control kit mod. ALP-PROL/EV includes:

- a rodless cylinder (Ø 25 mm and stroke of 300 mm)
- a magnetic linear position sensor
- an electrically driven 5/3-way proportional pneumatic valve
- a filter unit with 3-2-way loop valve, dehumidifier with automatic drain, pressure reducer (0 to 8 bars) and a pressure gauge
- a flat supporting base and a sloping base of painted steel for cylinder-sensor set and proportional valve
- a spiral hose of plastic with airtight quick connect fittings, for air supply
- cables with plugs of 2 mm

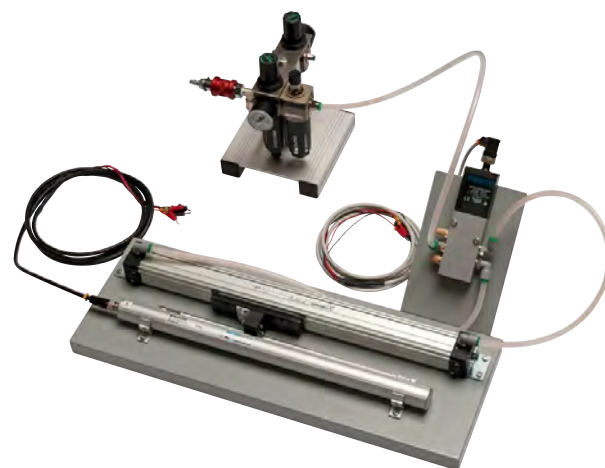

Kit mod. ALP-PROL/EV will supply the following signals to interface with external PID control units:

- 1 analog input 0-10 V
- 1 analog output 0-10 V

**Power supply:** 24 Vdc - 2A - 100 VA  
(Other voltage and frequency on request)

**Dimensions:** 750 x 200 x 300 mm

**Weight:** 15 kg

## REQUIRED INSTRUMENTS (NOT INCLUDED)

- Digital Multimeter

## UTILITIES (PROVIDED BY THE CUSTOMER)

- Compressed Air: 6 bar, 50 Nl/min max. , or
- Silenced compressor reservoir capacity 9 l mod. 3409A

## OPTIONAL

### SUGGESTED PLC:

PLC training panel Mod. PLC-V8/EV

### INDUSTRIAL PID

Single-loop PID digital controller mod. SLC/EV  
Four-loop PID digital controller mod. PID-S1/EV

### DAQ BOARDS

Industrial USB interface unit mod. MFI-U/EV

### TABLE

Working table mod. TOP/EV

**SUPPLIED WITH**  
**THEORETICAL-EXPERIMENTAL HANDBOOK**  
**WITH INTRODUCTION TO PRACTICAL**  
**EXERCISES**



# ELECTRO-PNEUMATICS KIT - SPEED CONTROL OF A PNEUMATIC MOTOR

## Mod. ALP-PROV/EV

This training kit of proportional pneumatics for speed control has been expressly designed for the complete development of application programs in the field of control systems of industrial automation.

This kit has been conceived for students and it is an important aid for the study and testing of control in proportional pneumatics. This kit can be used on any work bench or table and it includes the following elements, hereinafter described in detail and wholly assembled with genuine industrial components:

- a pneumatic motor
- a tachogenerator
- a proportional pneumatic valve
- a filter unit.

Kit mod. ALP-PROV/EV has been designed and prepared to work with several PID controllers of catalogue 26-D.

### TRAINING PROGRAM:

Kit mod. ALP-PROV/EV enables to carry out either a theoretical analysis and tests on the following issues:

- analyzing the actions for the automatic closed-loop speed control of a motor with ON-OFF, Proportional (P), (PI), (PD) and (PID) control
- analyzing the control methods of variables via PID algorithm of industrial controller (with auto-tuning function)

### TECHNICAL SPECIFICATIONS:

The pneumatic speed control kit mod. ALP-PROV/EV includes:

- a bidirectional pneumatic motor (6000 RPM max.)
- a tachogenerator (0-10 V)
- an electrically driven 5/3-way proportional pneumatic valve
- a filter unit with 3-2-way loop valve, dehumidifier with automatic drain, pressure reducer (0 to 8 bars) and a pressure gauge
- a flat supporting base and a sloping base of painted steel for cylinder-sensor set and proportional valve
- a spiral hose of plastic with airtight quick connect fittings, for air supply
- cables with plugs of 2 mm

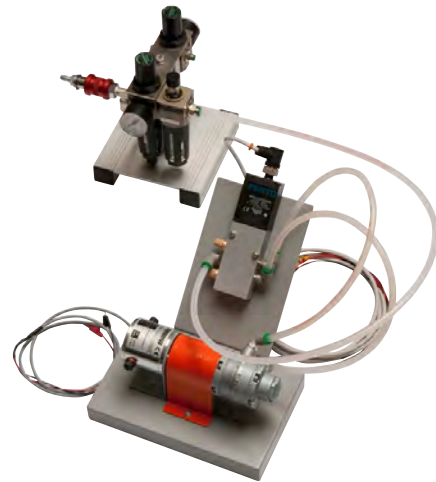

Kit mod. ALP-PROV/EV will supply the following signals to interface with external PID control units:

- 1 analog input 0-10 V
- 1 analog output 0-10 V

**Power supply:** 24 Vdc - 2A - 100 VA  
(Other voltage and frequency on request)

**Dimensions:** 400 x 150 x 300 mm

**Weight:** 10 kg

### REQUIRED INSTRUMENTS (NOT INCLUDED)

- Digital Multimeter

### UTILITIES (PROVIDED BY THE CUSTOMER)

- Compressed Air: 6 bar, 50 l/min max. , or
- Silenced compressor reservoir capacity 9 l mod. 3409A

### OPTIONAL

#### SUGGESTED PLC:

PLC training panel Mod. PLC-V8/EV

#### INDUSTRIAL PID

Single-loop PID digital controller mod. SLC/EV  
Four-loop PID digital controller mod. PID-S1/EV

#### DAQ BOARDS

Industrial USB interface unit mod. MFI-U/EV

#### TABLE

Working table mod. TOP/EV

### SUPPLIED WITH

**THEORETICAL-EXPERIMENTAL HANDBOOK  
WITH INTRODUCTION TO PRACTICAL  
EXERCISES**



# ELECTRO-PNEUMATICS KIT - FLOW CONTROL IN A PNEUMATIC LINE

## Mod. ALP-PROF/EV

This training kit of proportional pneumatics for the flow control in a pneumatic line has been expressly designed for the complete development of application programs in the field of control systems of industrial automation.

This kit has been conceived for students and it is an important aid for the study and testing of control in proportional pneumatics. This kit can be used on any work bench or table and it includes the following elements, hereinafter described in detail and wholly assembled with genuine industrial components:

- electronic flow-meter
- proportional pneumatic valve
- filter unit.

Kit mod. ALP-PROF/EV has been designed and prepared to work with several PID controllers of catalogue 26-D.

### TRAINING PROGRAM:

Kit mod. ALP-PROF/EV enables to carry out either a theoretical analysis and tests on the following issues:

- analyzing the actions for the automatic closed-loop flow control in a pneumatic line with ON-OFF, Proportional (P), (PI), (PD) and (PID) control
- analyzing the control methods of variables via PID algorithm of industrial controller (with auto-tuning function)

### TECHNICAL SPECIFICATIONS:

The kit of flow control in a pneumatic line mod. ALP-PROF/EV includes:

- an electro-pneumatic flow control valve with proportional positioner
- an electronic flow-meter
- a filter unit with 3-2-way loop valve, dehumidifier with automatic drain, 2 pressure reducers (0 to 8 bars) and 2 pressure gauges
- a flat supporting base and a sloping base of painted steel for the valve unit for the proportional flow control and the flow-meter
- a spiral hose of plastic with airtight quick connect fittings, for air supply
- cables with plugs of 2 mm

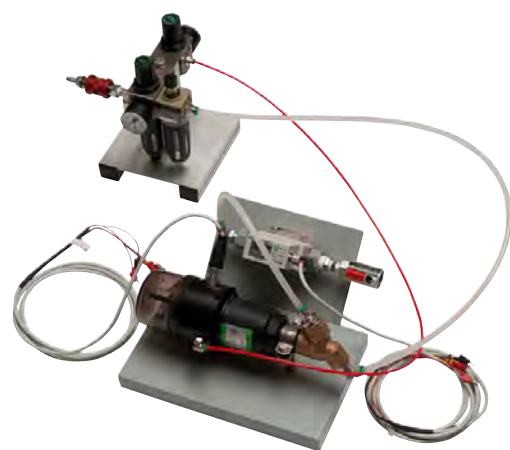

Kit mod. ALP-PROF/EV will supply the following signals to interface with external PID control units:

- 1 analog input 0-10 V
- 1 analog output 0-10 V

**Power supply:** 24 Vdc - 2A - 100 VA  
(Other voltage and frequency on request)

**Dimensions:** 500 x 150 x 300 mm

**Weight:** 12 kg

### REQUIRED INSTRUMENTS (NOT INCLUDED)

- Digital Multimeter

### UTILITIES (PROVIDED BY THE CUSTOMER)

- Compressed Air: 6 bar, 50 Nl/min max. , or
- Silenced compressor reservoir capacity 9 l mod. 3409A

### OPTIONAL

**SUGGESTED PLC:**  
PLC training panel Mod. PLC-V8/EV

**INDUSTRIAL PID**  
Single-loop PID digital controller mod. SLC/EV  
Four-loop PID digital controller mod. PID-S1/EV

**DAQ BOARDS**  
Industrial USB interface unit mod. MFI-U/EV

**TABLE**  
Working table mod. TOP/EV

**SUPPLIED WITH**  
**THEORETICAL-EXPERIMENTAL HANDBOOK**  
**WITH INTRODUCTION TO PRACTICAL**  
**EXERCISES**









# 26-D

HY



## OIL-HYDRAULICS ELECTRO OIL-HYDRAULICS PROPORTIONAL OIL-HYDRAULICS

OL

www.elettronicaveneta.com

### Aim:

- Studying the components, operational methods and programming logics of oil-hydraulic and electro-oil-hydraulic circuits, either at basic and advanced levels. Examining some topics in depth by the use of specific kits.

### Equipment:

- Trainers and kits for studying oil-hydraulics
- Trainers and kits for studying electro oil-hydraulics
- Kit for studying proportional oil-hydraulics
- Tools and accessories for developing additional activities

26D-E-HY



# 26-D

HY



## OIL-HYDRAULICS ELECTRO OIL-HYDRAULICS PROPORTIONAL OIL-HYDRAULICS

AUTOMATION TECHNOLOGIES

www.elettronicaveneta.com

26D-E-HY

<b>OIL-HYDRAULICS PRACTICAL SYSTEM</b>	Mod. KMO/EV	HY 5
<b>OIL-HYDRAULICS POWER UNIT</b>	Mod. CO/EV	HY 6
<b>ELECTRO-OIL-HYDRAULICS PRACTICAL SYSTEM</b>	Mod. KME0/EV	HY 7
<b>PROPORTIONAL OIL-HYDRAULICS PRACTICAL SYSTEM</b>	Mod. KMOP/EV	HY 8
<b>WORK-BENCH</b>	Mod. WT/EV WT2/EV	HY 9
<b>OIL-HYDRAULICS PROFESSOR TRAINER</b>	Mod. HPT/EV	HY 10
<b>SUPPLEMENTARY MODULAR PANELS</b>	Mod. SMP-P/EV	HY 12
<b>PROPORTIONAL OIL-HYDRAULIC COMPONENTS</b>	Mod. HPV-P/EV	HY 13
<b>OIL-HYDRAULICS STUDENT TRAINER</b>	Mod. HST/EV	HY 14
<b>SUPPLEMENTARY MODULAR PANELS</b>	Mod. SMP-S/EV	HY 16
<b>PROPORTIONAL OIL-HYDRAULIC COMPONENTS</b>	Mod. HPV-S/EV	HY 17
<b>TRANSPARENT OIL-HYDRAULIC COMPONENTS</b>	Mod. HVS/EV	HY 18

# OIL-HYDRAULICS PRACTICAL SYSTEM Mod. KMO/EV

The oil-hydraulics practical system has been designed to implement complete courses on oil-hydraulics.

The system is conceived for use with work-bench mod. WT/EV and consists of the following elements, which include real industrial components:

- Vertical panel for oil-hydraulic component assembly
- Set of oil-hydraulic components with quick acting couplings
- Set of hoses with quick acting couplings

Each system can be used as 2-place work-station. To operate, the oil-hydraulics practical system for the students mod. KMO/EV needs the oil-hydraulics power unit mod. CO/EV. The electro-oil-hydraulic practical system mod. KMEO/EV and the proportional oil-hydraulics system mod. KMOP/EV have been designed and manufactured to supplement the oil-hydraulic practical system for the students mod. KMO/EV.

## TRAINING PROGRAM:

The program suggests different exercises among which:

- Analysis of the operation of the supplied components
- Q-p characteristics of the pump
- Control of a single-acting actuator
- Control of a double-acting actuator
- Control of a hydraulic motor
- Regenerative circuit
- Sequential cycle of two actuators
- Actuator operation at different speeds
- Use of the hydraulic accumulator in emergencies

## TECHNICAL SPECIFICATIONS:

### Vertical panel

Omega guides are fixed on the panel in order to fit all the supplied oil-hydraulic components and the panel is supplied with the following fixed elements:

- Single- or double-acting cylinder with adjustable load,  $\varnothing 1 = 25$ ,  $\varnothing 2 = 14$ ,  $l = 200$
- Double-acting differential cylinder,  $\varnothing 1 = 32$ ,  $\varnothing 2 = 22$ ,  $l = 150$
- Membrane accumulator,  $V = 1,4$  l, pre-loading of  $N_2 = 25$  bar
- Reversible hydraulic gear motor,  $5.6$  cm<sup>3</sup>/rev

### Set of oil-hydraulic components

- Flowmeter
- 2 shut-off valves



- 1 pressure relief and/or sequence valve
- 1 4/2 bistable solenoid valve, lever control
- 1 closed-center 4/3 solenoid valve, lever control, 3 fixed positions
- 2 non-return valves
- 1 piloted non-return valve
- 2 one-way flow control valve
- 1 adjustable one-way throttle valve
- 1 pressure reducing valve

### Set of couplings and hoses

- 4 quick acting couplings with 0-100 bar pressure gauge
- 10 flexible hoses with quick-acting couplings

All the described oil-hydraulic components are provided with quick acting couplings.

**Dimensions:** 100 x 40 x 85 cm

**Weight:** 97 kg

## REQUIRED

- Oil-hydraulics power unit mod. CO/EV

## OPTIONAL

- Electro-oil-hydraulics practical system mod. KMEO/EV
- Proportional electro-oil-hydraulics practical system (open and closed-loop) mod. KMOP/EV
- Work-bench mod. WT/EV
- Design, simulation and animation software for the study of electro-pneumatics & electro oil-hydraulics mod. SW-FLU/EV

**SUPPLIED WITH**  
**THEORETICAL-EXPERIMENTAL HANDBOOK**  
**WITH INTRODUCTION TO THE EXERCISES**  
**INSTALLATION, USE AND MAINTENANCE**  
**HANDBOOK**





# OIL-HYDRAULICS POWER UNIT Mod. CO/EV

HY

The power unit provides the power supply to all the oil-hydraulics automation equipment.

It can be connected to the following equipment:

- Oil-hydraulics practical system mod. KMO/EV
- Electro-oil-hydraulics practical system mod. KMEO/EV
- Proportional oil-hydraulics practical system mod. KMOP/EV

It is mounted on a mobile trolley, and is provided with electrical power supply board, drawer and wheels.



## TECHNICAL SPECIFICATIONS:

- Power: 0.75 kW
- Maximum pressure: 60 bar
- Flow-rate: 6 l/min
- Tank: 12 l
- Pressure relief valve
- Non-return valve
- Suction and exhaust filters
- Level indicator
- Quick-acting couplings for oil inlet, exhaust and draining

**Power supply:** 230 Vac 50 Hz single-phase  
(Other voltage and frequency on request)

**Dimensions:** 85 x 50 x 100 cm

**Weight:** 66 kg

## SUPPLIED WITH

INSTALLATION, USE AND MAINTENANCE  
HANDBOOK



# ELECTRO-OIL-HYDRAULICS PRACTICAL SYSTEM

## Mod. KMEO/EV

The electro-oil-hydraulics practical system has been designed to implement complete courses on electro-oil-hydraulics automation.

This system is only supplied to complete the oil-hydraulics practical system for the students mod. KMO/EV and uses of the hydraulics power supply, the actuators, the valves.

### TRAINING PROGRAM:

The program suggests different exercises among which:

- Manual controls
- Semi-automatic controls
- Automatic controls
- Emergency controls
- "L" cycle with two solenoid valves
- Square cycle with one solenoid valve
- Actuator operation at different speeds

### TECHNICAL SPECIFICATIONS:

The system consists of the following elements which include real industrial components:

- 4/2 single solenoid valve
- 4/3 double-solenoid valve
- 5 electromechanical limit switches
- Low voltage electric control board with:
  - power supply: 24 Vdc, 2A;
  - spare fuses
  - 4 quick acting couplings for limit switches (1 NO contact + 1 NC contact)
  - 4 quick acting couplings for solenoid valve supply
  - 2 pushbuttons (1 NO + 1 NC)
  - 1 self-blocking emergency pushbutton (1 NO + 1 NC);
  - 2 relays (2 NO + 2 NC)
  - 30 electrical cables

**Dimensions:** 40 x 40 x 45 cm

**Weight:** 11 kg



### OPTIONAL

- Interface board mod. C2-IO/EV
- Design, simulation and animation software for the study of electro-pneumatics & electro oil-hydraulics mod. SW-FLU/EV

**SUPPLIED WITH**  
THEORETICAL-EXPERIMENTAL HANDBOOK  
WITH INTRODUCTION TO THE EXERCISES  
INSTALLATION, USE AND MAINTENANCE  
HANDBOOK



# PROPORTIONAL OIL-HYDRAULICS PRACTICAL SYSTEM Mod. KMOP/EV

HY

The proportional oil-hydraulics practical system provides a clear and fast approach the applications of open-loop and closed-loop controls.

This system is only supplied to complete the oil-hydraulics practical system for the students mod. KMO/EV and uses of the hydraulics power supplies, the actuators, the valves.

## TRAINING PROGRAM:

The program suggests different exercises among which:

- Open-loop speed control, for hydraulic motor (one-way and bidirectional)
- Closed-loop speed control, for oscillating motor (axis control for robot)

## TECHNICAL SPECIFICATIONS:

The system consists of the following elements which include real industrial components:

- Proportional single-solenoid valve
- Oscillating motor with transducer
- 1 single loop PID Controller mod. SLC/EV (included)
- 24 Vdc regulated power supply (230 V – 50/60 Hz; 115 V on request)

**Dimensions:** 40 x 40 x 40 mm

**Weight:** 13 kg



**SUPPLIED WITH**  
THEORETICAL-EXPERIMENTAL HANDBOOK  
WITH INTRODUCTION TO THE EXERCISES  
INSTALLATION, USE AND MAINTENANCE  
HANDBOOK



# WORK-BENCH

## Mod. WT/EV Mod. WT2/EV

- Painted steel structure
- Painted and varnished sheet steel drawer unit with 4 drawers (mod. WT/EV)
- 2 Painted and varnished sheet steel drawer units with 4 drawers each (mod. WT2/EV)

### mod. WT/EV

**Dimensions:** 1200 x 750 x 870 mm

**Weight:** 80 kg



Mod. WT/EV

### mod. WT2/EV

**Dimensions:** 1900 x 1100 x 870 mm

**Weight:** 150 kg



Mod. WT2/EV

*Example of an Oil-hydraulics workstation including the following units:*

*mod. KMO/EV, CO/EV, KMEO/EV, KMOP/EV and WT/EV.*





# OIL-HYDRAULICS PROFESSOR TRAINER Mod. HPT/EV

HY



AUTOMATION TECHNOLOGIES

www.elettronicaveneta.com

26D-E-HY-HPT-0

This system provides the Teacher with the necessary tools to implement a training course on oil-hydraulic and electro-hydraulic automation techniques.

The trainer includes an oil-hydraulic station, an electrical control board and measurement instruments.

Thanks to connections via quick-connect hoses, teachers can analyze the components and carry out the exercises explained in the handbook. This equipment is provided with castors.

#### The trainer includes:

- Oil-hydraulic station with oil-hydraulic safety devices
- Automatic oil heating and cooling system
- Thermal Magnetic Circuit Breaker T.M.C.B.
- Low voltage electrical control switchboard
- Industrial hydraulic components installed on panels with test points of pressure, quick connectors and symbols
- Measurement instruments for oil pressure, flow and temperature

#### TRAINING PROGRAM:

The program includes different exercises such as:

- Analysis of the operation of the supplied components
- Determination of the pumps Q-p characteristic
- Hydraulic and electrical control circuit for single- and double-acting cylinder
- Locking of double-acting cylinder
- Speed control with regulator

#### TECHNICAL SPECIFICATIONS:

##### Oil-hydraulics station

- Electrical motor power: 1,5 kW - 900 rev/min
- Pump flow 1:1,5 l/min
- Pump flow 2:8,2 l/min
- 2 suction filters
- 2 pressure relief valves
- 2 pressure gauges with cut-off valves
- Max. pressure: 65 bar
- Oil content: 80 l
- Min. and max. oil level indicators
- Oil filling and draining taps
- Oil thermostat and digital thermometer
- Oil heater power: 2 kW
- Water circulation heat exchanger
- Thermostatic cooling valve

**Electrical control board**

- Earth Leakage Circuit Breaker E.L.C.B.
- 2 automatic switches
- Key-operated main switch
- Self-locking emergency pushbutton
- Signalling lamps
- Run and stop motor pushbuttons
- 2 multi-position switches
- 5 relays and 4 pushbuttons
- Delayed pick-up timer and electrical cables

**Oil-hydraulic components modular panels**

- 2 pressure relief valves
- Adjustable bidirectional throttle valve
- 2 adjustable one-way throttle valves
- Flow control valve
- 3 check valves
- Pilot control check valve
- 2 shut-off valves
- 3 4/2 single-solenoid valves
- Double-acting cylinder
- Cylinder with negative load and adjustable cushions
- Hydraulic accumulator with safety devices
- 4 pressure gauges
- Tank for flow measurements and flexible hoses with quick acting couplings

**Dimensions and Weight:**

- **Trainer:** 195 x 73 x 189 cm – 429 kg (Hydraulic fluid: 80 kg)
- **Provided panels:** 88 kg
- **Electrical control board:** 60 x 60 x 189 cm – 144 kg
- **Optional rack:** 168 x 75 x 162 cm – 77 kg

**Rack for modular panels mod. MAGZ/EV****REQUIRED****UTILITIES (PROVIDED BY THE CUSTOMER)**

- Electrical power supply: 400 V 50 Hz three-phase  
(Other voltage and frequency on request)
- Hydraulic power supply: Water for oil cooling 2m<sup>3</sup>/h max

**OPTIONAL**

- Supplementary modular panels mod. SMP-P/EV
- Proportional oil-hydraulics components mod. HPV-P/EV
- Interface board mod. C2-IO/EV
- Rack for modular panels mod. MAGZ/EV

**SUGGESTED SOFTWARE:**

- Design, simulation and animation software for the study of hydraulics and electro-hydraulics mod. SW-HYD/EV

**OR AS AN ALTERNATIVE:**

- Design, simulation and animation software for the study of electro-pneumatics & electro oil-hydraulics mod. SW-FLU/EV
- Design, simulation and animation software for industrial automation mod. SW-CAI/EV.

**SUPPLIED WITH**

**THEORETICAL-EXPERIMENTAL HANDBOOK  
WITH INTRODUCTION TO THE EXERCISES**



# SUPPLEMENTARY MODULAR PANELS Mod. SMP-P/EV

HY

The extension of oil-hydraulic components that can be used with the equipment mod. HPT/EV enables the development of an intense program on oil-hydraulic and electro-hydraulic automation techniques.

The supplementary panels widen the educational possibilities of the trainer mod. HPT/EV and include:

- Industrial oil-hydraulic components specifically modified for educational purposes, with pressure test points, quick acting couplings and mounted on modular panels complete with standard symbols.
- Hydraulic connections with flexible hoses and quick acting couplings on the front panels.



## TRAINING PROGRAM:

The program includes several exercises among which:

- Functional analysis of all the supplied components
- Primary, secondary and branching flow control
- Regenerative circuit
- Electrical and hydraulic control circuit for two-cylinder sequential cycle
- Electrical and hydraulic control circuit for various cylinder rotation speeds
- Electrical and hydraulic control circuit for hydraulic motor

## TECHNICAL SPECIFICATIONS:

### Oil-hydraulics components on modular panels:

- 2 fixed throttle valves
- Flow control valve with check valve
- Pressure reducing valve with indirect control
- Pressure relief valve with indirect control
- 2 sequence valves with indirect control
- 4/3 double solenoid valve
- Double-acting differential cylinder
- Reversible hydraulic motor
- Antishock valve
- Flexible hoses with quick acting connections

**Dimensions:** 162 x 84 x 54 cm

**Weight:** 90 kg

**SUPPLIED WITH**  
**THEORETICAL-EXPERIMENTAL HANDBOOK**  
**WITH INTRODUCTION TO THE EXERCISES**



# PROPORTIONAL OIL-HYDRAULIC COMPONENTS

## Mod. HPV-P/EV

Set of proportional oil-hydraulic components mounted on metal plates with handles to be fitted on the oil-hydraulic teacher trainer mod. HPT/EV, providing a real view of closed-loop and open-loop control techniques and the related oil-hydraulic circuits which are fundamental for a complete program of automation and robotics.

The set of proportional oil-hydraulic components widens the educational possibilities of the trainer mod. HPT/EV and includes:

- Industrial oil-hydraulic components specifically modified for educational purposes, including pressure test-points, quick acting couplings and mounted on modular panels with standard symbols
- Hydraulic connections with flexible hoses and quick-acting couplings on the front panels



### TRAINING PROGRAM:

The program suggests different exercises among which:

- Closed-loop position control for oscillating motor
- Open-loop position control for hydraulic motor
- Closed-loop speed control for hydraulic motor
- Closed-loop slope control for combine-harvester

### TECHNICAL SPECIFICATIONS:

#### Proportional oil-hydraulic components on modular panels:

- 1 proportional single-solenoid directional control valve
- 1 line filter
- 2 oscillating motors
- 1 reversible hydraulic motor

#### Transducers

- tacho-generator
- angular position (potentiometric)
- slope (potentiometric)

#### Electronic regulators for

- position control
- speed command
- speed control

#### Measurement instruments

- digital tester
- revolution counter

**Power Supply:** 230 Vac 50 Hz single-phase - 100 VA  
(Other voltage and frequency on request)

**Dimensions:** 108 x 84 x 54 cm

**Weight:** 53 kg

### REQUIRED

#### UTILITIES (PROVIDED BY THE CUSTOMER)

- Oil-hydraulic power supply: 60 bar - 6 l/min

### SUPPLIED WITH

THEORETICAL-EXPERIMENTAL HANDBOOK  
WITH INTRODUCTION TO THE EXERCISES





# OIL-HYDRAULICS STUDENT TRAINER Mod. HST/EV

HY



AUTOMATION TECHNOLOGIES

www.elettronicaveneta.com

26D-E-HY-HST-0

This system provides the students with the necessary tools to implement a course on oil-hydraulic and electro-hydraulic automation techniques.

The trainer includes an oil-hydraulics station, an electrical control board and measurement instruments. Thanks to connections via quick-connect hoses, students can analyze the components and carry out the exercises explained in the handbook. This equipment is provided with castors.

#### The trainer includes:

- Oil-hydraulics station with oil-hydraulic safety devices
- Automatic oil heating and cooling system
- Thermal Magnetic Circuit Breaker T.M.C.B.
- Low voltage electrical control board
- Industrial hydraulic components installed on panels with test points of pressure, quick connectors and symbols
- Measurement instruments for oil pressure, flow and oil temperature

#### TRAINING PROGRAM:

The program suggests different exercises among which:

- Analysis of the operation of all the supplied components
- Determination of the pumps Q-p characteristic
- Hydraulic and electrical control circuit for single and double-acting cylinder
- Locking of double-acting cylinder
- Speed control with regulator
- Use of an hydraulic accumulator in emergencies

#### TECHNICAL SPECIFICATIONS:

##### Oil-hydraulics station

- Electrical motor power: 1,5 kW -900 rev/min
- Pump flow 1:1,5 l/min
- Pump flow 2:8,2 l/min
- 2 suction filters
- 2 pressure relief valves
- 2 pressure gauges with cut-off valves
- Max. pressure: 65 bar
- Oil content: 80 l

- Min. and max. oil level indicators
- Oil filling and draining taps
- Oil thermostat and digital thermometer
- Oil heater power: 2 kW
- Water circulation heat exchanger
- Thermostatic cooling valve

#### Electrical control board

- E.L.C.B.
- 2 automatic switches
- Key-operated main switch
- Self-locking emergency pushbutton
- Signalling lamps
- Run and stop motor pushbuttons
- 2 multi-position switches
- 5 relays and 4 pushbuttons
- Delayed pick-up timer and electrical cables

#### Oil-hydraulic components modular panels

- 2 pressure relief valves
- Adjustable bidirectional throttle valve
- 2 adjustable one-way throttle valves
- Flow control valve
- 3 check valves
- Pilot control check valve
- 2 shut-off valves
- 3 4/2 single-solenoid valves
- Double-acting cylinder
- Cylinder with negative load and adjustable cushions
- Hydraulic accumulator with safety devices
- 4 pressure gauges
- Tank for flow measurements and flexible hoses with quick acting couplings

#### Dimensions and Weight:

- **Trainer:** 195 x 73 x 189 cm – 435 kg (Hydraulic fluid: 80 kg)
- **Provided panels:** 73 kg
- **Electrical control board:** 60 x 60 x 189 cm – 144 kg
- **Optional rack:** 148 x 59 x 161 cm – 69 kg

**Rack for storing the student trainer modular panels mod. MHST/EV**



#### REQUIRED

##### UTILITIES (PROVIDED BY THE CUSTOMER)

- Electrical power supply: 400 V 50 Hz three-phase  
(Other voltage and frequency on request)
- Hydraulic power supply: Water for oil cooling 2m<sup>3</sup>/h max

#### OPTIONAL

- Supplementary modular panels mod. SMP-S/EV
- Proportional oil-hydraulics components mod. HPV-S/EV
- Interface board mod. C2-IO/EV
- Rack for modular panels mod. MHST/EV

##### SUGGESTED SOFTWARE:

- Design, simulation and animation software for the study of hydraulics and electro-hydraulics mod. SW-HYD/EV

##### OR AS AN ALTERNATIVE:

- Design, simulation and animation software for the study of electro-pneumatics & electro oil-hydraulics mod. SW-FLU/EV
- Design, simulation and animation software for industrial automation mod. SW-CAI/EV.

#### SUPPLIED WITH

**THEORETICAL-EXPERIMENTAL HANDBOOK  
WITH INTRODUCTION TO THE EXERCISES**



# SUPPLEMENTARY MODULAR PANELS Mod. SMP-S/EV

HY

The extension of oil-hydraulic components which can be used with the equipment mod. HST/EV enables the development of an intense program on oil-hydraulic and electro-hydraulic automation techniques.

The supplementary panels widen the educational possibilities of the trainer mod. HST/EV and include:

- Industrial oil-hydraulic components specifically modified for educational purposes, with pressure test points, quick acting couplings and mounted on modular panels complete with standard symbols
- Hydraulic connections with flexible hoses and quick acting couplings on the front panels



## TRAINING PROGRAM:

The program suggests different exercises among which:

- Functional analysis of all the supplied components
- Primary, secondary and branching flow control
- Regenerative circuit
- Electrical and hydraulic control circuit for two-cylinder sequential cycle
- Electrical and hydraulic control circuit for various cylinder rotation speeds
- Electrical and hydraulic control circuit for hydraulic motor

## TECHNICAL SPECIFICATIONS:

### Oil-hydraulic components on modular panels:

- 2 fixed throttle valves
- Flow control valve with check valve
- Pressure reducing valve with indirect control
- Pressure relief valve with indirect control
- 2 sequence valves with indirect control
- 4/3 double solenoid valve
- Double-acting differential cylinder
- Reversible hydraulic motor
- Antishock valve
- Flexible hoses with quick acting connections

**Dimensions:** 104 x 84 x 54 cm

**Weight:** 75 kg

**SUPPLIED WITH**  
**THEORETICAL-EXPERIMENTAL HANDBOOK**  
**WITH INTRODUCTION TO THE EXERCISES**



# PROPORTIONAL OIL-HYDRAULIC COMPONENTS

## Mod. HPV-S/EV

The proportional hydraulic components assembled on plates with proper handles for an easy coupling to the Trainer of oil control hydraulics for students mod. HST/EV, enable to upgrade the educational resources of the same trainer.

The set of proportional oil-hydraulic components provides the study of closed-loop and open-loop control techniques and the related oil-hydraulic circuits which are fundamental for a complete automation and robotics program.

The set of proportional oil-hydraulic components widens the educational possibilities of the trainer mod. HPT/EV and includes:

- Industrial oil-hydraulic components specifically modified for educational purposes, including pressure test-points, quickacting couplings and mounted on modular panels with standard symbols
- Hydraulic connections with flexible hoses and quick-acting couplings on the front panels



### TRAINING PROGRAM:

The program suggests different exercises among which:

- Closed-loop position control for oscillating motor
- Open-loop position control for hydraulic motor
- Closed-loop speed control for hydraulic motor
- Closed-loop slope control for combine-harvester

### TECHNICAL SPECIFICATIONS:

#### Proportional oil-hydraulic components on modular panels

##### Module:

- 1 proportional single-solenoid directional control valve
- 1 line filter
- 2 oscillating motors
- 1 reversible hydraulic motor

##### Transducers

- tacho-generator
- angular position (potentiometric)
- slope (potentiometric)

#### Electronic regulators for

- position control
- speed command
- speed control

#### Measurement instruments

- digital tester
- revolution counter

**Power Supply:** 230 Vac 50 Hz single-phase - 100 VA  
(Other voltage and frequency on request)

**Dimensions:** 108 x 84 x 54 cm

**Weight:** 50 kg

### REQUIRED

#### UTILITIES (PROVIDED BY THE CUSTOMER)

- Oil-hydraulic power supply: 60 bar - 6 l/min

### SUPPLIED WITH

THEORETICAL-EXPERIMENTAL HANDBOOK  
WITH INTRODUCTION TO THE EXERCISES



# TRANSPARENT OIL-HYDRAULIC COMPONENTS Mod. HVS/EV

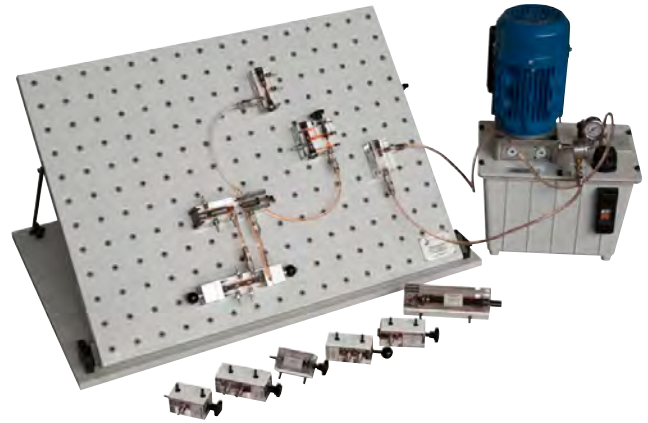

HY

Together with the provided hydraulic station, the system for using the oil-hydraulic visual software enables the direct analysis of the internal mechanism and operation of the same oil-hydraulic components.

The provided oil-hydraulic visual software describes the same industrial valves used on oil-hydraulic trainers mod. HPT/EV, mod. HST/EV and mod. KMO/EV.

The systems includes the following elements:

- Oil-hydraulics power unit
- Plexiglas industrial-type valves
- Connections with flexible hoses and quick acting couplings
- Direction of flow indicated by air introduction

## TRAINING PROGRAM:

- Analysis of the operation of the provided oil-hydraulic components.

## TECHNICAL SPECIFICATIONS:

### Oil-hydraulics power unit

- Max. pressure: 10 bar
- Max. flow: 0.5 l/min
- Pressure gauge: 0÷16 bar
- Electrical motor power: 0,12 kW
- Oil content: 6 dm<sup>3</sup>

### Plexiglas industrial-kind valves

- Check valve
- Pilot-controlled check-valve
- Bidirectional adjustable throttle valve
- One-way adjustable throttle valve
- One-way flow control valve
- Pressure relief valve, direct-acting control
- Pressure relief valve, indirect control
- Sequence valve, indirect control
- 4/2 directional control valve with lever control
- 4/3 directional control valve with lever control
- Double-acting cylinder with cushions
- 6 flexible hoses with quick acting couplings of variable length

**Power Supply:** 230 Vac 50 Hz single-phase  
(Other voltage and frequency on request)

**Dimensions:** 150 x 60 x 60 cm (operating position)

**Weight:** 54 kg

## OPTIONAL

### SUPPLEMENTARY TRANSPARENT OIL-HYDRAULIC COMPONENTS - Mod. STC/EV

- Reversible gear motor
- Oscillating motor
- Membrane accumulator
- Pressure switch
- Proportional solenoid valve
- Electronic flow control for solenoid valve
- Power supply for electronic motor: 230 V – 50/60 Hz / 24 Vdc; (115 V / 24 Vdc on request)

### SUGGESTED SOFTWARE:

- Design, simulation and animation software for the study of hydraulics and electro-hydraulics mod. SW-HYD/EV

### OR AS AN ALTERNATIVE:

- Design, simulation and animation software for the study of electro-pneumatics & electro oil-hydraulics mod. SW-FLU/EV
- Design, simulation and animation software for industrial automation mod. SW-CAI/EV.

### OVERHEAD PROJECTOR - Mod. OHP/EV

Provided with trolley, wheels and drawer

- Overhead projector:
  - lens F = 285 mm
  - 650-W halogen lamp
  - fan for cooling
  - athermic crystal between lamp and Fresnel lens
  - mechanical block to prevent the work-plane opening when under voltage
  - 5A-fuse
  - power supply cable
  - work-plane: 250 x 250 mm
  - Dimensions: 45 x 45 x 67 cm
  - Weight: 15 kg
- Trolley:
  - metal sheet steel structure, treated chemically and painted with two-color paint
  - Dimensions: 60 x 50 x 90 cm
  - Weight: 25 kg
- Mobile screen for projection (optional)

## SUPPLIED WITH

**THEORETICAL-EXPERIMENTAL HANDBOOK  
WITH INTRODUCTION TO THE EXERCISES**





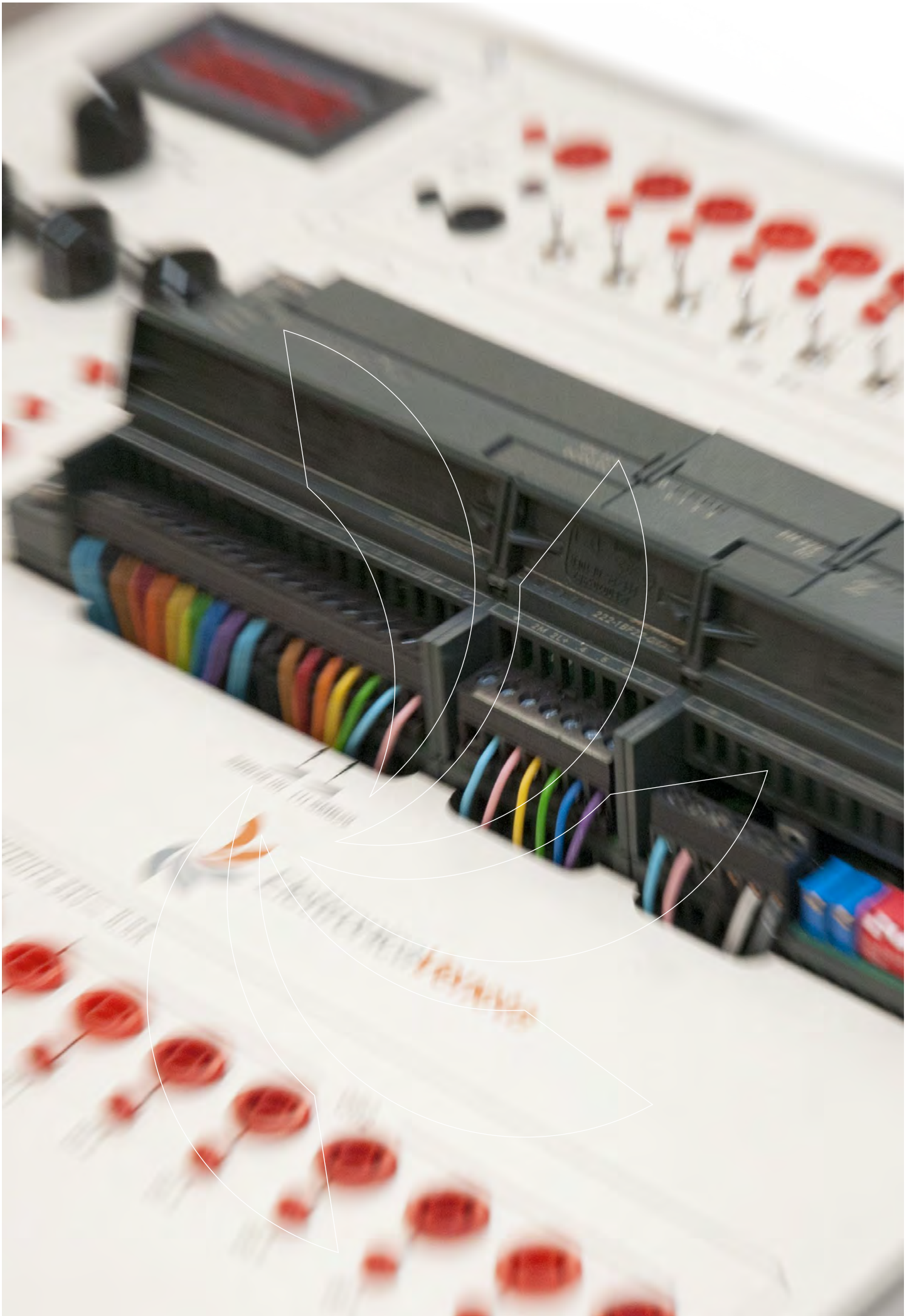

# 26-D



## PLC - SIMULATORS AND APPLICATIONS

www.elettronicaveneta.com

### **Aim:**





- Basic and high-level training on apparatuses and processes controlled by PLC. It also includes PLC programming and the study of actual industrial examples and applications.

### **Equipment:**

- PLC training panels
- PLC-controlled industrial process simulators



# PLC - SIMULATORS AND APPLICATIONS

	<b>PLC TRAINING PANELS</b>	<b>PL 4</b>
	<b>SIMULATORS OF PLC-PROGRAMMED SYSTEMS</b>	<b>PL 17</b>
	<b>SIMULATORS OF PLC-CONTROLLED INDUSTRIAL PROCESS</b>	<b>PL 20</b>
	<b>PLC-CONTROLLED APPLICATIONS</b>	<b>PL 27</b>

# 26-D



## PLC TRAINING PANELS

<b>PLC TRAINING PANEL</b>	MOD. PLC-V6/EV	PL 5
<b>PLC TRAINING PANEL</b>	MOD. PLC-V7/EV	PL 7
<b>PLC TRAINING PANEL</b>	MOD. PLC-V8/EV	PL 9
<b>INTELLIGENT LOGIC MODULE</b>	MOD. ILM-V1/EV	PL 11
<b>TOUCHSCREEN OPERATOR PANEL</b>	MOD. T7-IOP/EV	PL 13
<b>TOUCHSCREEN OPERATOR PANEL</b>	MOD. T8-IOP/EV	PL 14
<b>DCS PROCESS CONTROL SYSTEM</b>	MOD. PCS-7/EV	PL 15

# PLC TRAINING PANEL

## Mod. PLC-V6/EV

Inside a laboratory for automation technologies, the trainer mod. PLC-V6/EV is the necessary tool for the training of technicians operating industry, for installations maintenance and program designing levels. Totally carried out with industrial components, the trainer enables the development of a solid experimentation and a high content of knowledge on PLC programming and the solution of more complex problems related to automation, with particular reference to process control with HMI/SCADA software and to communication in industrial networks. The PLC installed in the trainer is one of the most powerful and used in industry. It provides many digital inputs and outputs accessible by means of terminals  $\varnothing = 4$  mm and  $\varnothing = 2$  mm present on the front panel. The digital outputs are available as relay outputs or transistor outputs for all those applications which need quicker timing. The logic state of the digital inputs and outputs is displayed via LED diodes on the PLC. The analog signals processing allows it to be used within the industrial regulations in closed-loop PID controls.

With 8 rotating potentiometers, you can adjust the voltages or currents level at the analog inputs. In this way, no external power supply is necessary for the generation of references.

The front panel of the trainer PLC-V6/EV shows the silk screen panel of the diagrams and the inner components of the equipment, complete with any name. This wide and clear vision of the system increases its teaching value, facilitating the layout of connections and the development of the exercises. A 3 and  $\frac{1}{2}$  – digits digital voltmeter displays the voltage across the analog inputs and outputs according to the position of a rotating switch. The programming software in WIN 8.1 Professional 64 Bit enables the development of programs of exercises with PLC in the most used languages of industrial automation according to IEC 61131-3 standards.

The connection between Personal Computer and PLC is made via supplied cable ethernet. Moreover, the PLC can be connected to industrial networks to **ProfiNet and Profibus DP**. At last, the development of the exercises is guided effectively by the theoretical/experimental handbooks available with the trainer.

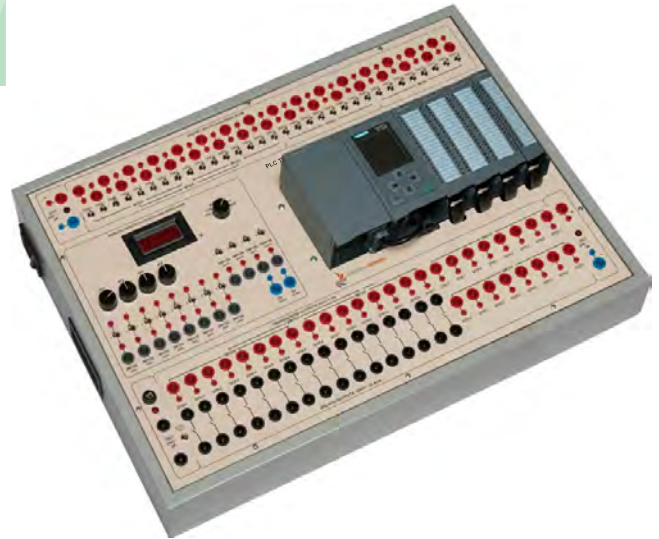

### TRAINING PROGRAM:

The trainer PLC-V6/EV enables the theoretical analysis and the experiments on the following main exercises:

- PLC architecture
- Instructions processing: the cycle concept
- Synchronous, asynchronous and priority cycles
- 8 rotating potentiometers for setting the analog references
- $\varnothing 4$  mm and  $\varnothing 2$  mm standard safety terminals for the connection of I/O to external devices
- Communication Protocol: TCP/IP
- Industrial communication interface: ProfiNet and Profibus
- Performing times, cycle and reaction
- Boolean Algebra
- **AWL, KOP, FUP, SCL, S7-GRAPH** programming
- Combinational logic functions
- Sequential logic functions
- Addressing
- Timers & counters
- Clock generators
- Monostable and bistable circuits
- Algebra operation: addition, subtraction, multiplication, division
- BCD/binary and Binary/BCD conversions
- Integrated functions of fast counting, frequency measurement, positioning
- Program Blocs
- PID control with auto-tuning
- Interrupt related to internal and external events
- Programming and use of industrial operators panels
- Industrial networks: Profinet and Profibus



**Typical application**

- Mechatronics modules

**PID regulations**

- Process control (Level, flow, pressure, temperature)

**PLC and PC Communication:**

- Inputs/Outputs diagnosis
- Internal states diagnosis
- I/O and internal variables forcing
- PLC networks (Master/Slave)

**TECHNICAL SPECIFICATIONS:**

- Tabletop metal box with press-formed aluminium section structure
- Side handles, not protruding, for easy transport in the laboratory
- Front panel, in insulating material, with silk screen representation of the diagrams and inner components of the equipment
- 24 Vdc/2 A power supply for control of the digital inputs and outputs. With electronic protection against short-circuits and overloads.
- 24 Vac/2 A power supply relay outputs control with fuse protection against overloads
- 1 3 1/2-digit digital voltmeter for measurement of the voltage present across the inputs or the analog output 0.1 Vdc resolution.
- 1 Rotating switch for voltmeter input selection
- 8 analog inputs V/I/RTD/TC 16 bit
- 4 analog outputs V/I 16 bit
- Digital inputs: 32 at 24 Vcc, groups of 16
- Digital outputs: 32 at 24 Vcc / 0,5 A
- Digital input simulator with permanent and pulse state switches
- Safety terminals, standard  $\varnothing$  4 mm and  $\varnothing$  2 mm for connection of the inputs and outputs to external devices.

**Digital outputs interfacing**

- 16 with 10 Aac/2 Adc relay
- 32 transistor for fast applications

**PLC characteristics**

- Power Supply: 24 Vdc
- Onboard CPU display (Screen diagonal: 6.1 cm)
- Level 4 protection system
- Hardware clock: YES
- Load memory: 1 MB code
- Data record: 5 MB
- Speed: 10ns Bit operation
- Integrated technology: motion, setting, counting and measuring
- Integrated tracing
- 1st interface: PROFINET IO controller, RT/IRT support, 2 ports, MRP, TCP/IP communications protocol, S7 communication, web server, routing
- 2nd interface: PROFINET basic services, TCP/IP communications protocol, server web, routing

- 3rd interface: master PROFIBUS DP
- Digital inputs: 32 at 24 Vdc, groups of 16 inputs; Input delay 0,05..20ms; input-type 3 (IEC 61131); diagnostic interrupt; process interrupt
- Input state display: green LED
- Digital outputs: 32 at 24 Vcc / 0,5 A, groups of 8 outputs, each group 4 A, diagnostic interrupt
- Output state display: LED diodes
- 8 analog inputs V/I/RTD/TC, 16 bit, groups of 8 inputs, Common-mode voltage 10V, diagnostic interrupt
- 4 analog outputs V/I, 16 bit, groups of 4 outputs, diagnostic interrupt
- Ethernet cable for connection to PC included
- Single-phase power supply cable

**Power Supply:** 230 Vac 50 Hz single-phase  
(Other voltage and frequency on request)

**Dimensions:** 415 x 400 x 150 mm

**Net Weight:** 10 kg

**INCLUDED**

**THEORETICAL-EXPERIMENTAL HANDBOOK AND APPLICATION GUIDE**



**TECHNICAL HANDBOOK ON DVD WITH CONTROLLER SPECIFICATIONS, OPERATION, MAINTENANCE AND COMMUNICATION INSTRUCTIONS**



**PLC PROGRAMMING SOFTWARE**

Software for developing PLC programs using AWL, KOP, FUP, SCL and S7-GRAPH languages and for creation of basic HMI screens. Windows 8.1 Professional (64 bit) programming environment.

**OPTIONAL**

**TOUCHSCREEN OPERATOR PANEL Mod. T7-IOP/EV**



**HMI SUPERVISION SOFTWARE Mod. SV/EV**

Industrial HMI software with graphic pages, suggested for supervision and servicing practices when using operator panels. Windows 7 Professional (32 bit/64 bit) programming environment.

# PLC TRAINING PANEL

## Mod. PLC-V7/EV

Inside a laboratory for automation technologies, the trainer mod. PLC-V7/EV is the necessary tool for the high level training of technicians operating in modern process industry. Totally carried out with industrial components, the trainer PLC-V7/EV enables the development of a solid experimentation and a high content of knowledge on PLC programming and the solution of more complex problems related to automation.

The training program includes a wide range of applications in:

- **Industrial installations**
- **Robotics**
- **Automation with conveyor**
- **Process controls with PID techniques**

The PLC installed in the trainer mod. PLC-V7/EV is one of the most powerful and used in industry. It provides many digital inputs and outputs accessible by means of terminals of two diameters ( $\varnothing$  4 mm and  $\varnothing$  2 mm) present on the front panel of the trainer. Twelve special digital inputs are used for fast counting, process alarms, frequency measurement and positioning. As concerns the digital outputs, these are available as relay outputs or transistor outputs for all those applications which need quicker timing. The logic state of the digital inputs and outputs is displayed via LED diodes on the PLC. Four analog inputs, one input for Pt100 temperature probe and two analog outputs are available for exercises involving process control.

With four rotating potentiometers and an inner stabilizer, you can adjust the voltages or currents level at the analog inputs. In this way, no external power supply is necessary for the generation of references.

The front panel of the trainer PLC-V7/EV shows the silk screen panel of the diagrams and the inner components of the equipment, complete with any name. This wide and clear vision of the system increases its teaching value, facilitating the layout of connections and the development of the exercises. A 3 and  $\frac{1}{2}$  – digits digital voltmeter displays the voltage across the analog inputs and outputs according to the position of a rotating switch. The programming software in WIN 7 Professional (32/64 Bit) enables the development of programs of exercises with PLC in the most used languages of industrial automation: **AWL, KOP, FUP, SCL, S7-GRAPH**, according to IEC 61131-3 standards.

The connection between Personal Computer and PLC is made via supplied USB interface cable and PC adapter. Moreover, the PLC can be connected to industrial networks according to Profinet e Profibus protocols. At last, the development of the exercises is guided effectively by the theoretical/experimental handbooks available with the trainer.

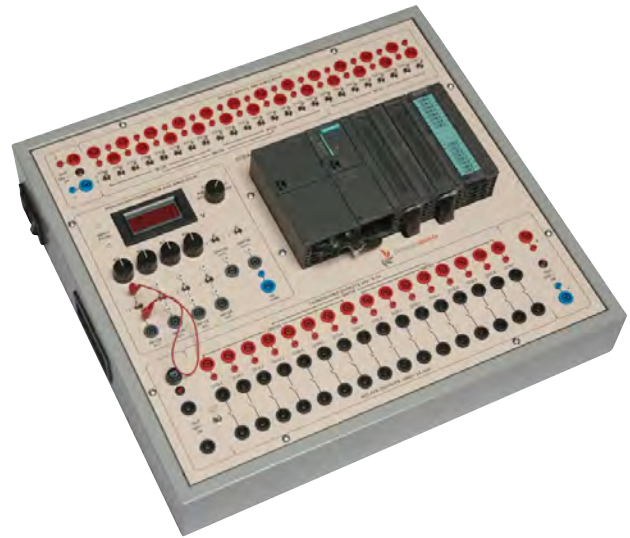

### TRAINING PROGRAM:

The trainer PLC-V7/EV enables the theoretical analysis and the experiments on the following main exercises:

- PLC architecture
- Instructions processing: the cycle concept
- Synchronous, asynchronous and priority cycles
- Performing times, cycle and reaction
- Boolean Algebra
- AWL, KOP, FUP, SCL, S7-GRAPH programming
- Combinational logic functions
- Sequential logic functions
- Addressing
- Timers & counters
- Clock generators
- Monostable and bistable circuits
- Algebra operation: addition, subtraction, multiplication
- BCD/binary conversions
- Binary/BCD conversions
- Structured programming techniques
- Basic and structured data
- Programming of functions, function blocks, data blocks
- Integrated functions of fast counting, frequency measurement, positioning
- Process interruptions management
- Industrial networks: Profinet and Profibus
- Programming and use of industrial operators panels

**Typical application**

- Mechatronics modules

**PID regulations**

- Process control (Level, flow, pressure, temperature)

**PLC and PC Communication:**

- Inputs/Outputs diagnosis
- Internal states diagnosis
- I/O and internal variables forcing
- PLC networks (Master/Slave)

**TECHNICAL SPECIFICATIONS:**

- Tabletop metal box with press-formed aluminium section structure
- Side handles, not protruding, for easy transport in the laboratory
- Front panel, in insulating material, with silk screen representation of the diagrams and inner components of the equipment
- 24 Vdc/3 A power supply for control of the digital inputs and outputs. With electronic protection against short-circuits and overloads.
- 24 Vac/3 A power supply relay outputs control with fuse protection against overloads
- 1 3 and 1/2-digit digital voltmeter for measurement of the voltage present across the inputs or the analog output 0.1 Vdc resolution.
- 1 Rotating switch for voltmeter input selection
- 4 analog inputs V/I: ±10 Vdc, ±20 mA
- 1 input for Pt 100 temperature probe
- 2 analog outputs V/I: ±10 Vdc, ±20 mA
- 4 Rotating potentiometers for setting up voltage analog references in the range 0..10 Vdc
- Inner voltage reference obtained via 24 Vdc inner stabilizer
- 24 Digital standard inputs of which 12 special for technologic functions (counting, frequency measurement max 60 kHz. Digital input simulator with permanent and pulse state switches
- Simulator block for testing the program during commissioning and operation, 16 digital inputs or 16 digital outputs or 8 digital inputs and 6 digital outputs
- 16 24 Vdc digital outputs
- Safety terminals, standard Ø 4 mm and Ø 2 mm for connection of the inputs and outputs to external devices.
- **Digital outputs interfacing**
  - With 10 Aac/2 Adc relay
  - Transistor for fast applications

**PLC characteristics**

- Power Supply: 24 Vdc
- Working memory: 192 kByte
- Load memory: 512 Kbyte with MMC
- Programming interface: RS-485
- Network interface: RS-485, Profinet, Profibus
- Communication: MPI (Multi Point Interface)
- Operating mode: Master/Slave
- Digital inputs: 24 at 24 Vdc; potential separation in groups of 4; protect. from polarity inversion. Bit, byte, word addressing

- Special digital inputs: 12 with technologic functions
- Input state display: green LED
- Digital outputs: 16 at 24 Vdc/0,5 A; galvanic separation from CPU in groups of 8; immunity against short-circuits.
- Bit, byte, word addressing
- Output state display: LED diodes
- Analog inputs: 4 voltage/current
- Temperature probe input: 1 for Pt100 probe
- A/D conversion resolution: 11 bit + sign
- Range of the analog input voltage: ±10 Vdc
- Range of the analog input current: ±20 mA
- Analog outputs: 2 voltage/current:
- D/A conversion resolution: 11 bit + sign
- Range of the analog output voltage: ±10 Vdc
- Range of the analog output current: ±20 mA
- Operating mode selector: "STOP", "RUN", "MRES"
- USB/ MPI interface
- USB cable for connection to PC
- Single-phase power supply cable

**Power Supply:** 230 Vac 50 Hz single-phase  
(Other voltage and frequency on request)

**Dimensions:** 415 x 400 x 150 mm

**Net Weight:** 10 kg

**REQUIRED (NOT INCLUDED)**

**PLC PROGRAMMING SOFTWARE mod. SW7/EV**

Software for developing PLC programs using AWL, KOP, FUP, SCL and S7-GRAPH languages and for creation of basic HMI screens. Windows 7 Professional (32 bit/64 bit) programming environment.

**INCLUDED**

**THEORETICAL-EXPERIMENTAL HANDBOOK AND APPLICATION GUIDE**



**TECHNICAL HANDBOOK ON DVD WITH CONTROLLER SPECIFICATIONS, OPERATION, MAINTENANCE AND COMMUNICATION INSTRUCTIONS**



**OPTIONAL**

**TOUCHSCREEN OPERATOR PANEL Mod. T7-IOP/EV**



**HMI SUPERVISION SOFTWARE Mod. SV/EV**

Industrial HMI software with graphic pages, suggested for supervision and servicing practices when using operator panels. Windows 7 Professional (32 bit/64 bit) programming environment.

# PLC TRAINING PANEL

## Mod. PLC-V8/EV

Inside a laboratory for automation technologies, the trainer mod. PLC-V8/EV is the necessary tool for the high level training of technicians operating in modern process industry, for installations maintenance and program designing levels. Totally carried out with industrial components, the trainer PLC-V8/EV enables the development of a solid experimentation and a high content of knowledge on PLC programming and the solution of more complex problems related to automation, with particular reference to process control with HMI/SCADA software and to communication in industrial networks.

The PLC installed in the trainer mod. PLC-V8/EV is one of the most powerful and used in industry. It provides many digital inputs and outputs accessible by means of terminals of two diameters ( $\varnothing$  4 mm and  $\varnothing$  2 mm) present on the front panel of the trainer. The digital outputs are available as relay outputs or transistor outputs for all those applications which need quicker timing. The logic state of the digital inputs and outputs is displayed via LED diodes on the PLC. The analog signals processing allows it to be used within the industrial regulations in closed-loop PID controls. With two rotating potentiometers, you can adjust the voltages or currents level at the analog inputs.

In this way, no external power supply is necessary for the generation of references.

The front panel of the trainer PLC-V8/EV shows the silk screen panel of the diagrams and the inner components of the equipment, complete with any name. This wide and clear vision of the system increases its teaching value, facilitating the layout of connections and the development of the exercises. A 3 and  $\frac{1}{2}$  – digits digital voltmeter displays the voltage across the analog inputs and outputs according to the position of a rotating switch. The programming software in WIN 7 Professional (32/64 Bit) enables the development of programs of exercises with PLC in the most used languages of industrial automation **KOP**, **FUP**, according to IEC 61131-3 standards.

The connection between Personal Computer and PLC is made via supplied Ethernet interface. Moreover, the PLC can be connected to industrial networks according to **ProfiNet** protocols. At last, the development of the exercises is guided effectively by the theoretical/experimental handbooks available with the trainer.

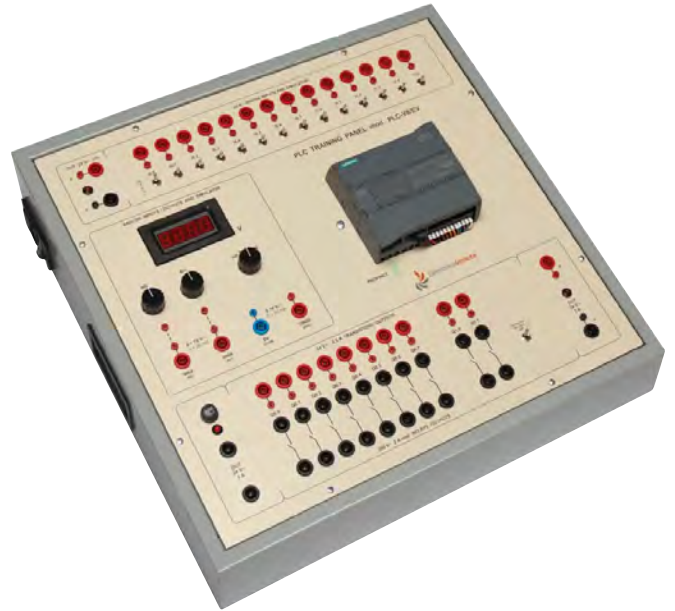

### TRAINING PROGRAM:

The trainer PLC-V8/EV enables the theoretical analysis and the experiments on the following main exercises:

- PLC architecture
- Instructions processing: the cycle concept
- Synchronous, asynchronous and priority cycles
- 2 rotating potentiometers for setting the analog references
- $\varnothing$  4 mm and  $\varnothing$  2 mm standard safety terminals for the connection of I/O to external devices
- Communication Protocol: TCP/IP
- Industrial communication interface: ProfiNet
- Performing times, cycle and reaction
- Boolean Algebra
- **KOP** and **FUP** basic programming
- Combinational logic functions
- Sequential logic functions
- Addressing
- Timers & counters
- Clock generators
- Monostable and bistable circuits
- Algebra operation: addition, subtraction, multiplication, division
- BCD/binary and Binary/BCD conversions
- Integrated functions of fast counting, frequency measurement, positioning
- Program Blocs
- PID control with auto-tuning
- Interrupt related to internal and external events
- Programming and use of industrial operators panels
- Industrial networks: ProfiNet



**Typical application**

- Mechatronics modules

**PID regulations**

- Process control (Level, flow, pressure, temperature)

**PLC and PC Communication**

- Inputs/Outputs diagnosis
- Internal states diagnosis
- I/O and internal variables forcing
- PLC networks (Master/Slave)

**TECHNICAL SPECIFICATIONS:**

- Tabletop metal box with press-formed aluminium section structure
- Side handles, not protruding, for easy transport in the laboratory
- Front panel, in insulating material, with silk screen representation of the diagrams and inner components of the equipment
- 24 Vdc/2 A power supply for control of the digital inputs and outputs. With electronic protection against short-circuits and overloads.
- 24 Vac/2 A power supply relay outputs control with fuse protection against overloads
- 1 3 and 1/2-digit digital voltmeter for measurement of the voltage present across the inputs or the analog output 0.1 Vdc resolution.
- 1 Rotating switch for voltmeter input selection
- 2 analog inputs V/I: 0÷10 Vdc, 0÷20 mA
- 1 analog output V/I: ±10 Vdc, 0÷20 mA
- 14 Digital standard inputs of which 6 special for fast counting
- Digital inputs simulator with permanent and pulse state switches
- 10 24 Vdc digital outputs of which 2 with f=100 kHz pulses
- Safety terminals, standard  $\varnothing$  4 mm and  $\varnothing$  2 mm for connection of the inputs and outputs to external devices.

**Digital outputs interfacing**

- With 10 Aac/2 Adc relay
- Transistor for fast applications

**PLC characteristics**

- Power Supply: 24 Vdc
- Hardware clock: YES
- Backup time: 240 h
- Working record: 50 kbyte
- Data record: 2 Mbyte
- Speed: 0,1  $\mu$ s for binary instruction
- Programming interface: TCP/IP
- Network interface: PROFINET
- Digital inputs: 14 at 24 Vdc; potential separation; protection from polarity inversion. Bit, byte, word addressing, from which 6 with fast counting functions
- Input state display: YES (green LED)
- Digital outputs: 10 at 24 Vdc/0,5A; galvanic separation from CPU; immunity against short-circuits. Bit, byte, word addressing from which 2 with f = 100 kHz pulses

- Output state display: YES (LED diodes)
- Analog inputs: 2 voltage/current
- Range of the analog input voltage: 0..10 Vdc
- Range of the analog input current: 0÷20 mA
- Analog outputs: 1 voltage/current
- Range of the analog output voltage: ±10 Vdc
- Range of the analog output current: 0..20 mA
- Ethernet cable for connection to PC included
- Single-phase power supply cable

**Power supply:** 230 Vac 50 Hz single-phase  
(Other voltage and frequency on request)

**Dimensions:** 415 x 400 x 150 mm

**Net Weight:** 10 kg

**LABORATORY KIT mod. KPLC-8/EV**

It is also available a laboratory kit consisting of:

- No. 6 PLC trainer panels mod. PLC-V8/EV

**INCLUDED****PLC PROGRAMMING SOFTWARE**

Software for developing PLC programs using KOP and FUP languages and for creation of basic HMI screens. Windows 7 Professional (32 bit/64 bit) programming environment.

**THEORETICAL-EXPERIMENTAL HANDBOOK AND APPLICATION GUIDE****TECHNICAL HANDBOOK ON DVD WITH CONTROLLER SPECIFICATIONS, OPERATION, MAINTENANCE AND COMMUNICATION INSTRUCTIONS****OPTIONAL****TOUCHSCREEN OPERATOR PANEL**

- Mod. T8-IOP/EV or, as an alternative
- Mod. T7-IOP/EV

**HMI SUPERVISION SOFTWARE Mod. SV/EV**

Industrial HMI software with graphic pages, suggested for supervision and servicing practices when using operator panels. Windows 7 Professional (32 bit/64 bit) programming environment.

**4-PORT RJ45 SWITCH - 24 Vdc Mod. CSM/EV**

# INTELLIGENT LOGIC MODULE

## Mod. ILM-V1/EV

Inside a laboratory for automation technologies, the trainer mod. ILM-V1/EV is the necessary tool for developing solutions and control simple automation processes. Built using industrial components, the trainer enables the development of solutions to control machines or simple installations, and can be used in the field of Building Automation or in others.

The logic module installed in the trainer is one of the most powerful and widespread in both industrial and civil field. It provides many digital inputs and outputs accessible by means of terminals of  $\varnothing 4$  mm and  $\varnothing 2$  mm present on the front panel of the trainer. The digital outputs are available as transistor outputs. The digital inputs and outputs logic state is displayed on the PLC screen. The analog signals processing allows it to be used within the industrial regulations in closed-loop PI controls.

The front panel of the trainer ILM-V1/EV shows the silk screen panel of the diagrams and the inner components of the equipment, complete with any name. This wide and clear vision of the system increases its teaching value, facilitating the layout of connections and the development of the exercises.

The programming software in WIN 8 enables the development of programs of exercises with PLC in Ladder (LAD) and Function block diagram (FBD) languages. The connection between Personal Computer and PLC is made via supplied Ethernet interface. Moreover, the PLC can be connected via Ethernet to up to 8 other ILM-V1/EV trainers.

An on-board web server allows monitoring and control via WLAN or Internet.

At last, the development of the exercises is guided effectively by the theoretical/experimental handbooks available with the trainer.



### TRAINING PROGRAM:

The trainer ILM-V1/EV enables the theoretical analysis and the experiments on the following main exercises:

- Instructions processing: the cycle concept
- Communications protocol: TCP/IP
- Boolean Algebra
- LAD and FBD basic programming
- Sequential logic functions
- Addressing
- Timers & counters
- Clock generators
- Monostable and bistable circuits
- Mathematical operations
- PI control
- PWM
- Typical applications:
  - Simple automation processes
  - Building Automation
- PI regulations:
  - Process control

## TECHNICAL SPECIFICATIONS:

- Tabletop metal box with press-formed aluminium section structure
- Side handles, not protruding, for easy transport in the laboratory
- Front panel in insulating material, with silk screen representation of the diagrams and inner components of the equipment
- 24 Vdc/1,3A power supply for control of the digital inputs and outputs. With electronic protection against short-circuits and overloads
- 12 digital standard inputs of which 2 configurable as analog
- Digital inputs simulator with permanent and pulse state switches
- 8 24 Vdc digital outputs
- Safety terminals, standard  $\varnothing$  4 mm and  $\varnothing$  2 mm for connection of the inputs and outputs to external devices.

### Logic Module features:

- Power Supply: 24 Vdc
- Ethernet interface and integrated WEBServer
- Data logging on internal memory
- Networking of up to 8 basic units over Ethernet
- Program size up to 400 function blocks in all units
- 64 analog markers
- 64 digital markers
- 4 Shift registers with 8 Bit each
- Extensive Diagnostics functions
- Configurable startup time (1 ... 10 sec.)
- Integrated display (6 x 16 characters, 3 background colors)
- Trace representation for analog signals
- Ethernet cable for connection to PC included
- Single-phase power supply cable

**Power supply:** 230 Vac 50 Hz single-phase  
(Other voltage and frequency on request)

**Dimensions:** 215 x 300 x 150 mm

**Net Weight:** 4 kg

### SUPPLIED WITH

#### PLC PROGRAMMING SOFTWARE

#### THEORETICAL-EXPERIMENTAL HANDBOOK AND APPLICATION GUIDE



### OPTIONALS

#### TOUCHSCREEN OPERATOR PANEL Mod. T7-IOP/EV



#### 4-PORT RJ45 SWITCH Mod. SIL/EV

# TOUCHSCREEN OPERATOR PANEL Mod. T7-IOP/EV

The operator panel mod. T7-IOP/EV is a suggested accessory for the PLC training panels mod. PLC-V7/EV and PLC-V8/EV. It is the necessary tool for the study of modern HMI (Human Machine Interface) technologies used in the control panels of the industrial automated machines. It can be programmed from a PC by means of a supplied specific software and can be connected to the PLC via a supplied Ethernet communication cable.

## TRAINING PROGRAM:

The industrial operator panel mod. T7-IOP/EV includes the following main exercises:

- Operator panel – PLC connection
- Creation of a program
- Display of process values
- Control and processing of exercise signals
- Set-point setting via virtual keys
- Information texts for signals

## TECHNICAL SPECIFICATIONS:

- Protective case
- TFT 7" display (16 million colours)
- Touchscreen display
- 800 x 480 pixels resolution
- 12 MB user memory
- 2 x RJ 45 for PROFINET (with integrated switch)
- 1 x RS 485/422 per PROFIBUS/MPI
- 2 x USB-host, 1 X USB-device
- 2 x SD card slot
- 2 terminals ( $\varnothing = 4$  mm) for power supply from PLC trainer
- 2 cables ( $\varnothing = 4$  mm) with safety terminals
- Ethernet cable

**Power Supply:** 24 Vdc (from PLC training panel)

**Dimensions:** 214 x 158 x 63 mm

**Weight:** 2 kg



## SUPPLIED WITH

**THEORETICAL-EXPERIMENTAL HANDBOOK  
FOR EQUIPMENT PRESENTATION AND  
GUIDE TO EXERCISES**

**TECHNICAL HANDBOOK WITH TECHNICAL  
SPECIFICATIONS, USE, MAINTENANCE, SERIAL  
COMMUNICATION**

**SUPERVISION SOFTWARE - ADVANCED LEVEL  
Mod. SV/EV (SINGLE STAND-ALONE LICENSE)**



# TOUCHSCREEN OPERATOR PANEL Mod. T8-IOP/EV

The operator panel mod. T7-IOP/EV is a suggested accessory for the PLC training panels mod. PLC-V8/EV.

It is the necessary tool for the study of modern HMI (Human Machine Interface) technologies used in the control panels of the industrial automated machines. It can be programmed from a PC by means of a specific software and can be connected to the PLC via a Ethernet communication cable.

## TRAINING PROGRAM:

The industrial operator panel mod. T8-IOP/EV includes the following main exercises:

- Operator panel – PLC connection
- Creation of a program
- Display of process values
- Control and processing of exercise signals
- Set-point setting via virtual keys
- Information texts for signals

## TECHNICAL SPECIFICATIONS:

- Protective case
- TFT 7" display widescreen
- 65.000 colours
- Touch screen and tactile buttons
- 800 x 480 pixels resolution
- 10 MB user memory
- 1 x RJ 45 for PROFINET
- 1 x USB-host
- 2 terminals ( $\varnothing = 4$  mm) for power supply from PLC trainer
- 2 cables ( $\varnothing = 4$  mm) with safety terminals
- Ethernet cable

**Power Supply:** 24 Vdc (from PLC training panel)

**Dimensions:** 214 x 158 x 63 mm

**Weight:** 2 kg

## LABORATORY KIT mod. KT8-IOP/EV

It is also available a laboratory kit consisting of:

- No. 6 PLC trainer panels mod. T8-IOP/EV



## REQUIRED (NOT INCLUDED)

PLC TRAINING PANEL - Mod. PLC-V8/EV



## SUPPLIED WITH

THEORETICAL-EXPERIMENTAL HANDBOOK  
FOR EQUIPMENT PRESENTATION AND  
GUIDE TO EXERCISES

TECHNICAL HANDBOOK WITH TECHNICAL  
SPECIFICATIONS, USE, MAINTENANCE, SERIAL  
COMMUNICATION

5-PORT INDUSTRIAL ETHERNET SWITCH,  
WITH NETWORK CABLE





# DCS PROCESS CONTROL SYSTEM Mod. PCS-7/EV

PL

AUTOMATION TECHNOLOGIES

www.elettronicaveneta.com

26D-E-PL-PCS7-0



Inside a laboratory for automation technologies, the trainer mod. PCS-7/EV, is the necessary tool for the training of technicians operating in modern process industry, for installations maintenance and program designing levels.

Totally carried out with industrial components, the trainer PCS-7/EV enables the development of a solid experimentation and a high content of knowledge on DSC system programming with particular reference to process control with SCADA software and to communication in industrial networks.

The PLC installed in the trainer is one of the most powerful and used in industry. It provides many digital inputs and outputs accessible by means of terminals of two diameters ( $\varnothing$  4 mm and  $\varnothing$  2 mm) present on the front panel of the trainer. The digital outputs are available as transistor outputs. The logic state of the digital inputs and outputs is displayed via LED diodes on the PLC via Profibus. The typical use is within the industrial regulations in closed-loop PID controls. With eight rotating potentiometers, you can adjust the voltages or currents level at the analog inputs. In this way, no external power supply is necessary for the generation of references.

The front panel of the trainer PCS-7/EV shows the silk screen panel of the diagrams and the inner components of the equipment, complete with any name. This wide and clear vision of the system increases its teaching value, facilitating the layout of connections and the development of the exercises.

Two 3 and  $\frac{1}{2}$  – digits digital voltmeter displays the voltage across the analog inputs and outputs according to the position

of a rotating switch. The programming software in WIN 7 Ultimate enables the development of programs of exercises with PLC.

The connection between Personal Computer (included) and PLC is made via ProfiNet industrial network protocol. At last, the development of the exercises is guided effectively by the theoretical/experimental handbooks available with the trainer.

## TRAINING PROGRAM:

The trainer PCS-7/EV enables the theoretical analysis and the experiments on the following main exercises:

- Project and multi-project management
- System hardware configuration
- Client / Server configuration
- Plant Hierarchy
- CFC language: standard blocks program library, test and compiling, run sequence
- SFC language: flow chart structures, connections with CFC, compiling and test
- SCL language, how to create custom blocks, compiling and test
- How to use WinCC as PCS/OS
- Performance of Multi projects control

## Typical application

- PID regulations: Process control (level, flow, pressure, temperature)

## TECHNICAL SPECIFICATIONS:

- Tabletop sheet steel structure, chemically treated and painted with epoxy paint
- Front panel, in insulating material, with silk screen representation of the diagrams and inner components of the equipment
- 24 Vdc/2A power supply for control of the digital inputs and outputs. With electronic protection against short-circuits and overloads
- 2 3 and 1/2-digit digital voltmeters for measurement of the voltage present across the inputs or the analog output 0.1 Vdc resolution.
- 2 Rotating switches for voltmeter input selection
- 8 analog inputs V: 0÷10 Vdc, 14 bit
- 8 analog output V: 0÷10 Vdc, 12 bit
- 144 Digital standard inputs, 24 Vdc
- Digital inputs simulator with permanent and pulse state switches
- 64 digital outputs, 24 Vdc
- Safety terminals, standard  $\varnothing$  4 mm and  $\varnothing$  2 mm for connection of the inputs and outputs to external devices
- Ethernet cable for connection to PC and single-phase power supply cable

### PLC features

- Power supply: 24Vdc
- SIMATIC PCS 7 AS RTX Automation System with CORE2 DUO 1.2 GHZ processor, 800 MHZ FSB, 3MB SLC, 2GB DDR3 1066 SODIMM RAM, 4 GB COMPACT-FLASH CHANGEABLE, CP5611 ONBOARD.

**Power supply:** 230 Vac 50 Hz single-phase  
(Other voltage and frequency on request)

**Dimensions:** 1230 x 450 x 810 mm

**Net Weight:** 20 kg

### INCLUDED

**PERSONAL COMPUTER**  
running Windows O.S.



**THEORETICAL-EXPERIMENTAL  
HANDBOOK AND APPLICATION GUIDE**

### PROGRAMMING SOFTWARE

Software for program development.  
WIN 7 Ultimate environment



### OPTIONAL

**PROCESS CONTROL  
MULTIVARIABLE SYSTEM  
MOD. FLTP/EV**





# SIMULATORS OF PLC-PROGRAMMED SYSTEMS

PROGRAMMABLE SYSTEMS SIMULATOR

Mod. SSP-1/EV

PL 18

# PROGRAMMABLE SYSTEMS SIMULATOR

## Mod. SSP-1/EV

Simulating various systems and installations is very useful in training practice; in fact, the physical part of an installation is often complex and cumbersome, but in the meantime it is essential from a functional point of view; simulators are designed to replace this part of systems.

System Simulator mod. SSP-1/EV is equipped with 20 interchangeable masks, thus it can reproduce different installations with sequential and analog control. Simple electric connections can interface the process reproduced on the mask to PLC inputs and outputs. Processes are represented on masks via LEDs, bargraphs, pushbuttons, limit switches, etc...

Users can write the control program in the programmable controller or they can use the programs supplied with the controller that can also be customized.

This System Simulator consists of a basic module that houses the various masks corresponding to the system having to be simulated, from time to time. This simulator is also equipped with a handbook including some exercises already developed for each mask (available also on CD) for PLC training panel mod. PLC-V7/EV (not included).

### TRAINING PROGRAM:

The training program includes the following exercises:

#### 1 - FILLING A BIN

Managing the process control for filling a bin

#### 2 - ELEVATOR

Controlling an elevator moving on 4 floors

#### 3 - PEDESTRIAN TRAFFIC LIGHT

Controlling a traffic light unit on main road with pedestrian crossing

#### 4 - STARTING AN ASYNCHRONOUS WOUND-ROTOR MOTOR

Controlling the starting sequence by 1, 2 or 3 (selectable) steps. Resetting the initial conditions at stop

#### 5 - STARTING DAHLANDER MOTOR

Controlling the HIGH / LOW motor speed

#### 6 - REVERSAL OF ROTATION OF ASYNCHRONOUS MOTOR

Controlling the direction of rotation of the motor

#### 7 - STAR-DELTA START OF ASYNCHRONOUS MOTOR

Controlling the D/Y starting sequence at adjustable times; resetting the initial conditions at stop

#### 8 - SEQUENTIAL NEON SIGN

Controlling different programs of sequential lighting of 1 to 8 lamps, with separate variation of lighting times; operation: AUTO/MAN and UP/DOWN



#### 9 - DRINK MACHINE

Simulating the different operation sequences of a drink machine

#### 10 - REACTOR

Managing the reaction with control of refrigerant (hot and cold) and of mixer

#### 11 - MIXER

Controlling the mixing process of different substances

#### 12 - STARTING AN ASYNCHRONOUS MOTOR

Starting sequence of an asynchronous motor

#### 13 - CAR PARK

Controlling a car park with indications of "FULL" and of "FREE BAYS"

#### 14 - COMPRESSED AIR NETWORK

Controlling compressors and tank for production and distribution of compressed air

#### 15 - CONVEYOR BELTS 1

Transport of sandy material controlled by three conveyor belts

#### 16 - CONVEYOR BELTS 2

Controlling conveyor belts for the transport of various products

#### 17 - FILLING SYSTEM 1

Automatic filling process of tablets

#### 18 - FILLING SYSTEM 2

Filling process of three tanks

#### 19 - MACHINING LINE

Implementation of different sequences by the use of all the phase or of some of them

#### 20 - MONITORING THE OPERATION OF FOUR PUMPS

Controlling the operation of four pumps for testing pressure inside a distribution network

## TECHNICAL SPECIFICATIONS:

This System Simulator consists of a panel that can be used as tabletop unit or mounted on vertical frame.

It includes 12 inputs and 12 digital outputs connected via safety leads with plugs of Ø 4 mm. Two potentiometers enable to set two analog variables (0 – 10 V) used, for instance, to indicate the filling rate of a bin, the up and down movements of an elevator, etc...

6 instantaneous contacts held by switches and 6 LEDs of state indication are available on the fore panel.

A bargraph display will show the level of a tank or the position of an elevator; 6 electric limit switches enable to monitor the minimum/maximum positions, as well as the intermediate positions.

<b>Power supply:</b>	24 Vdc (output by the PLC)
<b>Dimensions:</b>	390 x 297 x 100 mm
<b>Net weight:</b>	5 kg

## SUPPLIED ACCESSORIES:

Set of 24 leads with safety plugs (Ø 4 mm)

## SYSTEM REQUIREMENTS - PLC:

- 12 positive-logic digital inputs
- 12 digital outputs, 24 Vdc
- 2 analog inputs, 0-10 Vdc
- 2 analog output, 0-10 Vdc

## RECOMMENDED PLC:

For a better educational experience use PLC Training panel mod. PLC-V7/EV (not included).

## AS AN ALTERNATIVE:

PLC Training panel mod. PLC-V8/EV (not included). Remark: Mask 14 - *Compressed air network* cannot run with this PLC.

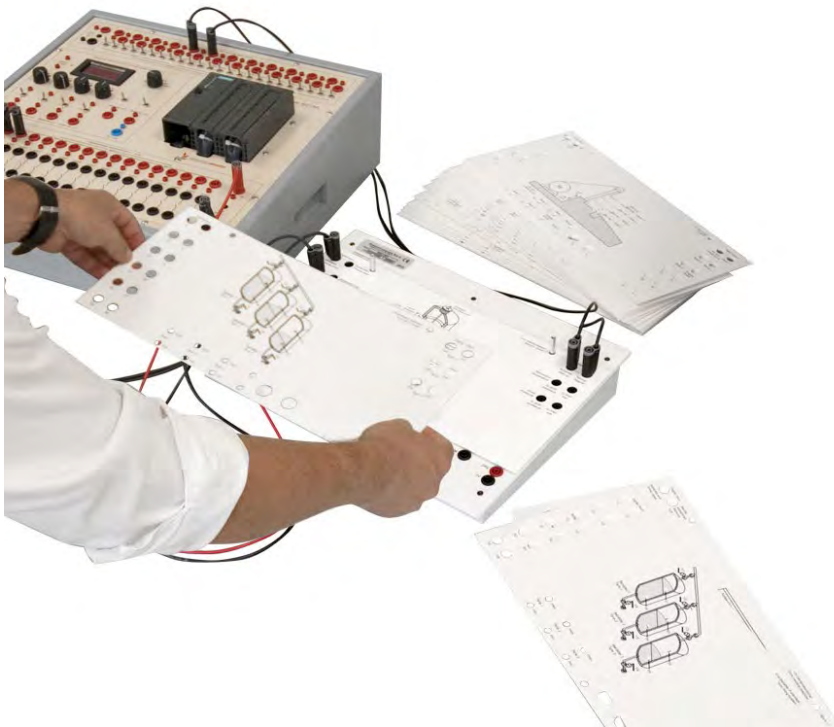

*Example of configuration with a PLC training panel (not included)*

**SUPPLIED WITH**  
**THEORETICAL-EXPERIMENTAL HANDBOOK**  
**WITH INTRODUCTION TO THE EXERCISES**





# 26-D

PL



AUTOMATION TECHNOLOGIES

## SIMULATORS OF PLC-CONTROLLED INDUSTRIAL PROCESS

**PROCESS SIMULATOR FOR MOLDING  
PLASTIC MATERIALS**

Mod. IMS/EV

PL 21

**IRON PROCESS SIMULATOR**

Mod. SPS/EV

PL 23

**PACKAGING PROCESS SIMULATOR**

Mod. PPS/EV

PL 25

www.elettronicaveneta.com

26D-E-PL

# PROCESS SIMULATOR FOR MOLDING PLASTIC MATERIALS Mod. IMS/EV

PL

The simulator mod. IMS/EV has been designed and manufactured for the interactive and complete study of a molding process for plastic materials.

It is composed of:

- A panel reporting the color silk screen diagram of a real industrial plant
- Multimedia graphical software enabling, via PC simulator connection:
  - the control and supervision of the system
  - the consultation of theoretical hypertexts and digitized images

The center of the simulator mod. IMS/EV consists of the industrial press that produces the finished object via injection molding starting from solid granules of polymer. The simulator reproduces all functions and conditions of the molding plant enabling the analysis of many technological subjects such as:

- Molding polymers
- Operation and automation of an injection press
- Types of molds
- Cooling techniques for the press and the mold
- Safety on the molding systems

The presence on the panel of many potentiometers, pushbuttons, switches, LED diodes and graphic bars enables to easily manipulate the values of the process variables. These actions can be carried out from PC, too, with the help of the interactive software enabling at the same time the real time report of the process state by means of dynamic graphical objects.

At last, the theoretical study, the exercises and the use of the simulator mod. IMS/EV are effectively guided by a complete theoretical/practical set of handbooks provided with the equipment.

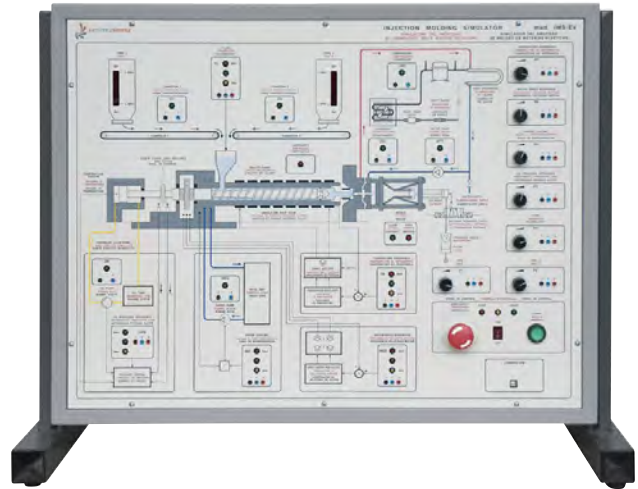

## TRAINING PROGRAM:

The simulator mod. IMS/EV enables the study of the following main subjects:

- Structure of a molding system
- Molding materials
- Structure, operation and automation of the industrial injection press
- Extrusion process
- Injection process
- Press cooling systems
- Types of molds
- Mold blocking systems
- Mold cooling systems
- Mold cooling times
- Quality control (QC) of the finished object
- Safety of the molding plants
- Emergency and alarms
- Monitoring and control of the molding process via PC

## TECHNICAL SPECIFICATIONS:

- Sheet steel structure, chemically treated and painted with epoxy paint
- Colored silk-screen panel representing the plant
- Setting and manipulation of the process variables via:
  - Potentiometers
  - Pushbuttons
  - Switches
- Visualization of the process variables via:
  - LED diodes
  - Bargraph
- Electronic card for control of the digital and analog I/O on the simulator provided with USB interface for communication with PC
- USB cable for simulator/PC communication

**Power Supply:** 230 Vac 50 Hz single-phase - 50 VA  
(Other voltage and frequency on request)

**Dimensions:** 900 x 710 x 450 mm

**Net Weight:** 30 kg

## MULTIMEDIA SOFTWARE:

Graphical software for supervision and service enabling:

- Real-time display of the process dynamics
- Sending of commands to the simulator
- Manipulation of the process variables
- Definition of graphs and tables
- Creation of databases concerning the process
- Process diagnostics
- Consulting of hypertexts and digitized images

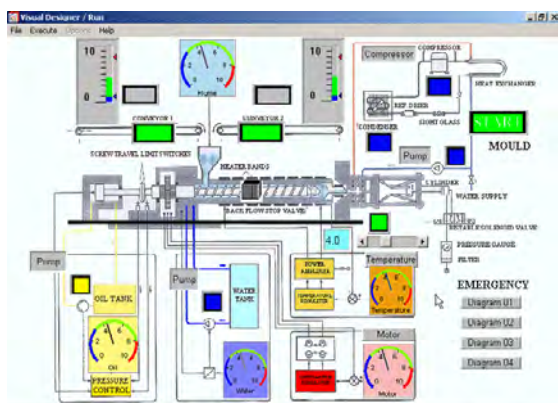

### REQUIRED

**PERSONAL COMPUTER**  
- NOT INCLUDED -



**SUPPLIED WITH**  
**THEORETICAL-EXPERIMENTAL HANDBOOK**  
**WITH INTRODUCTION TO THE EXERCISES**  
**INSTALLATION, USE AND MAINTENANCE**  
**HANDBOOK**



# IRON PROCESS SIMULATOR

## Mod. SPS/EV

PL

The simulator mod. SPS/EV has been designed and manufactured for the interactive and complete study of a real iron process, starting from raw materials up to the finished product consisting in a continuous casting.

It is composed of:

- A panel reporting the color silk screen diagram of a real industrial plant
- Multimedia graphical software enabling, via PC simulator connection:
  - the control and supervision of the system
  - the consultation of theoretical hypertexts and digitized images.

The center of the simulator mod. SPS/EV consists of the blast furnace divided into its different sections (DOOR, SHAFT, BELLY, POT), that produces cast iron starting from loaded materials (mineral, coke, fluxes and additions). The simulator reproduces all functions and conditions of the iron plant, enabling the analysis of many technological subjects such as:

- Prime materials in iron industry
- Preparation of the load materials
- Structure and operation of a blast furnace
- Automation of blast furnace
- Oxygen converters
- Processing of the casting
- Safety in iron plants

The presence on the panel of many potentiometers, pushbuttons, switches, LED diodes and graphic bars enables to easily manipulate the values of the process variables. These actions can be carried out from PC, too, with the help of the interactive software enabling at the same time the real time report of the process state by means of dynamic graphical objects.

At last, the theoretical study, the exercises and the use of the simulator mod. SPS/EV are effectively guided by a complete theoretical/practical set of handbooks provided with the equipment.

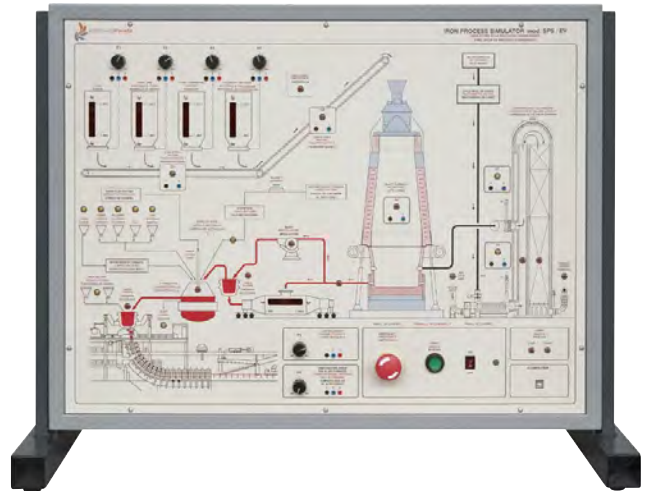

### TRAINING PROGRAM:

The simulator mod. SPS/EV enables the study of the following main subjects:

- Prime materials in iron industry
- Structure of a blast furnace
- Operation and automation of a blast furnace
- Preparation of the load materials
- Cokery materials and sub-products
- Recirculation of the cokery and blast furnace gases
- Taking and transport of cast iron: torpedo truck
- Steel production
- Structure and operation of the converter with oxygen thrower
- Structure and operation of the ladle
- Processing of the casting
- Continuous casting: production of flat blooms
- Safety in iron plants
- Emergency and alarms
- Monitoring and control of the iron process via PC

## TECHNICAL SPECIFICATIONS:

- Sheet steel structure, chemically treated and painted with epoxy paint
- Colored silk-screen panel representing the plant
- Setting and manipulation of the process variables via:
  - Potentiometers
  - Pushbuttons
  - Switches
- Visualization of the process variables via:
  - LED diodes
  - Bargraph
- Electronic card for control of the digital and analog I/O on the simulator provided with USB interface for communication with PC
- USB cable for simulator/PC communication

**Power Supply:** 230 Vac 50 Hz single-phase - 50 VA  
(Other voltage and frequency on request)

**Dimensions:** 900 x 710 x 450 mm

**Net Weight:** 30 kg

## MULTIMEDIA SOFTWARE:

Graphical software for supervision and service enabling:

- Real-time display of the process dynamics
- Sending of commands to the simulator
- Manipulation of the process variables
- Definition of graphs and tables
- Creation of databases concerning the process
- Process diagnostics
- Consulting of hypertexts and digitized images

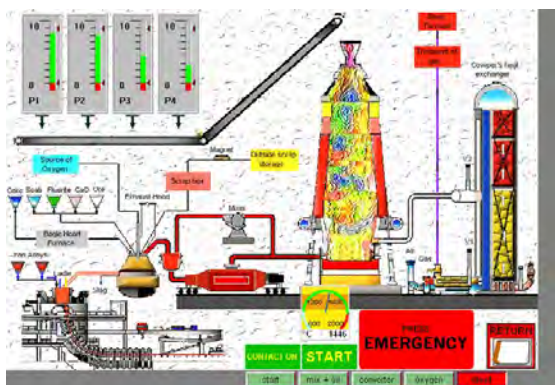

### REQUIRED

**PERSONAL COMPUTER**  
- NOT INCLUDED -



### SUPPLIED WITH

**THEORETICAL-EXPERIMENTAL HANDBOOK  
WITH INTRODUCTION TO THE EXERCISES  
INSTALLATION, USE AND MAINTENANCE  
HANDBOOK**





# PACKAGING PROCESS SIMULATOR

## Mod. PPS/EV

PL

The simulator mod. PPS/EV has been designed and carried out for the complete study of a bottling process of liquids into cylindrical containers and next packaging process with final quality control (QC).

It is composed of:

- A panel reporting the color silk screen diagram of a real industrial plant
- Multimedia graphical software enabling, via PC simulator connection:
  - the control and supervision of the system;
  - the consultation of theoretical hypertexts and digitized images.

The center of the simulator mod. PPS/EV consists of the automated machine filling the empty containers with mixed and properly dosed liquid substances. The simulator reproduces all functions and conditions of the packaging plant enabling the analysis of many technological subjects such as:

- Automated dosing systems
- Motion
- Automated filling machines
- Computerized weighting systems
- Packaging systems
- Safety in the packaging systems

The presence on the panel of many potentiometers, pushbuttons, switches, LED diodes and graphic bars enables to easily manipulate the values of the process variables. These actions can be carried out from PC, too, with the help of the interactive software enabling at the same time the real time report of the process state by means of dynamic graphical objects.

At last, the theoretical study, the exercises and the use of the simulator mod. PPS/EV are effectively guided by a complete theoretical/practical set of handbooks provided with the equipment.

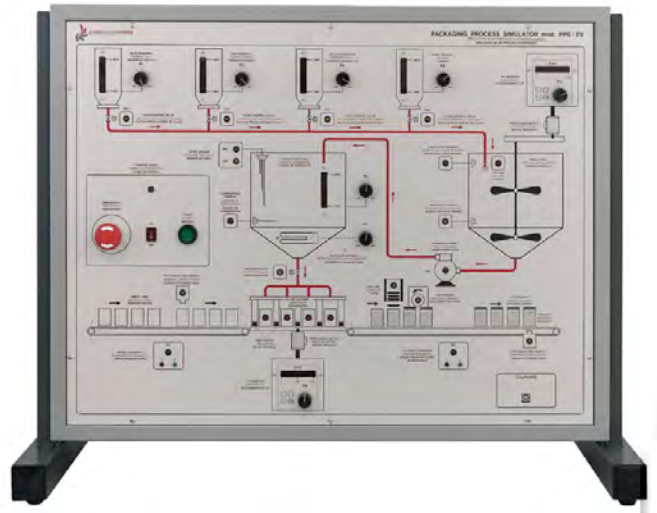

### TRAINING PROGRAM:

The simulator mod. PPS/EV enables the study of the following main subjects:

- Industrial packaging plants
- Automated dosing of liquid and solid substances
- Mixers of liquid substances
- Inner motion systems
- Structure and automation of a filling machine
- Logistics
- Safeties on the packaging plants
- Emergency and alarms
- Monitoring and control of the iron process via PC

## TECHNICAL SPECIFICATIONS:

- Sheet steel structure, chemically treated and painted with epoxy paint
- Colored silk-screen panel representing the plant
- Setting and manipulation of the process variables via:
  - Potentiometers
  - Pushbuttons
  - Switches
- Visualization of the process variables via:
  - LED diodes
  - Bargraph
- Electronic card for control of the digital and analog I/O on the simulator provided with USB interface for communication with PC
- USB cable for simulator/PC communication

**Power Supply:** 230 Vac 50 Hz single-phase - 50 VA  
(Other voltage and frequency on request)

**Dimensions:** 900 x 710 x 450 mm

**Net Weight:** 30 kg

## MULTIMEDIA SOFTWARE:

Graphical software for supervision and service enabling:

- Real-time display of the process dynamics
- Sending of commands to the simulator
- Manipulation of the process variables
- Definition of graphs and tables
- Creation of databases concerning the process
- Process diagnostics
- Consulting of hypertexts and digitized images

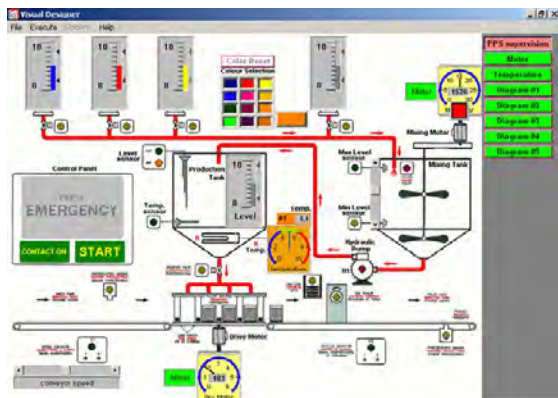

### REQUIRED

**PERSONAL COMPUTER**  
- NOT INCLUDED -



**SUPPLIED WITH**  
**THEORETICAL-EXPERIMENTAL HANDBOOK**  
**WITH INTRODUCTION TO THE EXERCISES**  
**INSTALLATION, USE AND MAINTENANCE**  
**HANDBOOK**





# PLC-CONTROLLED APPLICATIONS

---

**ADVANCED 3-FLOOR LIFT**

MOD. HM-410/EV

PL 28

---

**BASIC 3-FLOOR LIFT**

MOD. LDIDA/EV

PL 30

---

# ADVANCED 3-FLOOR LIFT

## Mod. HM-410/EV

The unit is a tabletop structure reproducing a 3-floor lift. As in real installations, several sensors and controls are used for the cabin motion & positioning and the doors opening, such as pushbuttons inside the cabin and at each floor.

The front of the unit includes 3 automatic floor doors, and the related call pushbuttons and pilot lamps indicating the cabin movement.

Both the floor and the cabin doors are controlled by electrical motors (with reversing gear for opening and closing); two limit switches are used in each case for these operations. The cabin door includes a photocell to inhibit the door closing when the users are passing through.

The cabin is driven by an electrical motor (with inversion); several limit switches are used for the cabin approaching and stop at each floor. Cabin safety over travel limit switches are also included.

The cabin is able to be controlled with two speeds: fast speed for the motion among floors, and slow speed for the floors approaching.

The cabin pushbuttons are placed in the front of the unit and include: three pushbuttons for the cabin movement between floors, a STOP pushbutton, and an emergency call (simulated by an electronic ringtone). Three spy lamps are included for floor indication (control device and cabin-signaling).

It is possible to manage the unit according to following modes:

- Stand-alone operation with internal microprocessor board;
- PLC control with 24 Vdc operating voltage and at least 20 digital inputs and 16 digital outputs; PLCs with less I/O cannot allow to develop all the functions.
- TTL circuits control with 5 Vdc operating voltage,
- Supervision with PC through USB port in LABVIEW environment.

### TRAINING PROGRAM

The automation process with the 3-floor lift mod. HM-410/EV enables the theoretical analysis and the experiments on the following main exercises:

- Microswitches
- Relays
- ON/OFF drives of a DC motor
- Lift systems

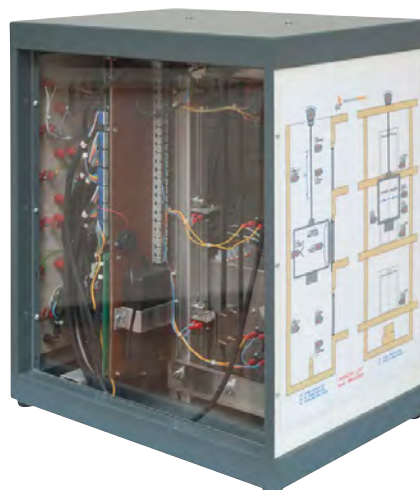
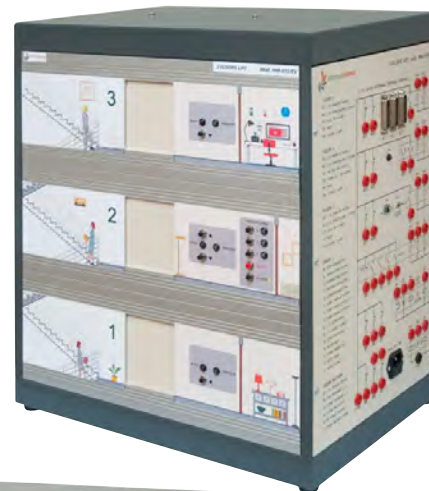

### TECHNICAL SPECIFICATIONS

- Treated and epoxy-painted steel structure reproducing a 3-floor lift.
- Insulating material side synoptic panel with 4mm-dia. safety terminals for the electrical connections to any PLC or control board; 25 pin-connectors for quick connection to our PLC training panel mod. PLC-V7/EV (not included).
- 3 automatic doors with opening/closing electrical motors.
- 1 automatic cabin door with opening/closing electrical motor and photocell for users' safety.
- 4 microswitches for doors closing control.
- 3 limit microswitches for cabin stop at each floors.
- 4 limit microswitches for the cabin floors approach.
- 2 microswitches for cabin over travel.
- Cabin motion with electrical motor controlled by relays UP/ DOWN and speed-change.

Pushbuttons and limit switches refer to a common terminal with no electrical potential, the actuating/signaling devices accept input electrical signals in 5 to 24Vdc range.

Electrical elements available for PLC and interface boards connections with to 4mm-dia. safety terminals.

#### 1<sup>st</sup> FLOOR

- Floor call pushbutton with NO contact
- 'On-service' signaling LED
- Limit switch for 'closed door' signaling
- Motor control for 1<sup>st</sup> floor door closing
- Motor control for 1<sup>st</sup> floor door opening

#### 2<sup>nd</sup> FLOOR

- Floor call pushbutton with NO contact
- 'On-service' signaling LED
- Limit switch for 'closed door' signaling
- Motor control for 2<sup>nd</sup> floor door closing
- Motor control for 2<sup>nd</sup> floor door opening

#### 3<sup>rd</sup> FLOOR

- Floor call pushbutton with NO contact
- 'On-service' signaling LED
- Limit switch for 'closed door' signaling
- Motor control for 3<sup>rd</sup> floor door closing
- Motor control for 3<sup>rd</sup> floor door opening

#### CABIN

- Pushbutton for motion to 1<sup>st</sup> floor, NO contact
- Pushbutton for motion to 2<sup>nd</sup> floor, NO contact
- Pushbutton for motion to 3<sup>rd</sup> floor, NO contact
- LED for signaling cabin at 1<sup>st</sup> floor
- LED for signaling cabin at 2<sup>nd</sup> floor
- LED for signaling cabin at 3<sup>rd</sup> floor
- STOP pushbutton with NC contact
- Emergency call pushbutton, NO contact
- Limit switch for 'closed door' signaling
- Cabin reflection photocell for users' safety
- Motor control for cabin door opening & closing

#### COMMON DEVICES

- Motor control for cabin upward / downward
- Motor control for cabin-motion first / second speed.
- Limit microswitch for cabin stop at 1<sup>st</sup> floor
- Limit microswitch for cabin stop at 2<sup>nd</sup> floor
- Limit microswitch for cabin stop at 3<sup>rd</sup> floor
- Limit microswitch for cabin low over travel stop
- Limit microswitch for cabin top over travel stop
- Limit microswitch for cabin approaching to 1<sup>st</sup> floor
- 2 limit microswitches for cabin approaching to 2<sup>nd</sup> floor
- Limit microswitch for cabin approaching to 3<sup>rd</sup> floor
- Electronic ringtone for emergency
- Mechanic characteristics:
  - Silk screen synoptic
  - Sheet steel structure painted
  - Plexiglas transparent panel
  - DC gear motor coupled to a system of pulleys with a belt for the cabin motion

A PLC (not included) is needed to control the process. Minimum requirements:

- 21 24 Vcc digital inputs
- 16 24 Vcc 0,5 A digital outputs

#### Suggested PLC:

- n° 1 PLC training panel mod. PLC-V7/EV with programming and simulation software mod. SW7/EV

#### Alternative:

- n° 1 PLC training panel mod. PLC-V6/EV

**Power Supply:** 230 Vca 50 Hz Single-phase  
(Other voltage and frequency under request)

**Dimensions:** 500 x 350 x 600 mm

**Weight:** 15 kg

#### INCLUDED

**THEORETICAL-EXPERIMENTAL MANUAL  
WITH APPLICATION GUIDE**



#### SET OF 35 1M-CABLES

With 4mm-diam. safety terminals

#### OPTIONAL

**SUPERVISION AND CONTROL SOFTWARE IN LABVIEW  
ENVIRONMENT AND 2.0 USB CABLE A/B TYPE, MALE  
CONNECTOR**



# BASIC 3-FLOOR LIFT

## Mod. LDIDA/EV



Trainer mod. LDIDA/EV has been designed to simulate a 3-floor lift commonly used in multi-storey buildings.

The trainer reproduces all different components and features of an actual lift, such as the opening/closing of the doors, a variable speed motor to control the movement, presence sensors at each floor, as well as alarm and emergency buttons. The cabin is fixed on a mobile cart driven by a low voltage DC motor controlled by pulleys.

Call buttons are available on a panel at each floor. LEDs indicate the elevator status (free/busy). Switches simulate the door status (open/closed) at each floor. Other LEDs located at each floor signal the current position of the cabin. Each panel includes a LED to signal the possible activation of the alarm button in the cabin.

#### The cabin operating panel includes:

- 3 LEDs signaling the current position of the lift
- 5 call/stop/alarm buttons
- A LED and a buzzer signal the alarm situation
- A LED simulates lighting in the cabin
- A switch simulates the cabin door status (open/closed)
- More LEDs signal the cabin door status (open/closed)
- Micro-switches are used as limit switches to protect the engine in case the cabin runs off track
- Micro-switches at each floor are used as starting point of the deceleration and of the cabin stop

- 3 relays with LEDs control the motor direction and speed

A silk-screen panel reproduces the structure of the lift and features alerts, calls, stops and direction of the cabin. All process inputs / outputs are connected independently to the PLC by means of Ø 2 mm terminals

The aim of the equipment is to teach students how to program a PLC to control the operation of a lift.

#### TRAINING PROGRAM:

- System analysis
- System I/O setup
- Process flow diagram generation
- Step-by-step sequence
- Logical process flow diagram generation
- Evaluation of potential problems
- Program development

## TECHNICAL SPECIFICATIONS:

### Electric characteristics

- 10 limit switches
- 9 LEDs signaling the cabin at the floor
- 3 LEDs signaling the cabin speed and direction of travel (up/down)
- 4 requested floor buttons
- 9 LEDs signaling the lift status at the floor (free/busy/alarm)
- 3 switches simulating if the cabin door status at the floor (open /closed)
- 6 LEDs signaling the cabin door status at the floor (open / closed)
- 1 diverter switch reproducing the open /closed cabin door status
- 2 LEDs signaling if the cabin door is open or closed
- 1 LED to light the cabin
- 3 floor request buttons
- 1 emergency stop button
- 1 alarm button
- 3 LEDs signaling the position at the floors
- 1 LED signaling an alarm status
- 1 Buzzer signaling an alarm status
- 1 DC gear motor
- Connection to the PLC by means of  $\varnothing$  2 mm terminals

### Mechanic characteristics

- Silk screen synoptic
- Vertical aluminum frame with an external box for the interface
- DC gear motor coupled to a system of pulleys with a belt for the cabin motion

A PLC (not included) is needed to control the process. Minimum requirements:

- 20 24 Vcc digital inputs
- 14 24 Vcc 0,5 A digital outputs

### Suggested PLC:

- n°1 PLC training panel mod. PLC-V7/EV with programming and simulation software mod. SW7/EV

### Alternative:

- n°1 PLC training panel mod. PLC-V6/EV

**Power Supply:** 24 Vcc – 0.5A (supplied by the PLC)

**Total dimensions:** 655 x 297 x 100 mm

**Weight:** 3 kg

## INCLUDED

THEORETICAL-EXPERIMENTAL MANUAL  
WITH APPLICATION GUIDE





# 26-D



## PROCESS CONTROLS

**Aim:**

- Learning the basic mechanisms of automatic process control and drilling, at an advanced level, on the control instruments available in industry.

**Equipment:**

- Modular automatic process controls
- Multivariable process control system
- Bench top process control units with onboard PLC



[www.elettronicaveneta.com](http://www.elettronicaveneta.com)





# PROCESS CONTROLS - TRAINING UNITS

<b>MODULAR AUTOMATIC PROCESS CONTROLS</b>	Mod. APC-900/EV	PC 5
<b>FOUR LOOPS PID DIGITAL CONTROLLER</b>	Mod. PID-S1/EV	PC 8
<b>PROCESS CONTROL MULTIVARIABLE SYSTEM</b>	Mod. FLTP/EV	PC 10
<b>PROCESS CONTROL BENCH TOP UNITS:</b>		
<b>FLOW-RATE CONTROL</b>	Mod. FCBp/EV	PC 12
<b>LEVEL CONTROL</b>	Mod. LCBp/EV	PC 14
<b>PRESSURE CONTROL</b>	Mod. PCBp/EV	PC 16
<b>TEMPERATURE CONTROL</b>	Mod. TCBp/EV	PC 18
<b>pH CONTROL</b>	Mod. pHCBp/EV	PC 20

# MODULAR AUTOMATIC PROCESS CONTROLS Mod. APC-900/EV

The system enables the training of instrument technicians and users in the field of industrial process controls. In particular, it is suitable to study courses where the familiarization with the concepts of process, regulation and stability are required. The different command and control blocks are electronic kind but appear as modules which input/output relation is important to be known.

## MODULAR AUTOMATIC PROCESS CONTROLS mod. PT/EV, mod. PLP/EV, mod. PP/EV, mod. PV/EV, mod. PPL/EV, mod. CPL/EV, mod. TF/EV, mod. TSL/EV, mod. SP/EV

Using a frame for vertical mounting of the modules and the power supply unit, the different cards are assembled for conditioning, setting, regulation and display of signals that are connected to the studied process. This kind of mounting enables to use the system also for collective explanations and demonstrations. The main characteristics are:

- Wide range of transducers and actuators
- Many controlled processes
- Use of electronic regulators
- A/D and D/A interface for connection to Personal Computer

## TRAINING PROGRAM:

- Analysis and calibration of the signal conditioners
- Detection of the characteristic curve of the transducers
- Determination of the linearity of the transducers
- Determination of the response delay of transducers and signal conditioners
- Analysis of the On/Off, three-state, proportional, integrative and derivative actions of the controller
- Detection of the transfer functions of the power amplifiers
- Determination of the time constants of the single processes
- Controller set-up according to:
  - response at stability limit
  - process index response
  - process frequency response
- Detection of the closed-loop processes response with On/Off or Three-state controller
- Detection of the closed-loop processes response with P, P+I, P+D, P+I+D controller
- Open loop processes: comparison of the responses with closed-loop processes
- Comparison of the sensitivity to the open-loop and closed-loop load variations



- Detection of the permanent state error and the processes, according to the used controller
- Detection of the transient state behavior of the processes, according to the controller time constants

## TECHNICAL SPECIFICATIONS:

The system is considered in the different subdivisions of group of modules and components, so to enable the users to configure the equipment according to their needs.

### Basic system

It provides the essential units to carry out the process control and is common to all the analyzed processes. Besides the power supplies and the module-holder frame, it includes the module to provide the SET-POINT signal to the process, the P.I.D. controller module for the proportional, derivative and integrative actions, the module for ON/OFF control with 2- or 3-position module and display module for the analog signals via LED diode bars.

It consists of:

- Module-holder frame **mod. VF2/EV**
- Power supply: 115/230 Vac  $\pm 10\%$ , 50/60 Hz; outputs:  $\pm 12$  Vdc/0.5A, 24 Vac/5A, +5 Vdc/2A, 30 Vdc/5A **mod. MU5A/EV**
- Analog set-point module **SP-1**
- P.I.D. controller module **PC-1**
- 2 and 3-position controller module **PC-2**
- Voltage indicator module **VI-1**

### Temperature process mod. PT/EV

The process unit includes the thermal actuators consisting in a double resistor and a fan and three different kinds of usable industrial temperature transducers (PTC, RTD and thermocouple).

Beside the basic modules of the system, there is the power amplifier module for heating and cooling actuators and the conditioning modules of the signals provided by the three kinds of usable sensors.

The system includes:

- Process unit PU-1
- Amplifier module PA-1A
- Signal conditioner module for P.T.C. SC-1A
- Signal conditioner module for RTD SC-1B
- Signal conditioner module for thermocouple SC-1C

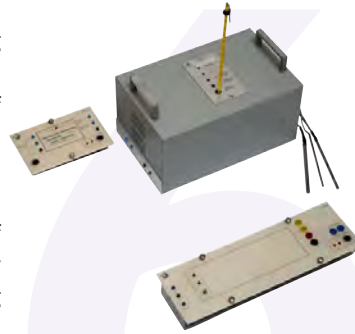

### Level and flow process mod. PLP/EV

The process unit consists of a tank with pump to provide the liquid necessary to reach and keep the level. The actuator consists of a proportional valve while the level transducer consists in a pressure sensor set at the bottom of the process tank. A windmill flowmeter with a manual throttle valve set in series on the delivery pipe enables to carry out flow measurements. Beside the basic modules of the system, there is the power amplifier module for the level and flow actuators and the conditioning modules of the signals provided by the two level and flow transducers.

The system includes:

- Process unit PU-2
- Amplifier module PA-2
- Signal conditioner module for level transducer SC-2A
- Signal conditioner module for flow transducer SC-3A



### Pressure process mod. PP/EV

The process unit consists of a tank and a compressor activated by an electrical motor providing the air necessary to reach and keep the pressure. The actuator consists of a proportional valve and the pressure transducer is piezoresistive.

Besides the basic modules of the system, there is also a power amplifier for the pressure unit and the conditioning modules of the signals for the pressure transducer.



The system includes:

- Process unit PU-4
- Amplifier module PA-2
- Signal conditioner module for pressure transducer SC-4A

### Angular speed process mod. PV/EV

The process unit consists of a bidirectional permanent magnets d.c. motor. A tachogenerator and an incremental encoder of optical kind – which are the transducers - are splined on the axis. The actuator consists of a DC motor.

Beside the basic modules of the system, there is the power amplifier module for the angular speed and the conditioning modules of the signals for the speed and angular position sensors.

The system includes:

- Process unit PU-6
- Amplifier module PA-6
- Signal conditioner module for tacho-generator SC-6A
- Signal conditioner module for feedback reaction SC-6B
- Signal conditioner module for photoelectric speed transducer SC-6C



### Linear position process mod. PPL/EV

The microprocessor position control drives the motion of a single-axis translator by reading from bidirectional incremental encoder.

The microprocessor controller is the processing unit of the position control and is complete with display and keyboard for data insertion and display. A D/A converter module is used to control the analog section of the position control while a second module enables the display of the logic state of the output lines of the microprocessor controller. There are also the conditioning modules for the speed and position sensors.

Beside the base modules, the system includes:

- Process unit PU-7
- Amplifier module PA-6
- Microprocessor digital control module CU-1
- Display and keyboard for module CU-1 DK-1
- 12-bit D/A converter module DA-1
- 8-bit I/O module IO-1
- Signal conditioner module for tachogenerator SC-6A
- Signal conditioner module for incremental encoder SC-7A

### Luminosity process mod. CPL/EV

The process unit consists of a dark chamber where the actuator of the light processing is inserted which consists of an incandescent lamp and three semiconductor luminosity transducer devices.

Beside the basic modules of the system, there is the power amplifier module for the luminosity unit and the conditioning modules of the signals for the sensors.



The system includes:

- Process unit PU-9
- Amplifier module PA-9
- Signal conditioner module for photoresistor SC-9A
- Signal conditioner module for photodiode SC-9B
- Signal conditioner module for phototransistor SC-9C

#### Force transducer mod. TF/EV

The system consists of a strain gauge load cell and a conditioning module for the generated signal. Beside the module-holder frame and the power supply, the system includes:

- Force transduction unit TU-5
- Signal conditioner module for load cell SC-5A



#### Linear shift transducer mod. TSL/EV

The system consists of an L.V.D.T. (Linear Variable Differential Transformer) and potentiometric position transducer and the conditioning modules of the generated signals.

Beside the module-holder frame and the power supply, the system includes:

- Position transduction unit TU-7C
- Signal conditioner module for L.V.D.T. SC-7C
- Signal conditioner module for linear potentiometer SC-7D



#### Proximity sensors mod. SP/EV



The system consists of a linear inductive proximity sensor, an ON/OFF inductive sensor and an ON/OFF capacitive sensor and the conditioning modules for the generated signals. Beside the module-holder frame and the power supply, the system includes:

- Proximity transduction unit TU-8
- Signal conditioner module for linear inductive sensor SC-8A
- Signal conditioner module for On-Off inductive sensor SC-8B
- Signal conditioner mod. for On-Off capacitive sensor SC-8C

#### PERSONAL COMPUTER INTERFACING

To detect the data from the transducers and the actuators of the processes, an acquisition interface is used which provides a set of analog, digital interfaces, counters and timers.

The DMA input/output functions (direct access to the CPU) and simultaneous input/output control for command/response applications (signal acquisition from transducers, signal transmission of control signals to the actuator...) are also supported.

- Industrial interface card mod. MFI-U/EV

#### REQUIRED (NOT INCLUDED)

- **SOFTWARE**
  - Data acquisition from transducers, process. of intermediate variables in the conditioning and display circuits via virtual instruments mod. SW-TW/EV
  - Transmission of the control and acquisition variable, processing and supervision of the process variables mod. SW-PW/EV
- **PERSONAL COMPUTER**
- **INSTRUMENTS:** multimeter, oscilloscope

#### SUPPLIED WITH

**THEORETICAL-APPLICATION HANDBOOK WITH GUIDE TO THE PROCESS CONTROL APPLICATIONS**  
**INSTALLATION, USE AND MAINTENANCE HANDBOOK**

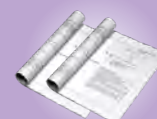

# FOUR LOOPS PID DIGITAL CONTROLLER Mod. PID-S1/EV

As with the present generation of PID controllers, the Four Loops PID Digital Controller mod. PID-S1/EV has a structure based on a high performance microcontroller, analog inputs and outputs, programming of the regulation functions and serial interface for the communication with Personal Computers.

The programming of the main parameters of the process control is carried out locally through the touch screen display. The controller can find immediate application to the control of various processes (temperature, pressure, flow rate and level) since it is designed to interface with those modules.

It is provided with an Ethernet interface in order to be connected to a Personal Computer for data visualization and control.

The main function of the regulator is to control and monitor the process continuously according to the programmed regulation algorithm. The regulator controls 4 auto-tuning regulation loops.

The parameters for the P- proportional, D- derivative and I- integrative regulation are set via the touch screen display or via the PC.

The high resolution display shows the numerical or graphic trend of the variables during the regulation (Set point, Regulated quantity, Error...).

## TRAINING PROGRAM:

The equipment allows a wide range of educational applications such as:

- Analyzing the structure of a digital process regulator
- Programming the functions of the regulator;
- Analyzing the parameters: proportional, derivative and integrative coefficient;
- Analyzing the analog I/O signals and the connections with the process regulation;
- Applying algorithms to the functional programming of a digital process control;



## TECHNICAL SPECIFICATIONS:

- Front screen in isolating material with screen-printed diagrams and internal components
- Power supply unit 24 Vdc / 2 A with electronic protection against overload and short circuit
- Power supply unit 10 Vdc / 0.5 A with electronic protection against overload and short circuit
- 4 different regulation techniques:
  - Multi Loops (1 to 4 loops)
  - Ratio
  - Cascade
  - Override

When selecting a technique, the system automatically sets the corresponding parameters and gives some I/O specific functions.

- Color graphic TFT touch 4.3" display (480 x 272 pixels / colors: 16 M)
- Auto-tuning
- Alarm configuration page
- Alarm history
- Parameter page of the selected loop
- Trend page of the selected loop
- Parameter page of the analog inputs
- Parameter page of the analog outputs
- Parameter page of the digital I/O
- Status and forcing of I/O
- Time register
- Ethernet switch: on board
- Ø 2 mm jacks for instruments for connecting inputs and outputs to external devices.



**Analog inputs**

- 6 Voltage / current sortable analog inputs
- Voltage range: 0÷1 V / 0÷5 V / 1÷5 V / 0÷10 V
- Current Range: 0÷20 mA / 4÷20 mA

**Digital inputs**

- 8 optocoupled Auxiliary ON/OFF inputs (0-24 Vdc)

**Set Point**

- Local setting via the touch screen display

**Analog outputs**

- 4 voltage / current sortable analog outputs
- Voltage range: -10 V÷ +10 V / -20 V÷ +20 V / 0÷10 V
- Current Range: 4÷20 mA

**Digital outputs**

- 8 digital outputs 24 Vdc - 0.5 A

**Communication**

- 1 Ethernet interface for parameterization / supervision via PC of the regulator with Modbus TCP/IP protocol.

**On board characteristics / functions**

- High resolution color display
- Pages organized in a menu
- Visualizing the regulated figures in real-time
- Managing bar graphs, trends, alarms
- Optional use of password

**Power supply:** 110/230 Vac 50 Hz single-phase

**Dimensions:** 245 x 197 x 355 mm

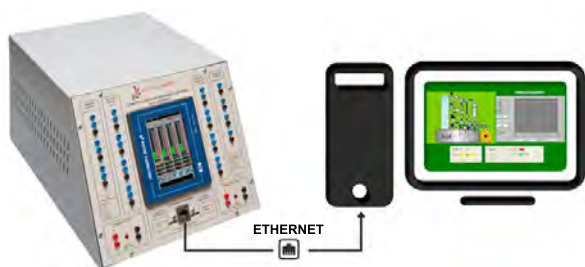

Supervision and data acquisition is carried out via the optional software mod. SV-1/EV with Modbus TCP/IP protocol.

**SUPPLIED WITH**

**THEORETICAL-APPLICATION HANDBOOK WITH GUIDE TO THE PROCESS CONTROL APPLICATIONS**  
**INSTALLATION, USE AND MAINTENANCE HANDBOOK**



**OPTIONAL**

**PROCESS SUPERVISION AND DATA ACQUISITION SOFTWARE Mod. SV-1/EV**

Powerful software with graphic pages enabling process control supervision and data acquisition from a PC station connected to the PID controller.

# PROCESS CONTROL MULTIVARIABLE SYSTEM

(Four process controls in just one trainer:  
FLOW, LEVEL, TEMPERATURE & PRESSURE)

## Mod. FLTP/EV

The system mod. FLTP/EV has been developed to cover the following educational subjects included in an intense theoretical-practical training program, as follows:

- Study of the sensors and relative signal conditioners circuits for the process variables: Flow, Level, Temperature and Pressure.
- Study of the closed ring process control techniques. Study of the different process control ways: PID control with PLC, with Industrial PID controller, with PC data acquisition card and with datalogger.

The system mod. FLTP/EV has been carried out according to industrial criteria and with real industrial components. It is composed of the following elements:

- **Process unit mod. FLTP-U/EV** with the following sensors:
  - Temperature: (Pt100, thermocouple-type J, PTC and NTC)
  - Level: (piezometric and ON/OFF sensor )
  - Flow: (turbine-type and ON/OFF magnetic sensor)
  - Pressure: (piezometric and ON/OFF sensor)
- **Control unit including:**
  - Signal amplifier modules
  - Signal coupling circuits for the control of: temperature mod. FLTP-B/EV, level and flow mod. FLTP-C/EV and pressure mod. FLTP-D/EV.

### TRAINING PROGRAM:

The system mod. FLTP/EV allows the theoretical analysis and the experiments on the following subjects:

- Detection of the characteristic curve of the transducers and the signal conditioning circuits for the temperature, flow, level and pressure sensors.
- Detection of the time constants of the processes.
- Analysis of the closed ring automatic control for flow, level, temperature and pressure: ON/OFF control mode and Proportional (P), Proportional Integral (PI), Proportional Derivative (PD) and Proportional Integral Derivative (PID) control mode.
- Analysis of the variables curves through the PID algorithm in the PLC, in the industrial PID controller (with autotuning function) and acquisition/control card for PC with dedicated software (supplied).



### TECHNICAL SPECIFICATIONS:

#### Process unit mod. FLTP-U/EV

- Metal holder with Plexiglas vertical panel
- 3 tanks: lower one in stainless steel, 25 lt. capacity; upper one (Plexiglas column), 5 lt; side one in steel, 1 lt.
- Recirculation pump, 6 lt/min 12 V - 7A
- Manual valves
- 48 V 200 W water heater
- Safety thermostat
- 1 mercury glass thermometer (-20 °C a + 110 °C).
- 2 Proportional valves, bronze body 0-10 V
- 2 manometers 0-4 bar
- External unit connection with 4 mm diameter terminals and DIN connectors
- ON/OFF solenoid valve
- Flow sensors: 1 turbine-type, 1 magnetic-type for ON/OFF control
- Level sensors: 1 ON/OFF-type, 1 piezometric-type
- Temperature sensors: 1 Pt100-type, 1 thermocouple J-type, 1 PTC-type, 1 NTC-type.
- Pressure sensor: 1 piezometric-type, 1 ON/OFF-type

**Control unit including:**

- Signal amplifiers modules
- Signal conditioners circuits for the automated control of: temperature mod. FLTP-B/EV, level and flow mod. FLTP-C/EV and pressure mod. FLTP-D/EV.
- On board power supply mod. FLTP-A/EV: Output 1: 48 V~ / 5 A; fuse protection, Output 2: 24 Vdc/1 A, Output 3: -12 Vdc/1 A and +12 V/2 A, Output 4: 12 V / 7 A fuse protection; LED for voltage indication, ON/OFF Switch for the pump control, connection terminals to the modules mod. FLTP-B/EV, mod. FLTP-C/EV and mod. FLTP-D/EV to the process unit mod. FLTP-U/EV, 4 Potentiometers for the external set-points, ranges 0-10 Vdc/10 mA.

**The following optional monitoring units can be also used (not included):****PLC Training panel**

Suggested: mod. PLC-V7/EV and mod. PLC-V8/EV

**Industrial PID**

- Single loop PID digital controller mod. SLC/EV
- Four loops PID digital controller mod. PID-S1/EV

**Datalogger:**

- EVLAB DATALOGGER mod. EV2010/EV  
with 2 Interfaces EVSI-FLTP/EV  
and one interface EVSO-FLTP/EV

**DIMENSIONS AND WEIGHT**

- External unit mod. FLTP-U/EV: 680 x 330 x 880 mm, 40 Kg
- Power supply mod. FLTP-A/EV: 415 x 460 x 110 mm, 7 kg

**POWER SUPPLY**

Power supply unit mod. FLTP-A/EV: 115/230Vac  $\pm$ 10% - 50/60Hz

**SUPPLIED WITH**  
**THEORETICAL-EXPERIMENTAL**  
**HANDBOOK**



# FLOW-RATE CONTROL

## Mod. FCBp/EV (PLC on-board)

This bench top unit enables to carry out several tests of flow-rate control and it can be connected with the water network or with the laboratory line of compressed air to reproduce the flow-rate control of a gas or of a liquid.

The flow inside the pipe is measured by a differential-pressure transmitter connected with a calibrated orifice and it is controlled by a pneumatic valve.

The on-board PLC includes a PID algorithm block and is able to manage the unit through an Ethernet communications module. This module allows the PLC to work together with an operator panel for the information exchange. The panel has several graphic pages, with the unit synoptic diagram, the open and closed control loop main parameters, and the graphic of the system response according to the working situations.

### TRAINING PROGRAM:

This unit enables to develop and analyze the following subjects:

- Proportional, Integral and Derivative control
- Open-loop control
- Closed-loop control
- Tuning a controller
- Response to a noise

### TECHNICAL SPECIFICATIONS:

- Framework of AISI 304 stainless steel
- Electronic differential-pressure transmitter of AISI 316 stainless steel, with 4 to 20 mA output signal
- Calibrated orifice of AISI 304 stainless steel
- Pneumatic control valve of AISI 316 stainless steel,  $C_v = 2.5$
- Electro-pneumatic converter, 4 to 20 mA / 0.2 to 1 bar
- Safety valve
- Bourdon gauge of stainless steel with range of 0 to 6 bar
- Pressure gauge for measuring the output signal of I/P converter
- Switchboard of painted carbon steel with synoptic, ELCB and measuring terminals for input and output signals of the controller
- Pipes and valves of AISI 304 and 316 stainless steel
- This unit can be connected in with module mod. PCBp/EV for the simultaneous control of pressure and flow rate



- Industrial PLC placed in the electrical board, including the PID control block and Ethernet communications module. It is included the standard IEC 1131 61131 programming software.
- Operator Panel, 7" TFT touchscreen display, 16 million colors, 800 x 480 pixels, with RJ45 PROFINET ports; the H.M.I (Human Machine Interface) industrial supervision software is included.

**Power Supply:** 230 Vac 50 Hz single-phase - 0,5 kVA  
(Other voltage and frequency on request)

**Dimensions:** 850 x 600 x 750 mm

**Net Weight:** 50 kg

Examples of the operator panel graphic pages:

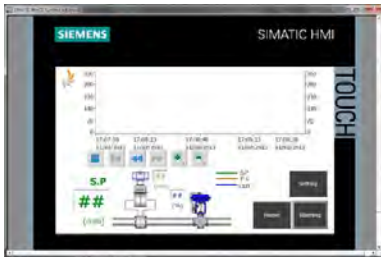
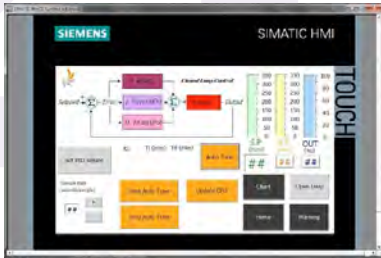
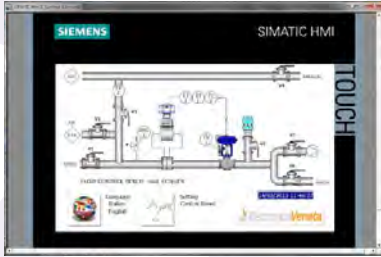

**REQUIRED**

**UTILITIES (PROVIDED BY THE CUSTOMER)**

- Tap water (valve with 1/2" hose connector):  
1000 l/h @ 2 bar max.
- Compressed air (2 female valves of 1/4"):  
0.3 Nm<sup>3</sup>/h @ 1.5 bar, for instruments, and 25 Nm<sup>3</sup>/h @ 6 bar, when air is used as process fluid

**ACCESSORIES (NOT INCLUDED)**

- Personal Computer running Windows 7 Professional (32 bit)

**SUPPLIED WITH**

**THEORETICAL-EXPERIMENTAL HANDBOOK**



**OPTIONAL**

**TWO-PEN RECORDER**

(it must be installed before shipment, not as upgrade)

**SERVICE UNIT MOD. US-1/EV**

for closed-circuit operations





# LEVEL CONTROL

## Mod. LCBp/EV (PLC on-board)

This bench top unit enables to carry out several tests of level control.

The level of a transparent tank is measured by a differential-pressure transmitter and is controlled by a pneumatic valve installed on the input of water inlet line.

The on-board PLC includes a PID algorithm block and is able to manage the unit through an Ethernet communications module. This module allows the PLC to work together with an operator panel for the information exchange. The panel has several graphic pages, with the unit synoptic diagram, the open and closed control loop main parameters, and the graphic of the system response according to the working situations.



### TRAINING PROGRAM:

This unit enables to develop and analyze the following subjects:

- Proportional, Integral and Derivative control
- Open-loop control
- Closed-loop control
- Tuning a controller
- Response to a noise

### TECHNICAL SPECIFICATIONS:

- Framework of AISI 304 stainless steel
- Pneumatic control valve of AISI 316 stainless steel,  $C_v = 1.25$
- Electronic differential-pressure level transmitter, in AISI 316 stainless steel with range of 0 to 500 mm H<sub>2</sub>O and 4 to 20 mA output signal
- Variable-area flowmeter of stainless steel and glass with range of 100 to 1000 l/h
- Electro-pneumatic converter, 4 to 20 mA / 0.2 to 1 bar
- Graduated tank of Plexiglas with capacity of 5 litres
- Pressure gauge for measuring the output signal of I/P converter
- Switchboard of painted carbon steel with synoptic, ELCB and measuring terminals for input and output signals of the controller

- Industrial PLC placed in the electrical board, including the PID control block and Ethernet communications module. It is included the standard IEC 1131 61131 programming software.
- Operator Panel, 7" TFT touchscreen display, 16 million colors, 800 x 480 pixels, with RJ45 PROFINET ports; the H.M.I (Human Machine Interface) industrial supervision software is included.

**Power Supply:** 230 Vac 50 Hz single-phase - 0,5 kVA  
(Other voltage and frequency on request)

**Dimensions:** 850 x 600 x 750 mm

**Net Weight:** 50 kg

Examples of the operator panel graphic pages:

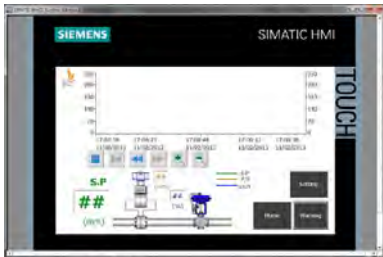
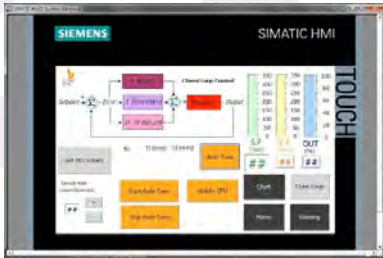
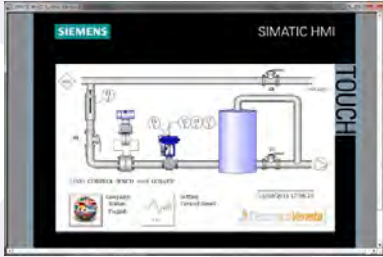

**REQUIRED**

**UTILITIES (PROVIDED BY THE CUSTOMER)**

- Tap water (valve with 1/2" hose connector): 1000 l/h @ 2 bar max.
- Compressed air (2 female valves of 1/4"): 0.3 Nm<sup>3</sup>/h@1.5 bar

**ACCESSORIES (NOT INCLUDED)**

- Personal Computer running Windows 7 Professional (32 bit)

**SUPPLIED WITH**

**THEORETICAL-EXPERIMENTAL HANDBOOK**



**OPTIONAL**

**TWO-PEN RECORDER**

(it must be installed before shipment, not as upgrade)

**SERVICE UNIT MOD. US-1/EV**

for closed-circuit operations



# PRESSURE CONTROL

## Mod. PCBp/EV (PLC on-board)

PC

AUTOMATION TECHNOLOGIES

www.elettronicaveneta.com

26D-E-PC-PCBP-0

This bench top enables to carry out several tests of pressure control. The pressure supplied by the laboratory network of compressed air, is measured by a pressure transmitter and it is controlled by a pneumatic valve inserted in inlet line; a tank can be inserted in the circuit to vary the system volume.

The on-board PLC includes a PID algorithm block and is able to manage the unit through an Ethernet communications module. This module allows the PLC to work together with an operator panel for the information exchange. The panel has several graphic pages, with the unit synoptic diagram, the open and closed control loop main parameters, and the graphic of the system response according to the working situations.

### TRAINING PROGRAM:

This unit enables to develop and analyze the following subjects:

- Proportional, Integral and Derivative control
- Open-loop control
- Closed-loop control
- Tuning a controller
- Response to a noise

### TECHNICAL SPECIFICATIONS:

- Framework of AISI 304 stainless steel
- Pneumatic control valve of AISI 316 stainless steel, Cv = 2.5
- Electronic pressure transmitter of stainless steel with range of 0 to 6 bar
- Bourdon gauge of stainless steel with range of 0 to 6 bar
- Electro-pneumatic converter, 4 to 20 mA / 0.2 to 1 bar
- Piping and valves of AISI 304 and 316 stainless steel
- Pressure gauge for measuring the output signal of I/P converter
- Switchboard of painted carbon steel with synoptic, ELCB and measuring terminals for input and output signals of the controller
- This unit can be connected with module mod. FCBp/EV, for the simultaneous control of pressure and flow rate
- Pipes and valves of AISI 304 and 316 stainless steel



- Industrial PLC placed in the electrical board, including the PID control block and Ethernet communications module. It is included the standard IEC 1131 61131 programming software.
- Operator Panel, 7" TFT touchscreen display, 16 million colors, 800 x 480 pixels, with RJ45 PROFINET ports; the H.M.I (Human Machine Interface) industrial supervision software is included.

**Power Supply:** 230 Vac 50 Hz single-phase - 0,5 kVA  
(Other voltage and frequency on request)

**Dimensions:** 850 x 600 x 750 mm

**Net Weight:** 50 kg

Examples of the operator panel graphic pages:

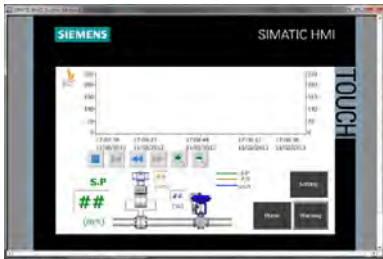
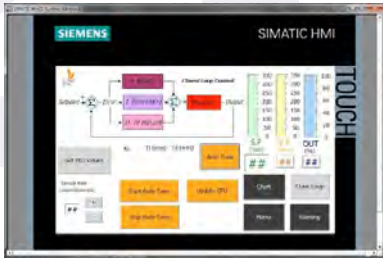

**REQUIRED**

**UTILITIES (PROVIDED BY THE CUSTOMER)**

- Compressed air (2 female valves of 1/4"): 0.3 Nm<sup>3</sup>/h @ 1.5 bar, and 25 Nm<sup>3</sup>/h @ 6 bar

**ACCESSORIES (NOT INCLUDED)**

- Personal Computer running Windows 7 Professional (32 bit)

**SUPPLIED WITH**

**THEORETICAL-EXPERIMENTAL HANDBOOK**



**OPTIONAL**

**TWO-PEN RECORDER**

(it must be installed before shipment, not as upgrade)

# TEMPERATURE CONTROL

## Mod. TCBp/EV (PLC on-board)

This bench top unit enables to carry out several tests of temperature control on a closed circuit for hot water.

A centrifugal pump makes the hot water recirculate from a heating tank to a plate-type exchanger cooled by tap water. Temperature is measured by a thermoresistance and it is controlled by a pneumatic valve inserted in the inlet line of cold water.

The on-board PLC includes a PID algorithm block and is able to manage the unit through an Ethernet communications module. This module allows the PLC to work together with an operator panel for the information exchange. The panel has several graphic pages, with the unit synoptic diagram, the open and closed control loop main parameters, and the graphic of the system response according to the working situations.



### TRAINING PROGRAM:

This unit enables to develop and analyze the following subjects:

- Proportional, Integral and Derivative control
- Open-loop control
- Closed-loop control
- Tuning a controller
- Response to a noise

### TECHNICAL SPECIFICATIONS:

- Framework of AISI 304 stainless steel
- Pneumatic control valve of AISI 316 stainless steel,  $C_v = 0.13$
- Electro-pneumatic converter, 4 to 20 mA / 0.2 to 1 bar
- Hot water generator with tank of AISI 304 stainless steel, electric heating system, recirculation pump of AISI 304 stainless steel and thermostat
- Pressure gauge for measuring the output signal of I/P converter
- Switchboard of painted carbon steel with synoptic, ELCB and measuring terminals for input and output signals of the controller
- Pipes and valves of AISI 304 and 316 stainless steel

- Industrial PLC placed in the electrical board, including the PID control block and Ethernet communications module. It is included the standard IEC 1131 61131 programming software.
- Operator Panel, 7" TFT touchscreen display, 16 million colors, 800 x 480 pixels, with RJ45 PROFINET ports; the H.M.I (Human Machine Interface) industrial supervision software is included.

**Power Supply:** 230 Vac 50 Hz single-phase - 3,5 kVA  
(Other voltage and frequency on request)

**Dimensions:** 850 x 600 x 750 mm

**Net Weight:** 50 kg



Examples of the operator panel graphic pages:

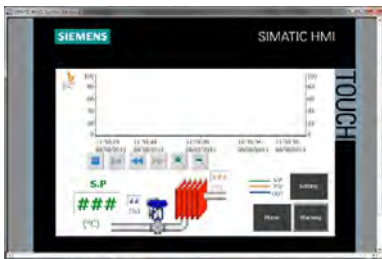
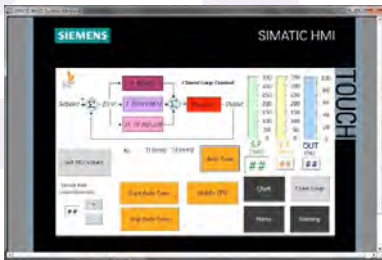
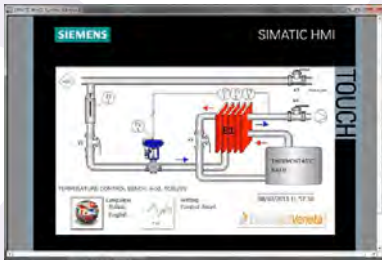

The complete system: temperature control unit and hot water generator



**REQUIRED**

**UTILITIES (PROVIDED BY THE CUSTOMER)**

- Tap water (valve with 1/2" hose connector): 1000 l/h @ 2 bar
- Compressed air (female valve of 1/4"): 0,3 Nm<sup>3</sup>/h @ 1,5 bar

**ACCESSORIES (NOT INCLUDED)**

- Personal Computer running Windows 7 Professional (32 bit)

**SUPPLIED WITH**

**THEORETICAL-EXPERIMENTAL HANDBOOK**



**OPTIONAL**

**TWO-PEN RECORDER**

(it must be installed before shipment, not as upgrade)

# pH CONTROL

## Mod. pHCBp/EV (PLC on-board)

This bench top unit consists of a stirred reactor that is fed with an acid solution by a metering pump. Controlling the flow rate of another metering pump that sends basic solution into the reactor will enable to control the pH inside the reactor.

The on-board PLC includes a PID algorithm block and is able to manage the unit through an Ethernet communications module. This module allows the PLC to work together with an operator panel for the information exchange. The panel has several graphic pages, with the unit synoptic diagram, the open and closed control loop main parameters, and the graphic of the system response according to the working situations.

### TRAINING PROGRAM:

This unit enables to develop and analyze the following subjects:

- Proportional, Integral and Derivative control
- Setup of controllers
- Response and characteristics of the process
- Determining dead time
- Tuning the controller
- Calibrating a pH-meter

### TECHNICAL SPECIFICATIONS:

- Framework of AISI 304 stainless steel
- pH transmitter with range of 0-14 pH and 4-20 mA output
- 2 metering pumps with 4-20 mA input
- 2 tanks of AISI 316 stainless steel with capacity of 13 litres
- Tank of AISI 316 stainless steel with capacity of 26 litres
- Reactor of AISI 316 stainless steel with variable-speed (0-600 rpm) stirrer and capacity of 3 litres
- Piping and valves of AISI 316 stainless steel
- Switchboard of painted carbon steel with synoptic, ELCB and measuring terminals for input and output signals of the controller
- Industrial PLC placed in the electrical board, including the PID control block and Ethernet communications module. It is included the standard IEC 1131 61131 programming software.



- Operator Panel, 7" TFT touchscreen display, 16 million colors, 800 x 480 pixels, with RJ45 PROFINET ports; the H.M.I (Human Machine Interface) industrial supervision software is included.

**Power Supply:** 230 Vac 50 Hz single-phase - 0.5 kVA  
(Other voltage and frequency on request)

**Dimensions:** 850 x 600 x 750 mm

**Net Weight:** 50 kg

Examples of the operator panel graphic pages:

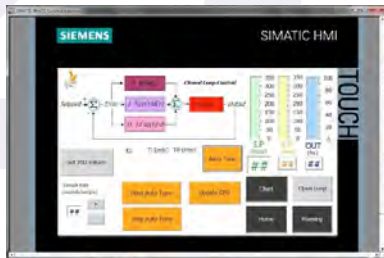

**REQUIRED**

**UTILITIES (PROVIDED BY THE CUSTOMER)**

- Compressed air (female valve of 1/4"): 4 Nm<sup>3</sup>/h @ 6 bar max.
- Tap water (valve with 1/2" hose connector): 1000 l/h @ 2 bar max.
- Water drain

**ACCESSORIES (NOT INCLUDED)**

- Personal Computer running Windows 7 Professional (32 bit)

**SUPPLIED WITH**

**THEORETICAL-EXPERIMENTAL HANDBOOK**



**OPTIONAL**

**TWO-PEN RECORDER**

(it must be installed before shipment, not as upgrade)





# 26-D



ME

## MECHATRONICS

 ME  
[www.elettronicaveneta.com](http://www.elettronicaveneta.com)

### **Aim:**

- Studying and managing industrial plants of high automation; choosing and developing machining and assembling cycles and the most suitable industrial processes.

### **Equipment:**

- Mechatronics modules simulating single processes (manipulation, spinning, storage, etc.).
- Working cells and automated production lines simulating a complete machining of a workpiece

26D-E-ME



# 26-b



ME

AUTOMATION TECHNOLOGIES

www.elettronicaveneta.com

26D-E-ME

## MECHATRONICS

	<b>MODULES</b>	ME 4
	<b>WORKING CELLS &amp; AUTOMATED PRODUCTION LINES</b>	ME 23
	<b>BASIC LINE</b>	ME 31

# 26-D



## MODULES

<b>PIECE IDENTIFICATION AND DISTRIBUTION MODULE</b>	Mod. MCS-500/EV	ME 5
<b>PIECES DISTRIBUTION MODULE</b>	Mod. MCS-505/EV	ME 6
<b>SWIVEL ARM AND MANIPULATOR MODULE</b>	Mod. MCS-510/EV	ME 7
<b>PIECES THICKNESS MEASUREMENT MODULE</b>	Mod. MCS-520/EV	ME 8
<b>LINEAR STORAGE MODULE</b>	Mod. MCS-530/EV	ME 9
<b>ROTARY INDEXING TABLE MODULE</b>	Mod. MCS-570/EV	ME 10
<b>ELECTRIC PICK AND PLACE MODULE</b>	Mod. MCS-580/EV	ME 11
<b>PNEUMATIC ARM MODULE</b>	Mod. MCS-590/EV	ME 12
<b>DRILLING STATION MODULE</b>	Mod. MCS-600/EV	ME 13
<b>ROTATING STORAGE MODULE</b>	Mod. MCS-610/EV	ME 14
<b>CARTESIAN CONTROL STORAGE MODULE</b>	Mod. MCS-620/EV	ME 15
<b>CONVEYOR MODULE</b>	Mod. MCS-700/EV	ME 16
<b>ROBOT MODULE</b>	Mod. MCS-710/EV	ME 17
<b>MODULE FOR TESTING AND SELECTING PIECES</b>	Mod. MCS-720/EV	ME 18
<b>WEIGHING MODULE</b>	Mod. MCS-730/EV	ME 19
<b>STORAGE MODULE FOR PRISMATIC PIECES</b>	Mod. MCS-740/EV	ME 20
<b>BOX OF TOOLS AND WORKPIECES</b>	Mod. ATZ/EV	ME 21
<b>AIR SERVICE UNIT</b>	Mod. SRA/EV	ME 21
<b>PUSHBUTTON PANEL</b>	Mod. PULS/EV	ME 22
<b>SILENCED COMPRESSOR</b>	Mod. 3409A	ME 22

# PIECE IDENTIFICATION AND DISTRIBUTION MODULE

## Mod. MCS-500/EV

The distribution module mod. MCS-500/EV allows the pieces distribution and the material recognition. The pieces are taken from a store and lead to the following working stages. The pieces are cylindrically shaped and are made of different material and color.

The operation starts with a double effect cylinder to expel the piece from the store. A sensor detects the piece presence/absence in the store.

The expelled piece is put in an area equipped with:

- a microswitch
- a optic reflection sensor
- a inductive sensor

The module mod. MCS-500/EV, as a whole, is assembled on a aluminium section bar structure easily transportable inside the laboratory.

The complete control of the module mod. MCS-500/EV is carried out by a PLC (optional) linked to the system through an I/O interface box.

The PLC programming software allows the development of a wide set of automation experiences with the module mod. MCS-500/EV, working in an integrated cycle or in a stand alone mode.

Finally, the module mod. MCS-500EV supervision is carried out with the software mod. SV/EV.

### TRAINING PROGRAM:

The training program that can be developed with the module mod. MCS-500/EV includes:

- Principles of electro-pneumatics
- Operation of a double effect pneumatic cylinder
- Operation of the 5/2 ways electrovalve
- Operation of the magnetic, optic and inductive sensors
- Study of the loading systems
- Study of the PLC module management

### TECHNICAL SPECIFICATIONS:

Modular unit assembled on a aluminium section bar structure. It includes I/O interface box with:

- $\varnothing = 2$  mm terminals
- Cable with 25-pole D-SUB plug connector

Besides performing the function of control board for the module, this interface box also enables the students to carry out electrical measurements on the components of the module.

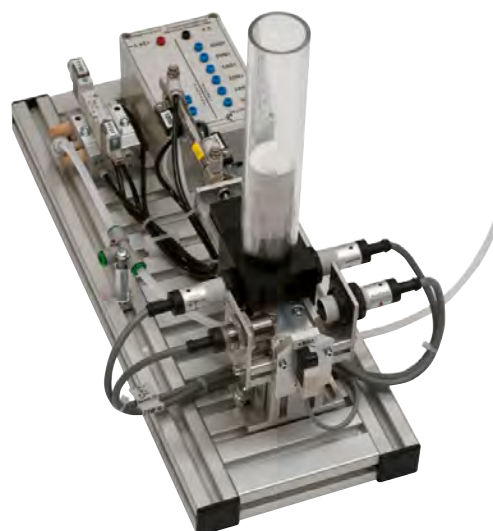

The control of the module is possible through the follow PLC training panels (not supplied):

- PLC training panels mod. PLC-V7/EV or mod. PLC-V8/EV: manages the module through  $\varnothing = 2$  mm terminals.

In case one of these two panels is used, a 24 Vdc power supply is already mounted on board.

Sensors and actuators:

- 2 Optical sensors
- 1 Inductive sensor
- 2 REED sensors
- 1 Micro-switch
- 1 5/2 bistable electrovalve

Station inputs and outputs:

- 6 Digital inputs
- 2 Digital outputs

**Dimensions:** 160 x 400 x 270 mm

**Weight:** 4 kg

### REQUIRED

#### UTILITIES (PROVIDED BY THE CUSTOMER)

- Power supply: 24 Vdc
- Compressed air supply: 5...6 bar

### SUPPLIED WITH

#### THEORETICAL-EXPERIMENTAL HANDBOOK

Presentation of the equipment, experiments, technical specifications with electric and pneumatic diagrams, use and maintenance.



# PIECES DISTRIBUTION MODULE Mod. MCS-505/EV

The distribution module mod. MCS-505/EV allows the distribution of pieces from a store to the subsequent working stations. The cylindrical pieces of different material fall down by gravity on a special support base. A cylinder expels them from the store to an appropriate work area. The presence of the piece in this area is detected by a microswitch. The pieces presence / absence in the cylindrical store is detected by an optical sensor.

The module mod. MCS-505/EV, as a whole, is assembled on a aluminium section bar structure easily transportable inside the laboratory.

The complete control of the module mod. MCS-505/EV is carried out by a PLC (optional) linked to the system through an I/O interface box.

The PLC programming software allows the development of a wide set of automation experiences with the module mod. MCS-505/EV, working in an integrated cycle or in a stand alone mode.

Finally, the module mod. MCS-505/EV supervision is carried out with the software mod. SV/EV.

## TRAINING PROGRAM:

The training program that can be developed with the module mod. MCS-505/EV includes:

- Principles of electro-pneumatics
- Operation of the double effect pneumatic cylinder
- Operation of a 5/2 ways bistable electrovalve
- Study of the positioning systems

## TECHNICAL SPECIFICATIONS:

Modular unit assembled on a aluminium section bar structure. It includes I/O interface box with:

- $\varnothing = 2$  mm terminals
- Cable with 25-pole D-SUB plug connector

Besides performing the function of control board for the module, this interface box also enables the students to carry out electrical measurements on the components of the module.



The control of the module is possible through the follow PLC training panels (not supplied):

- PLC training panels mod. PLC-V7/EV or mod. PLC-V8/EV: manages the module through  $\varnothing = 2$  mm terminals.

In case one of these two panels is used, a 24 Vdc power supply is already mounted on board.

Sensors and actuators:

- 1 Micro-switch
- 2 REED sensors
- 1 Optical sensor
- 1 5/2 bistable electrovalve

Station inputs and outputs:

- 4 Digital inputs
- 2 Digital outputs

**Dimensions:** 160 x 400 x 270 mm

**Weight:** 3 kg

## REQUIRED

### UTILITIES (PROVIDED BY THE CUSTOMER)

- Power supply: 24 Vdc
- Compressed air supply: 5...6 bar

## SUPPLIED WITH

### THEORETICAL-EXPERIMENTAL HANDBOOK

Presentation of the equipment, experiments, technical specifications with electric and pneumatic diagrams, use and maintenance.



# SWIVEL ARM AND MANIPULATOR MODULE

## Mod. MCS-510/EV

The module mod. MCS-510/EV carries out the pieces transportation from a station to another one. It is constituted by a rotary pneumatic cylinder adjustable inside an 180° angle. The pieces transportation is performed by a vacuum suction cap system controlled by an electrovalve.

The cylinder limit switches are REED-type and the movement is controlled by a 5/2 way electrovalve.

The module mod. MCS-510/EV, as a whole, is assembled on a aluminium section bar structure easily transportable inside the laboratory.

The complete control of the module mod. MCS-510/EV is carried out by a PLC (optional) linked to the system through an I/O interface box.

The PLC programming software allows the development of a wide set of automation experiences with the module mod. MCS-510/EV, working in an integrated cycle or in a stand alone mode.

Finally, the module mod. MCS-510/EV supervision is carried out with the software mod. SV/EV.

### TRAINING PROGRAM:

The training program that can be developed with the distribution station mod. MCS-510/EV, includes:

- Principles of electro-pneumatics
- Operation of a rotative pneumatic cylinder
- Study of the "Pick & Place" unit supplied with suction cup
- Operation of a 5/3 ways solenoid electrovalve
- Study of the "REED" sensors
- Study of the electro-pneumatic positioning systems
- Study of the safety

### TECHNICAL SPECIFICATIONS:

Modular unit assembled on a aluminium section bar structure. It includes I/O interface box with:

- Ø = 2 mm terminals
- Cable with 25-pole D-SUB plug connector

Besides performing the function of control board for the module, this interface box also enables the students to carry out electrical measurements on the components of the module.



The control of the module is possible through the follow PLC training panels (not supplied):

- PLC training panels mod. PLC-V7/EV or mod. PLC-V8/EV: manages the module through Ø = 2 mm terminals.

In case one of these two panels is used, a 24 Vdc power supply is already mounted on board.

Sensors and actuators:

- 2 REED sensors
- 1 3/2 monostable electrovalve
- 1 5/2 bistable electrovalve

Station inputs and outputs:

- 2 Digital inputs
- 3 Digital outputs

**Dimensions:** 160 x 400 x 270 mm

**Weight:** 4 kg

### REQUIRED

#### UTILITIES (PROVIDED BY THE CUSTOMER)

- Power supply: 24 Vdc
- Compressed air supply: 5...6 bar

### SUPPLIED WITH

#### THEORETICAL-EXPERIMENTAL HANDBOOK

Presentation of the equipment, experiments, technical specifications with electric and pneumatic diagrams, use and maintenance.





# PIECES THICKNESS MEASUREMENT MODULE Mod. MCS-520/EV

The measurement module mod. MCS-520/EV allows to discriminate the pieces depending on their thickness. The measurement is carried out by a sensor whose output voltage is an analog signal between 0-10 V. The piece is lead up by a trolley and pushed against the sensor in order to determine the thickness. The result of the test is then applied during the descent of the trolley. When the piece fits the pre-set parameters, it is released in the first slide, otherwise it is "rejected" and discharged in the second slide.

The module mod. MCS-520/EV, as a whole, is assembled on a aluminium section bar structure easily transportable inside the laboratory.

The complete control of the module mod. MCS-520/EV is carried out by a PLC (optional) linked to the system through an I/O interface box.

The PLC programming software allows the development of a wide set of automation experiences with the module mod. MCS-520/EV, working in an integrated cycle or in a stand alone mode.

Finally, the module mod. MCS-520/EV supervision is carried out with the software mod. SV/EV.

## TRAINING PROGRAM:

The training program that can be developed with the module mod. MCS-520/EV, includes:

- Principles of electro-pneumatics
- Study of piece selection methods
- Operation of the electrovalves
- Operation of the "REED" sensors
- Operation of a double effect cylinder
- Operation of a no stem cylinder

## TECHNICAL SPECIFICATIONS:

Modular unit assembled on a aluminium section bar structure. It includes I/O interface box with:

- $\varnothing = 2$  mm terminals
- Cable with 25-pole D-SUB plug connector

Besides performing the function of control board for the module, this interface box also enables the students to carry out electrical measurements on the components of the module.

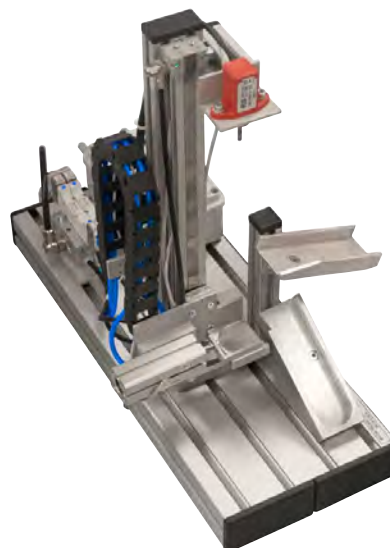

The control of the module is possible through the follow PLC training panels (not supplied):

- PLC training panels mod. PLC-V7/EV or mod. PLC-V8/EV: manages the module through  $\varnothing = 2$  mm terminals.

In case one of these two panels is used, a 24 Vdc power supply is already mounted on board.

Sensors and actuators:

- 1 Linear potentiometer sensor
- 3 REED sensors
- 1 5/2 monostable electrovalve
- 1 5/3 electrovalve

Station inputs and outputs:

- 4 Digital inputs
- 3 Digital outputs
- 1 Analogic outputs

**Dimensions:** 160 x 400 x 270 mm

**Weight:** 4.4 kg

## REQUIRED

### UTILITIES (PROVIDED BY THE CUSTOMER)

- Power supply: 24 Vdc
- Compressed air supply: 5...6 bar

## SUPPLIED WITH

### THEORETICAL-EXPERIMENTAL HANDBOOK

Presentation of the equipment, experiments, technical specifications with electric and pneumatic diagrams, use and maintenance.



# LINEAR STORAGE MODULE Mod. MCS-530/EV

The module mod. MCS-530/EV enables to store pieces according to the type of material of their composition. Pieces are conveyed by a carriage shifting linearly along an axis and stopping to fill the chutes according to the tests carried out in the previous stations. A cylinder will throw the piece from the carriage into the assigned chute. The condition of full chute, as well as the position of the carriage is identified by some optical sensors.

The module mod. MCS-530/EV is wholly assembled on a structure of aluminium profile that can easily be moved inside a laboratory.

The complete control of the module mod. MCS-530/EV is carried out by a PLC (optional) linked to the system through an I/O interface box.

The PLC programming software allows the development of a wide set of automation experiences with the module mod. MCS-530/EV, working in an integrated cycle or in a stand alone mode.

Finally, the module mod. MCS-530/EV supervision is carried out with the software mod. SV/EV.

## TRAINING PROGRAM:

The training program that can be developed with the module mod. MCS-530/EV, includes:

- Principles of electro-pneumatics
- Study of piece storing methods
- Operation of the electrovalves
- Operation of the "REED" sensors
- Operation of a motor of 24 Vdc

## TECHNICAL SPECIFICATIONS:

Modular unit assembled on a aluminium section bar structure. It includes I/O interface box with:

- $\varnothing = 2$  mm terminals
- Cable with 25-pole D-SUB plug connector

Besides performing the function of control board for the module, this interface box also enables the students to carry out electrical measurements on the components of the module.

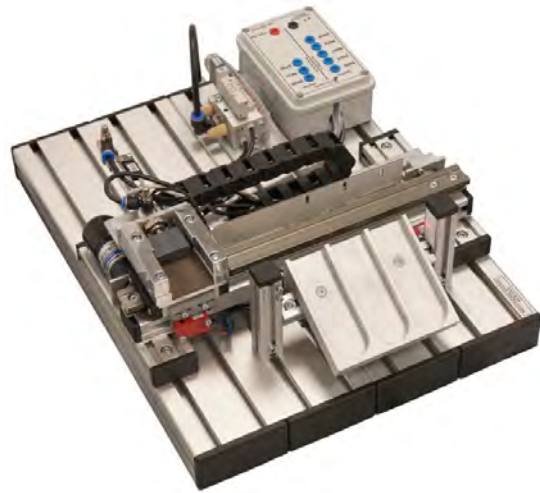

The control of the module is possible through the follow PLC training panels (not supplied):

- PLC training panels mod. PLC-V7/EV or mod. PLC-V8/EV: manages the module through  $\varnothing = 2$  mm terminals.

In case one of these two panels is used, a 24 Vdc power supply is already mounted on board.

Sensors and actuators:

- 1 U-type optical sensor
- 2 REED sensors
- 2 Micro-switch
- 1 5/2 monostable electrovalve
- 1 DC motor 24 Vdc

Station inputs and outputs:

- 6 Digital inputs
- 3 Digital outputs

**Dimensions:** 320 x 400 x 270 mm

**Weight:** 4.4 kg

## REQUIRED

### UTILITIES (PROVIDED BY THE CUSTOMER)

- Power supply: 24 Vdc
- Compressed air supply: 5...6 bar

## SUPPLIED WITH

### THEORETICAL-EXPERIMENTAL HANDBOOK

Presentation of the equipment, experiments, technical specifications with electric and pneumatic diagrams, use and maintenance.



# ROTARY INDEXING TABLE MODULE Mod. MCS-570/EV

The module mod. MCS-570/EV includes a rotary table where the pieces to be examined are placed. A set of three sensors: capacitive, inductive and optical determines the presence and the material type of the piece.

The positions of the rotary table are controlled by a proximity sensor, while the rotation is managed by a little DC motor. There are two free positions for picking up and put down the pieces.

The module mod. MCS-570/EV, as a whole, is assembled on a aluminium section bar structure easily transportable inside the laboratory.

The complete control of the module mod. MCS-570/EV is carried out by a PLC (optional) linked to the system through an I/O interface box.

The PLC programming software allows the development of a wide set of automation experiences with the module mod. MCS-570/EV, working in an integrated cycle or in a stand alone mode.

Finally, the module mod. MCS-570/EV supervision is carried out with the software mod. SV/EV.

## TRAINING PROGRAM:

The training program that can be developed with the module mod. MCS-570/EV, includes:

- Principles of electro-pneumatics
- Study of the pieces identification systems
- Study of the sensors.
- Study of the DC motors

## TECHNICAL SPECIFICATIONS:

Modular unit assembled on a aluminium section bar structure. It includes I/O interface box with:

- $\varnothing = 2$  mm terminals
- Cable with 25-pole D-SUB plug connector

Besides performing the function of control board for the module, this interface box also enables the students to carry out electrical measurements on the components of the module.



The control of the module is possible through the follow PLC training panels (not supplied):

- PLC training panels mod. PLC-V7/EV or mod. PLC-V8/EV: manages the module through  $\varnothing = 2$  mm terminals.

In case one of these two panels is used, a 24 Vdc power supply is already mounted on board.

Sensors and actuators:

- 1 Optical sensor
- 1 Capacitive sensor
- 2 Inductive sensors
- 1 DC motor 24 Vdc

Station inputs and outputs:

- 4 Digital inputs
- 4 Digital outputs

**Dimensions:** 320 x 400 x 300 mm

**Weight:** 6 kg

## REQUIRED

### UTILITIES (PROVIDED BY THE CUSTOMER)

- Power supply: 24 Vdc

## SUPPLIED WITH

### THEORETICAL-EXPERIMENTAL HANDBOOK

Presentation of the equipment, experiments, technical specifications with electric and pneumatic diagrams, use and maintenance.



# ELECTRIC PICK AND PLACE MODULE

## Mod. MCS-580/EV

The module mod. MCS-580/EV performs the pieces transportation from one station to another one. The movement is carried out with a rotary arm with a suction cap. Three micro-switch detect the correct position for the pieces loading / unloading, while a sensor placed on a cylinder, controls the limit switches during the high / low movement. The cylinder movement and the vacuum system for the suction cap are controlled by electro-valves.

The module mod. MCS-580/EV, as a whole, is assembled on a aluminium section bar structure easily transportable inside the laboratory.

The complete control of the module mod. MCS-580/EV is carried out by a PLC (optional) linked to the system through an I/O interface box.

The PLC programming software allows the development of a wide set of automation experiences with the module mod. MCS-580/EV, working in an integrated cycle or in a stand alone mode.

Finally, the module mod. MCS-580/EV supervision is carried out with the software mod. SV/EV.

### TRAINING PROGRAM:

The training program that can be developed with the module mod. MCS-580/EV, includes:

- Principles of electro-pneumatics
- Solutions for piece transportation
- Study of the vacuum technologies
- Operation of electro-valves
- Operation of the sensors

### TECHNICAL SPECIFICATIONS:

Modular unit assembled on a aluminium section bar structure. It includes I/O interface box with:

- $\varnothing = 2$  mm terminals
- Cable with 25-pole D-SUB plug connector

Besides performing the function of control board for the module, this interface box also enables the students to carry out electrical measurements on the components of the module.

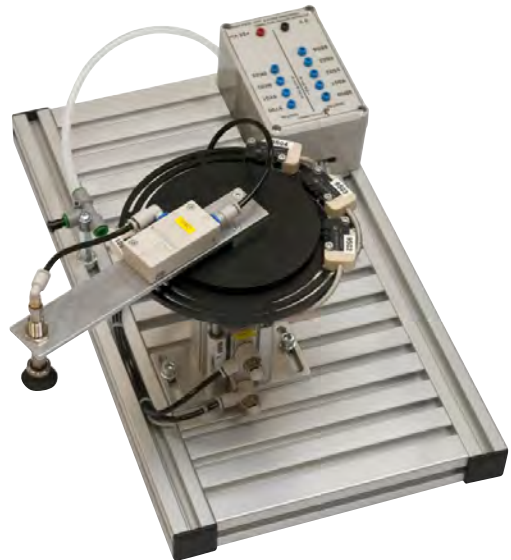

The control of the module is possible through the follow PLC training panels (not supplied):

- PLC training panels mod. PLC-V7/EV or mod. PLC-V8/EV: manages the module through  $\varnothing = 2$  mm terminals.

In case one of these two panels is used, a 24 Vdc power supply is already mounted on board.

Sensors and actuators:

- 4 Micro-switch
- 1 Magnetic sensor
- 1 DC motor 24 Vdc
- 1 5/2 monostable electrovalve
- 1 3/2 monostable electrovalve
- 1 Vacuum generator

Station inputs and outputs:

- 6 Digital inputs
- 4 Digital outputs

**Dimensions:** 160 x 400 x 150 mm

**Weight:** 3.7 kg

### REQUIRED

#### UTILITIES (PROVIDED BY THE CUSTOMER)

- Power supply: 24 Vdc

### SUPPLIED WITH

#### THEORETICAL-EXPERIMENTAL HANDBOOK

Presentation of the equipment, experiments, technical specifications with electric and pneumatic diagrams, use and maintenance.

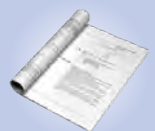

# PNEUMATIC ARM MODULE Mod. MCS-590/EV

The module mod. MCS-590/EV fulfils the pieces transportation from one station to another. It is constituted by a manipulator with a double effect cylinder for the high/low movement, a rotating cylinder for the piece transportation from one position to another and a pneumatic gripper for picking up the piece. The movements of the pneumatic devices are controlled by sensors.

The complete control of the module mod. MCS-590/EV is carried out by a PLC (optional) linked to the system through an I/O interface box.

The PLC programming software allows the development of a wide set of automation experiences with the module mod. MCS-590/EV, working in an integrated cycle or in a stand alone mode.

Finally, the module mod. MCS-590/EV supervision is carried out with the software mod. SV/EV.

## TRAINING PROGRAM:

The training program that can be developed with the module mod. MCS-590/EV includes:

- Principles of electro-pneumatics
- Operation of the pneumatic cylinders
- Operation of the pneumatic gripper
- Operation of solenoid electro-valves
- Operation of the magnetic sensors

## TECHNICAL SPECIFICATIONS:

Modular unit assembled on a aluminium section bar structure. It includes I/O interface box with:

- $\varnothing = 2$  mm terminals
- Cable with 25-pole D-SUB plug connector

Besides performing the function of control board for the module, this interface box also enables the students to carry out electrical measurements on the components of the module.



The control of the module is possible through the follow PLC training panels (not supplied):

- PLC training panels mod. PLC-V7/EV or mod. PLC-V8/EV: manages the module through  $\varnothing = 2$  mm terminals.

In case one of these two panels is used, a 24 Vdc power supply is already mounted on board.

Sensors and actuators:

- 3 REED sensors
- 1 Inductive sensor
- 2 5/2 monostable electro-valves
- 1 5/2 bistable electrovalve

Station inputs and outputs:

- 4 Digital inputs
- 4 Digital outputs

**Dimensions:** 160 x 400 x 250 mm

**Weight:** 3.2 kg

## REQUIRED

### UTILITIES (PROVIDED BY THE CUSTOMER)

- Power supply: 24 Vdc
- Compressed air supply: 5...6 bar

## SUPPLIED WITH

### THEORETICAL-EXPERIMENTAL HANDBOOK

Presentation of the equipment, experiments, technical specifications with electric and pneumatic diagrams, use and maintenance.





# DRILLING STATION MODULE Mod. MCS-600/EV

The module mod. MCS-600/EV is a piece drilling station. It is constituted by a column mini drill where the high/low movement is carried out by a pneumatic skid to which the drill is hooked. The piece to be drilled is put on a base moved by a piston.

During the piece reception phase, the base is pushed outside, while during the drilling phase it is withdrawn in the position under the drill.

The module mod. MCS-600/EV, as a whole, is assembled on a aluminium section bar structure easily transportable inside the laboratory.

The complete control of the module mod. MCS-600/EV is carried out by a PLC (optional) linked to the system through an I/O interface box.

The PLC programming software allows the development of a wide set of automation experiences with the module mod. MCS-600/EV, working in an integrated cycle or in a stand alone mode.

Finally, the module mod. MCS-600/EV supervision is carried out with the software mod. SV/EV.

## TRAINING PROGRAM:

The training program that can be developed with the module mod. MCS-600/EV includes:

- Principles of electro-pneumatics
- Study of the drilling systems
- Study of the sensors

## TECHNICAL SPECIFICATIONS:

Modular unit assembled on a aluminium section bar structure. It includes I/O interface box with:

- $\varnothing = 2$  mm terminals
- Cable with 25-pole D-SUB plug connector

Besides performing the function of control board for the module, this interface box also enables the students to carry out electrical measurements on the components of the module.



The control of the module is possible through the follow PLC training panels (not supplied):

- PLC training panels mod. PLC-V7/EV or mod. PLC-V8/EV: manages the module through  $\varnothing = 2$  mm terminals.

In case one of these two panels is used, a 24 Vdc power supply is already mounted on board.

Sensors and actuators:

- 1 DC motor 24 Vdc
- 4 REED sensors
- 1 5/2 monostable electrovalve
- 1 5/2 bistable electrovalve

Station inputs and outputs:

- 4 Digital inputs
- 4 Digital outputs

**Dimensions:** 160 x 400 x 400 mm

**Weight:** 4.5 kg

## REQUIRED

### UTILITIES (PROVIDED BY THE CUSTOMER)

- Power supply: 24 Vdc
- Compressed air supply: 5...6 bar

## SUPPLIED WITH

### THEORETICAL-EXPERIMENTAL HANDBOOK

Presentation of the equipment, experiments, technical specifications with electric and pneumatic diagrams, use and maintenance.



# ROTATING STORAGE MODULE Mod. MCS-610/EV

The module mod. MCS-610/EV allows to store the pieces in three different positions. The pieces movement is carried out by a rotative system with a suction cap. The pieces are then moved among the three preset transparent cylinders for unloading. Four microswitches set the right position for the pieces loading/unloading, while a sensor on the pneumatic cylinder checks the stroke. The cylinder movement and the vacuum required by the suction cap are controlled by electro-valves.

The module mod. MCS-610/EV, as a whole, is assembled on a aluminium section bar structure easily transportable inside the laboratory.

The complete control of the module mod. MCS-610/EV is carried out by a PLC (optional) linked to the system through an I/O interface box.

The PLC programming software allows the development of a wide set of automation experiences with the module mod. MCS-610/EV, working in an integrated cycle or in a stand alone mode.

Finally, the module mod. MCS-610/EV supervision is carried out with the software mod. SV/EV.

## TRAINING PROGRAM:

The training program that can be developed with the module mod. MCS-610/EV includes:

- Principles of electro-pneumatics
- Study of the storage systems
- Operation of the sensors
- Operation of the electrovalves

## TECHNICAL SPECIFICATIONS:

Modular unit assembled on a aluminium section bar structure. It includes I/O interface box with:

- $\varnothing = 2$  mm terminals
- Cable with 25-pole D-SUB plug connector

Besides performing the function of control board for the module, this interface box also enables the students to carry out electrical measurements on the components of the module.



The control of the module is possible through the follow PLC training panels (not supplied):

- PLC training panels mod. PLC-V7/EV or mod. PLC-V8/EV: manages the module through  $\varnothing = 2$  mm terminals.

In case one of these two panels is used, a 24 Vdc power supply is already mounted on board.

Sensors and actuators:

- 4 Micro switches
- 1 REED sensor
- 1 DC motor 24 Vdc
- 2 5/2 monostable electro-valves

Station inputs and outputs:

- 5 Digital inputs
- 4 Digital outputs

**Dimensions:** 320 x 400 x 150 mm

**Weight:** 4.5 kg

## REQUIRED

### UTILITIES (PROVIDED BY THE CUSTOMER)

- Power supply: 24 Vdc
- Compressed air supply: 5...6 bar

## SUPPLIED WITH

### THEORETICAL-EXPERIMENTAL HANDBOOK

Presentation of the equipment, experiments, technical specifications with electric and pneumatic diagrams, use and maintenance.



# CARTESIAN CONTROL STORAGE MODULE Mod. MCS-620/EV

The module mod. MCS-620/EV allows to store the pieces according with the material they are made of. The movement is carried out through a three axes Cartesian controlled system and allows to pick up or put down the pieces on three different levels. The store presents twelve positions, four for each level. A sensor positioned on the gripper allows a first inspection of the store, in order to determine the free and occupied positions. Two DC motors carry out the translations along the X and Y axes while a cylinder coupled to the gripping system deals with the movement along the Z axis. The module can be used contemporaneously either as a store for rough or finished pieces.

The module mod. MCS-620/EV, as a whole, is assembled on a aluminium section bar structure easily transportable inside the laboratory.

The complete control of the module mod. MCS-620/EV is carried out by a PLC (optional) linked to the system through an I/O interface box.

The PLC programming software allows the development of a wide set of automation experiences with the module mod. MCS-620/EV, working in an integrated cycle or in a stand alone mode.

Finally, the module mod. MCS-620/EV supervision is carried out with the software mod. SV/EV.

## TRAINING PROGRAM:

The training program that can be developed with the module mod. MCS-620/EV, includes:

- Queues theory
- Electropneumatic circuits
- Electrovalves control
- Cartesian controls
- DC motors
- Sensors performance

## TECHNICAL SPECIFICATIONS:

Modular unit assembled on a aluminium section bar structure. It includes I/O interface box with:

- $\varnothing = 2$  mm terminals
- Cable with 25-pole D-SUB plug connector

Besides performing the function of control board for the module, this interface box also enables the students to carry out electrical measurements on the components of the module.



The control of the module is possible through the follow PLC training panels (not supplied):

- PLC training panels mod. PLC-V7/EV or mod. PLC-V8/EV: manages the module through  $\varnothing = 2$  mm terminals.

In case one of these two panels is used, a 24 Vdc power supply is already mounted on board.

Sensors and actuators:

- 4 Micro switches
- 1 Reflective optical sensor
- 2 U-type optical sensors
- 2 DC motors 24 Vdc
- 1 5/2 monostable electrovalve
- 2 REED sensors

Station inputs and outputs:

- 11 Digital inputs
- 5 Digital outputs

**Dimensions:** 320 x 400 x 320 mm

**Weight:** 9 kg

## REQUIRED

### UTILITIES (PROVIDED BY THE CUSTOMER)

- Power supply: 24 Vdc
- Compressed air supply: 5...6 bar

## SUPPLIED WITH

### THEORETICAL-EXPERIMENTAL HANDBOOK

Presentation of the equipment, experiments, technical specifications with electric and pneumatic diagrams, use and maintenance.



# CONVEYOR MODULE Mod. MCS-700/EV

The module mod. MCS-700/EV has been designed to enable the linear pieces transportation along one axis, in the two directions.

The conveyor is driven by a bi-directional dc motor, controlled by relays that provides the movement of the belt.

A fiber optic sensor detects the work piece on the conveyor belt.

The module mod. MCS-700/EV, as a whole, is assembled on a aluminium section bar structure easily transportable inside the laboratory.

The complete control of the module mod. MCS-700/EV is carried out by a PLC (optional) linked to the system through an I/O interface box.

The PLC programming software allows the development of a wide set of automation experiences with the module mod. MCS-700/EV, working in an integrated cycle or in a stand alone mode.

Finally, the module mod. MCS-700/EV supervision is carried out with the software mod. SV/EV.

## TRAINING PROGRAM:

The training program that can be developed with the module mod. MCS-700/EV includes:

- Principles of electrical control: the DC motor
- The conveyor operation
- The fiber optical sensor

## TECHNICAL SPECIFICATIONS:

Modular unit assembled on a aluminium section bar structure. It includes I/O interface box with:

- $\varnothing = 2$  mm terminals
- Cable with 25-pole D-SUB plug connector

Besides performing the function of control board for the module, this interface box also enables the students to carry out electrical measurements on the components of the module.

The control of the module is possible through the follow PLC training panels (not supplied):

- PLC training panels mod. PLC-V7/EV or mod. PLC-V8/EV: manages the module through  $\varnothing = 2$  mm terminals.

In case one of these two panels is used, a 24 Vdc power supply is already mounted on board.

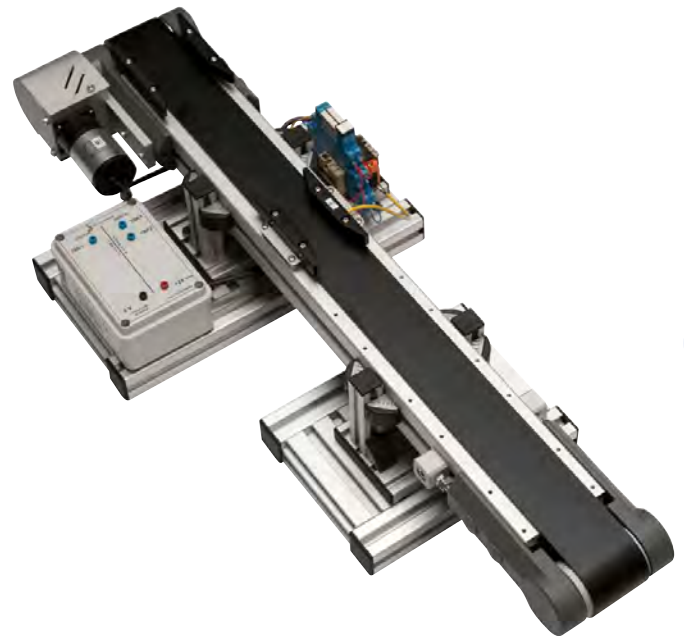

Sensors and actuators:

- 1 Fiber optical sensor
- 1 DC motor 24 Vdc

Station inputs and outputs:

- 1 Digital input
- 2 Digital outputs

**Dimensions:** 680 x 290 x 120 mm

**Weight:** 11 kg

## REQUIRED

### UTILITIES (PROVIDED BY THE CUSTOMER)

- Power supply: 24 Vdc

## SUPPLIED WITH

### THEORETICAL-EXPERIMENTAL HANDBOOK

Presentation of the equipment, experiments, technical specifications with electric and pneumatic diagrams, use and maintenance.



# ROBOT MODULE

## Mod. MCS-710/EV

The robot module mod. MCS-710/EV is used to transport pieces in a circular area. It includes a cylinder for up/down movements, another cylinder for the forward/backward movements, a suction cup for holding the piece, and a motor with encoder coupled to a reducer for the operations of rotation.

The robot's movements are clearly identified by the REED sensors, for the movement of cylinders, and by the inductive sensor for the rotation.

The complete control of the module mod. MCS-710/EV is carried out by a PLC (optional) linked to the system through an I/O interface box.

The PLC programming software allows the development of a wide set of automation experiences with the module mod. MCS-710/EV, working in an integrated cycle or in a stand alone mode.

Finally, the module mod. MCS-710/EV supervision is carried out with the software mod. SV/EV.

### TRAINING PROGRAM:

The training program that can be developed with the module mod. MCS-710/EV includes:

- Principles of electro-pneumatics
- Operation of vacuum circuit coupled to a suction cup
- Operation of the electrovalves
- Operation of REED and inductive sensors

### TECHNICAL SPECIFICATIONS:

Modular unit assembled on a aluminium section bar structure. It includes I/O interface box with:

- $\varnothing = 2$  mm terminals
- Cable with 25-pole D-SUB plug connector

Besides performing the function of control board for the module, this interface box also enables the students to carry out electrical measurements on the components of the module.

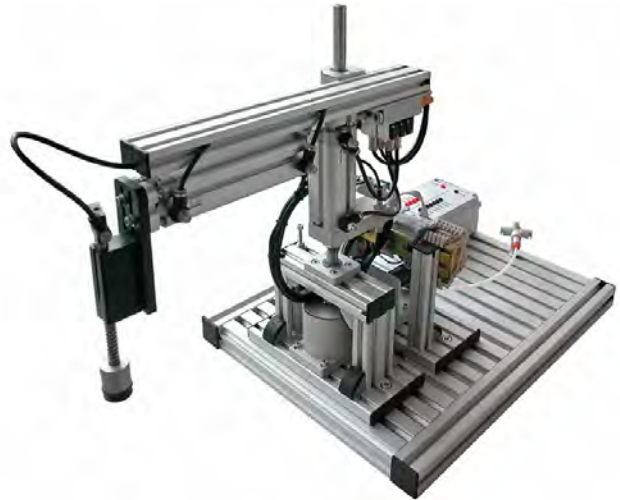

The control of the module is possible through the follow PLC training panels (not supplied):

- PLC training panels mod. PLC-V7/EV or mod. PLC-V8/EV: manages the module through  $\varnothing = 2$  mm terminals.

In case one of these two panels is used, a 24 Vdc power supply is already mounted on board.

Sensors and actuators:

- 4 REED sensors
- 1 Inductive sensor
- 3 5/2 monostable electro-valves
- 1 Motor of 24 Vdc with encoder

Station inputs and outputs:

- 7 Digital inputs
- 5 Digital outputs

**Dimensions:** 190 x 190 x 380 mm

**Weight:** 5 kg

### REQUIRED

#### UTILITIES (PROVIDED BY THE CUSTOMER)

- Power supply: 24 Vdc
- Compressed air supply: 5...6 bar

### SUPPLIED WITH

#### THEORETICAL-EXPERIMENTAL HANDBOOK

Presentation of the equipment, experiments, technical specifications with electric and pneumatic diagrams, use and maintenance.





# MODULE FOR TESTING AND SELECTING PIECES

## Mod. MCS-720/EV

The module mod. MCS-720/EV is used to test and select pieces and it has been designed to work with the module of conveyor belt mod. MCS-700/EV. It consists of two cylinders for the selection of pieces and two sensors: an inductive sensor enables to identify the material (plastic/metal); whereas another optic reflection sensor is used to identify the colour (white/black).

The complete control of the module mod. MCS-720/EV is carried out by a PLC (optional) linked to the system through an I/O interface box.

The PLC programming software allows the development of a wide set of automation experiences with the module mod. MCS-720/EV, working in an integrated cycle or in a stand alone mode.

Finally, the module mod. MCS-720/EV supervision is carried out with the software mod. SV/EV.

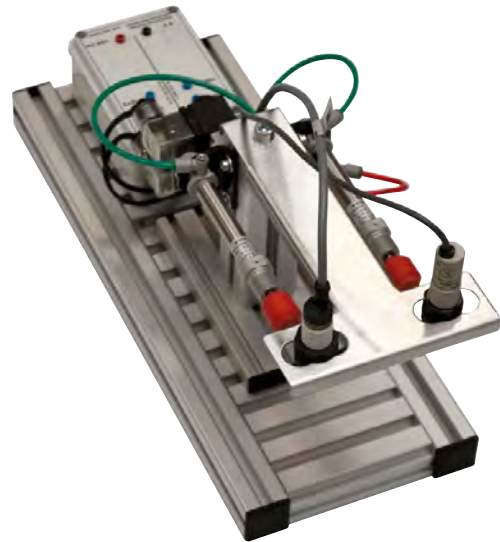

### TRAINING PROGRAM:

The training program that can be developed with the module mod. MCS-720/EV includes:

- Principles of electro-pneumatics
- Operation of pneumatic cylinders
- Operation of inductive sensors
- Operation of optic reflection sensors

### TECHNICAL SPECIFICATIONS:

Modular unit assembled on a aluminium section bar structure. It includes I/O interface box with:

- $\varnothing = 2$  mm terminals
- Cable with 25-pole D-SUB plug connector

Besides performing the function of control board for the module, this interface box also enables the students to carry out electrical measurements on the components of the module.

The control of the module is possible through the follow PLC training panels (not supplied):

- PLC training panels mod. PLC-V7/EV or mod. PLC-V8/EV: manages the module through  $\varnothing = 2$  mm terminals.

In case one of these two panels is used, a 24 Vdc power supply is already mounted on board.

Sensors and actuators:

- 1 Inductive sensor
- 1 Optic reflection sensor
- 2 3/2 electro-valves

Station inputs and outputs:

- 2 Digital inputs
- 2 Digital outputs

**Dimensions:** 160 x 400 x 220 mm

**Weight:** 3 kg

### REQUIRED

#### UTILITIES (PROVIDED BY THE CUSTOMER)

- Power supply: 24 Vdc
- Compressed air supply: 5...6 bar

### SUPPLIED WITH

#### THEORETICAL-EXPERIMENTAL HANDBOOK

Presentation of the equipment, experiments, technical specifications with electric and pneumatic diagrams, use and maintenance.



# WEIGHING MODULE Mod. MCS-730/EV

The module mod. MCS-730/EV is used to weigh pieces. The sensor included in this equipment enables to carry out measurements on objects of variable weight (from 0.1 to 1 kg) generating an analog output signal ranging between 0 and 10 V.

The complete control of the module mod. MCS-730/EV is carried out by a PLC (optional) linked to the system through an I/O interface box.

The PLC programming software allows the development of a wide set of automation experiences with the module mod. MCS-730/EV, working in an integrated cycle or in a stand alone mode.

Finally, the module mod. MCS-730/EV supervision is carried out with the software mod. SV/EV.



## TRAINING PROGRAM:

The training program that can be developed with the module mod. MCS-730/EV includes:

- Principles of electronics
- Operation of weight sensors

## TECHNICAL SPECIFICATIONS:

Modular unit assembled on a aluminium section bar structure. It includes I/O interface box with:

- $\varnothing = 2$  mm terminals
- Cable with 25-pole D-SUB plug connector

Besides performing the function of control board for the module, this interface box also enables the students to carry out electrical measurements on the components of the module.

The control of the module is possible through the follow PLC training panels (not supplied):

- PLC training panels mod. PLC-V7/EV or mod. PLC-V8/EV: manages the module through  $\varnothing = 2$  mm terminals.

In case one of these two panels is used, a 24 Vdc power supply is already mounted on board.

Sensors and actuators:

- Weight sensor

Station inputs and outputs:

- 1 Analog output

**Dimensions:** 160 x 400 x 220 mm

**Weight:** 2.8 kg

## REQUIRED

### UTILITIES (PROVIDED BY THE CUSTOMER)

- Power supply: 24 Vdc

## SUPPLIED WITH

### THEORETICAL-EXPERIMENTAL HANDBOOK

Presentation of the equipment, experiments, technical specifications with electric and pneumatic diagrams, use and maintenance.



# STORAGE MODULE FOR PRISMATIC PIECES Mod. MCS-740/EV

The module mod. MCS-740/EV is used to distribute prismatic pieces. It has been designed to work with the module of conveyor belt mod. MCS-700/EV.

Pieces are expelled by a double-acting cylinder controlled by a 5/2-way solenoid valve.

The presence of pieces in the column is detected by a microswitch sensor, whereas the position of the cylinder is detected by two REED sensors.

The complete control of the module mod. MCS-740/EV is carried out by a PLC (optional) linked to the system through an I/O interface box.

The PLC programming software allows the development of a wide set of automation experiences with the module mod. MCS-740/EV, working in an integrated cycle or in a stand alone mode.

Finally, the module mod. MCS-740/EV supervision is carried out with the software mod. SV/EV.

## TRAINING PROGRAM:

The training program that can be developed with the module mod. MCS-740/EV includes:

- Principles of electro-pneumatics
- Operation of microswitch sensors
- Operation of REED sensors

## TECHNICAL SPECIFICATIONS:

Modular unit assembled on a aluminium section bar structure. It includes I/O interface box with:

- $\varnothing = 2$  mm terminals
- Cable with 25-pole D-SUB plug connector

Besides performing the function of control board for the module, this interface box also enables the students to carry out electrical measurements on the components of the module.

The control of the module is possible through the follow PLC training panels (not supplied):

- PLC training panels mod. PLC-V7/EV or mod. PLC-V8/EV: manages the module through  $\varnothing = 2$  mm terminals.

In case one of these two panels is used, a 24 Vdc power supply is already mounted on board.

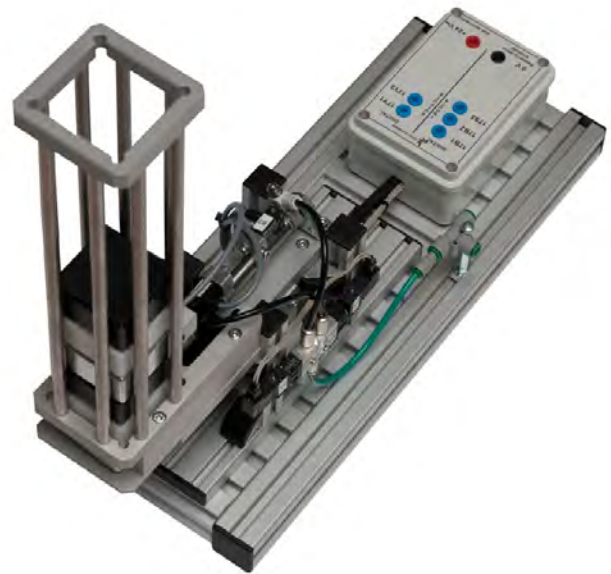

Sensors and actuators:

- 1 Microswitch sensor
- 2 REED sensors
- 1 5/2 electrovalve

Station inputs and outputs:

- 3 Digital inputs
- 2 Digital outputs

**Dimensions:** 160 x 400 x 30 mm

**Weight:** 2.5 kg

## REQUIRED

### UTILITIES (PROVIDED BY THE CUSTOMER)

- Power supply: 24 Vdc
- Compressed air supply: 5...6 bar

## SUPPLIED WITH

### THEORETICAL-EXPERIMENTAL HANDBOOK

Presentation of the equipment, experiments, technical specifications with electric and pneumatic diagrams, use and maintenance.

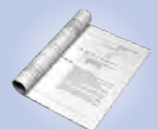

# BOX OF TOOLS AND WORKPIECES Mod. ATZ/EV

The box mod. ATZ/EV includes:

- 1 flat screwdriver
- 1 cross-point screwdriver
- Set of hexagonal allen keys
- Set of couplings for the pneumatic circuit
- Tube cutter
- Set of connectors for linking up stations
- Set of plugs for 20 x 20 mm aluminium profiles
- Set of plugs for 30 x 30 mm aluminium profiles
- 15 workpieces

**Dimensions:** 250 x 200 x 80 mm

**Weight:** 1 kg



# AIR SERVICE UNIT Mod. SRA/EV

The Air service unit mod. SRA/EV for the pneumatic supply of mechatronic systems consists of a filter and a pressure regulator with manometer equipped with a 3/2 valve in series with the filter. Pressure adjustment range from 0.5 to 7 bar. This is a recommended unit for a mechatronics system.

**Dimensions:** 80 x 80 x 120 mm

**Weight:** 1 kg



# PUSHBUTTON PANEL

## Mod. PULS/EV

The pushbutton panel for the control of stations mod. PULS/EV is linked directly to the PLC mod. PLC-V7/EV and mod. PLC-V8/EV through 16 safety terminals  $\varnothing=2$  mm.

The controls available are:

- Start 1
- Stop 1
- Start 2
- Stop 2
- Reset
- Emergency

**Dimensions:** 220 x 70 x 60 mm

**Weight:** 0.5 kg



# SILENCED COMPRESSOR

## Mod. 3409A

Capacity: 9 lt

Flow: 30 lt/min

Operating pressure: 8 bar

Safety valve

**Noise level: 40 dB/m**

Power: 0.25 hp

Motor with thermal protection

Dimensions: 330 x 330 x 450 mm

Power supply: 230 Vac  $\pm 10\%$  50 Hz





# 26-b



ME

AUTOMATION TECHNOLOGIES

## WORKING CELLS & AUTOMATED PRODUCTION LINES

<b>AUTOMATIC PIECES IDENTIFICATION AND SELECTION CENTRE CONTROLLED BY PLC</b>	Mod. MCS-A1/EV	ME 24
<b>AUTOMATIC PIECES IDENTIFICATION, THICKNESS MEASUREMENT AND STORAGE LINE CONTROLLED BY PLC</b>	Mod. MCS-B1/EV	ME 25
<b>MULTILEVEL STORAGE SYSTEM WITH PIECES IDENTIFICATION STATION ON ROTARY INDEXING TABLE IN CLOSED LOOP MODE</b>	Mod. MCS-C1/EV	ME 26
<b>AUTOMATIC MULTISTATION LINE FOR SAMPLES TEST AND WORKING</b>	Mod. MCS-D1/EV	ME 27
<b>AUTOMATIC MULTILEVEL STORAGE FOR PRODUCT SAMPLES WORKING</b>	Mod. MCS-E1/EV	ME 28
<b>AUTOMATIC WEIGHTING AND SELECTION SYSTEM WITH PNEUMATIC ROBOT AND DOUBLE CONVEYOR</b>	Mod. MCS-F1/EV	ME 29
<b>MULTILEVEL STORAGE SYSTEM WITH PIECE TESTING STATION ON ROTARY INDEXING TABLE AND CONVEYOR MODULE IN CLOSED LOOP MODE</b>	Mod. MCS-G1/EV	ME 30

www.elettronicaveneta.com

26D-E-ME

# AUTOMATIC PIECES IDENTIFICATION AND SELECTION CENTRE CONTROLLED BY PLC

## Mod. MCS-A1/EV

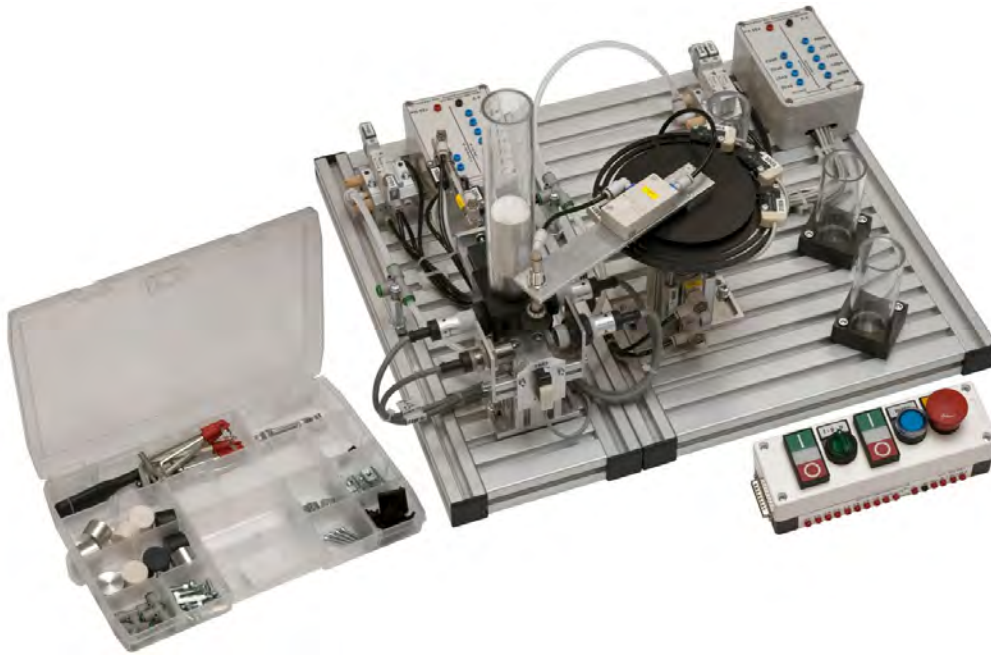

The mechatronic system **mod. MCS-A1/EV** consists of the following elements:

- Piece identification and distribution module mod. MCS-500/EV
- Rotating storage module mod. MCS-610/EV
- Pushbutton panel mod. PULS/EV
- Box of tools and workpieces mod. ATZ/EV

### Description of the cycle:

The working cycle consists of:

- The piece is ejected from the cylindrical magazine on to the identification surface.
- A sensor detects the presence of the piece on the surface.
- Two sensors (inductive, optical) detect the material of the piece (aluminum, plastic) and the color
- The rotating manipulator picks up the piece by means of a suction cup.
- The piece is released in one of the three cylindrical magazines. One magazine collects the aluminum pieces, one the white plastic pieces and one the black plastic pieces.

A PLC (not included) is required for controlling the process and must have at least:

- 14 digital inputs 24 VDC
- 6 digital outputs 24 VDC, 0.5 A

### Suggested PLC:

1 PLC trainer mod. PLC-V8/EV. Connection to the modules is carried out via 2 mm sockets.

### Alternative:

- 1 PLC trainer mod. PLC-V7/EV with programming and simulation software mod. SW7/EV. Connection to the modules is carried out via 2 mm sockets.

**Dimensions:** 600 x 400 x 270 mm

**Weight:** 8 kg

### OPTIONAL

**SUPERVISION SOFTWARE - Mod. SV/EV**  
**AIR SERVICE UNIT - Mod. SRA/EV**  
**SILENCED COMPRESSOR - Mod. 3409A**  
**WORKING TABLE - Mod. TOP/EV**

# AUTOMATIC PIECES IDENTIFICATION, THICKNESS MEASUREMENT AND STORAGE LINE CONTROLLED BY PLC Mod. MCS-B1/EV

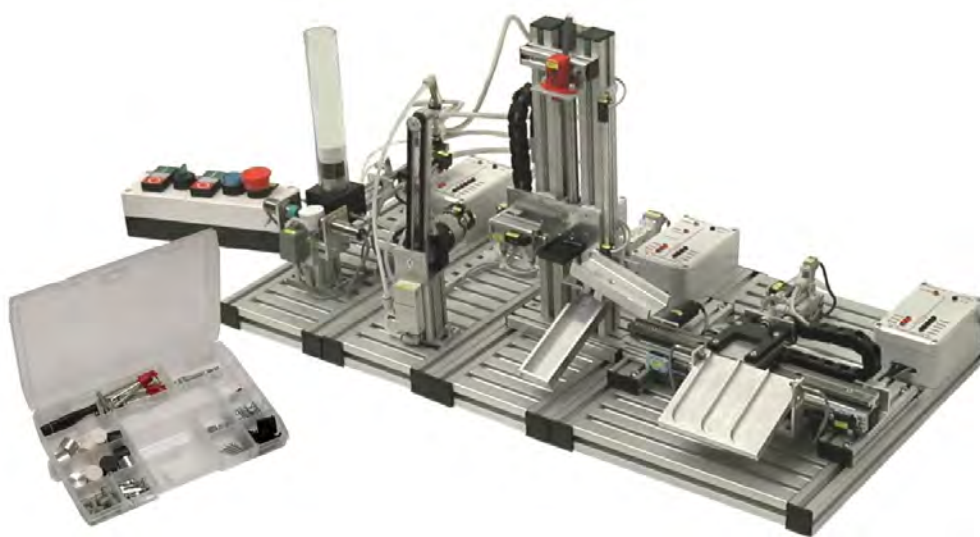

The mechatronic system **mod. MCS-B1/EV** consists of the following elements:

- Piece identification and distribution module mod. MCS-500/EV
- Swivel arm and manipulator module mod. MCS-510/EV
- Module for measuring the thickness of pieces mod. MCS-520/EV
- Linear storage module mod. MCS-530/EV
- Pushbutton panel mod. PULS/EV
- Box of tools and workpieces mod. ATZ/EV

#### Description of the cycle:

The working cycle consists of:

- The piece is ejected from the cylindrical magazine on to the identification surface.
- A sensor detects the presence of the piece on the surface.
- Sensors (inductive, optical) detect the material and color of the piece.
- The piece is transported to the subsequent station by means of the swivel arm manipulator.
- The thickness of the piece is detected and ejected on to one of two slides: compliant or non-compliant.
- The pieces are stored consistent with the data collected from the previous stations.

A PLC (not included) is required for controlling the process and must have at least:

- 20 digital inputs 24 VDC
- 11 digital outputs 24 VDC, 0.5 A
- 1 Analog input 0-10 V

#### Suggested PLC:

2 PLC trainers mod. PLC-V8/EV interconnected via PROFINET industrial network. Connection to the modules is carried out via 2 mm sockets.

#### Alternative:

- 1 PLC trainer mod. PLC-V7/EV with programming and simulation software mod. SW7/EV. Connection to the modules is carried out via 2 mm sockets.

**Dimensions:** 1200 x 400 x 400 mm

**Weight:** 17 kg

#### OPTIONAL

**SUPERVISION SOFTWARE - Mod. SV/EV**  
**AIR SERVICE UNIT - Mod. SRA/EV**  
**SILENCED COMPRESSOR - Mod. 3409A**  
**WORKING TABLE - Mod. TOP/EV**

# MULTILEVEL STORAGE SYSTEM WITH PIECES IDENTIFICATION STATION ON ROTARY INDEXING TABLE IN CLOSED LOOP MODE Mod. MCS-C1/EV



The mechatronic system **mod. MCS-C1/EV** consists of the following elements:

- Cartesian control storage module mod. MCS-620/EV
- Pneumatic arm module mod. MCS-590/EV
- Rotary indexing table module mod. MCS-570/EV
- Pushbutton panel mod. PULS/EV
- Touchscreen operator panel T7-IOP/EV
- Box of tools and workpieces mod. ATZ/EV

#### Description of the cycle:

Starting from the three-level storage module in which the work pieces are arranged in a jumbled fashion, the working cycle, totally controlled by PLC, consists of:

- Withdrawing the piece from the storage module
- Transporting the piece to the Pieces Identification Module by means of the Pick-and-Place module
- Identification of the material/color of the piece by means of a set of sensors.
- The display of the identification result
- Removing the piece from the Rotary Indexing Table after identification.
- Positioning the piece in the respective cell of the Cartesian Storage module

A PLC (not included) is required for controlling the process and must have at least:

- 20 digital inputs 24 VDC
- 13 digital outputs 24 VDC, 0.5 A

#### Suggested PLC:

2 PLC trainers mod. PLC-V8/EV interconnected via PROFINET industrial network. Connection to the modules is carried out via 2 mm sockets.

#### Alternative:

- 1 PLC trainer mod. PLC-V7/EV with programming and simulation software mod. SW7/EV. Connection to the modules is carried out via 2 mm sockets.

**Dimensions:** 1200 x 400 x 350 mm

**Weight:** 17 kg

#### OPTIONAL

**SUPERVISION SOFTWARE - Mod. SV/EV**  
**AIR SERVICE UNIT - Mod. SRA/EV**  
**SILENCED COMPRESSOR - Mod. 3409A**  
**WORKING TABLE - Mod. TOP/EV**

# AUTOMATIC MULTISTATION LINE FOR SAMPLES TEST AND WORKING

## Mod. MCS-D1/EV

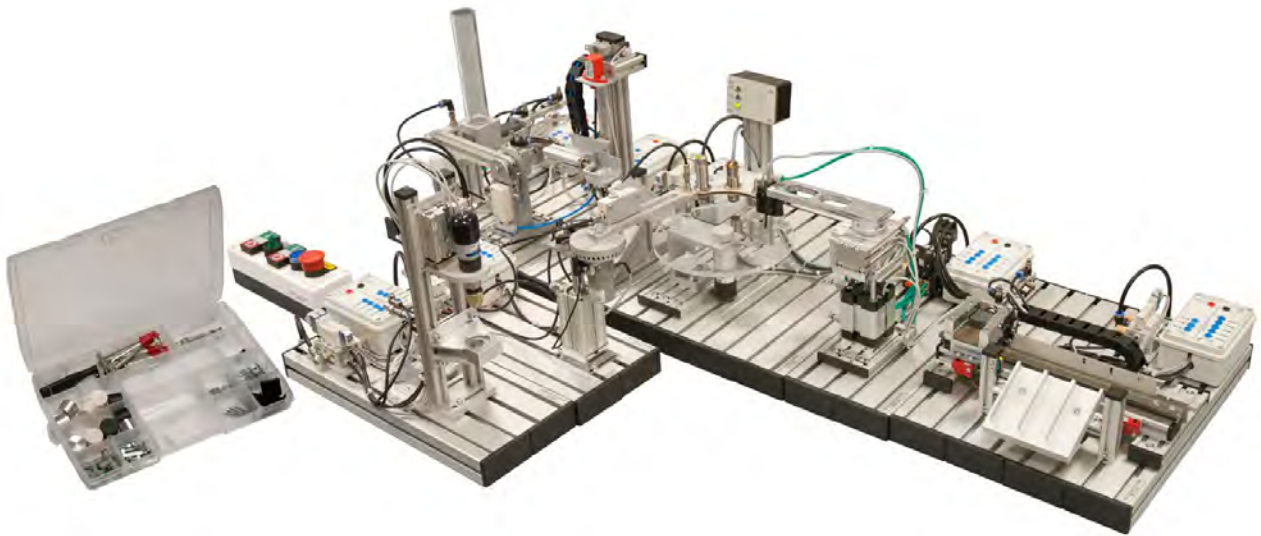

The mechatronic system **mod. MCS-D1/EV** consists of the following elements:

- Pieces distribution module mod. MCS-505/EV
- Swivel arm manipulator module mod. MCS-510/EV
- Module for measuring the thickness of pieces mod. MCS-520/EV
- Rotary indexing table module mod. MCS-570/EV
- Pneumatic arm module mod. MCS-590/EV
- Linear storage module mod. MCS-530/EV
- Electric Pick and place module mod. MCS-580/EV
- Drilling station module mod. MCS-600/EV
- Pushbutton panel mod. PULS/EV
- Box of tools and workpieces mod. ATZ/EV

### Description of the cycle:

Starting from a cylindrical storage module where the pieces are arranged in a jumbled fashion, the working cycle, totally controlled by PLC, consists of:

- Withdrawing the piece from the piece distribution module
- Transporting the piece to the Thickness Measurement module by means of the Swivel arm and manipulator module
- Identification of the thickness and eventual piece rejection if not compliant with the set parameters
- Transporting again the piece to the Rotary Indexing table Module for material identification (plastic or aluminum) and color identification (white or black).
- Transporting the piece to the drilling module
- Returning the piece to the Rotary Indexing table module

- Finally, the worked piece is placed in the storage for finished pieces

A PLC (not included) is required for controlling the process and must have at least:

- 34 digital inputs 24 VDC
- 29 digital outputs 24 VDC, 0.5 A
- 1 Analog input 0-10 V

### Suggested PLC:

4 PLC trainers mod. PLC-V8/EV interconnected via PROFINET industrial data network. Connection to the modules is carried out via 2 mm sockets.

### Alternative:

- 2 PLC trainers mod. PLC-V7/EV with programming and simulation software mod. SW7/EV, interconnected via PROFINET industrial network or PROFIBUS data network. Connection to the modules is carried out via 2 mm sockets.

**Dimensions:** 1500 x 720 x 400 mm

**Weight:** 50 kg

### OPTIONAL

**SUPERVISION SOFTWARE - Mod. SV/EV**  
**AIR SERVICE UNIT - Mod. SRA/EV**  
**SILENCED COMPRESSOR - Mod. 3409A**  
**WORKING TABLE - Mod. TOP/EV**



# AUTOMATIC MULTILEVEL STORAGE FOR PRODUCT SAMPLES WORKING Mod. MCS-E1/EV

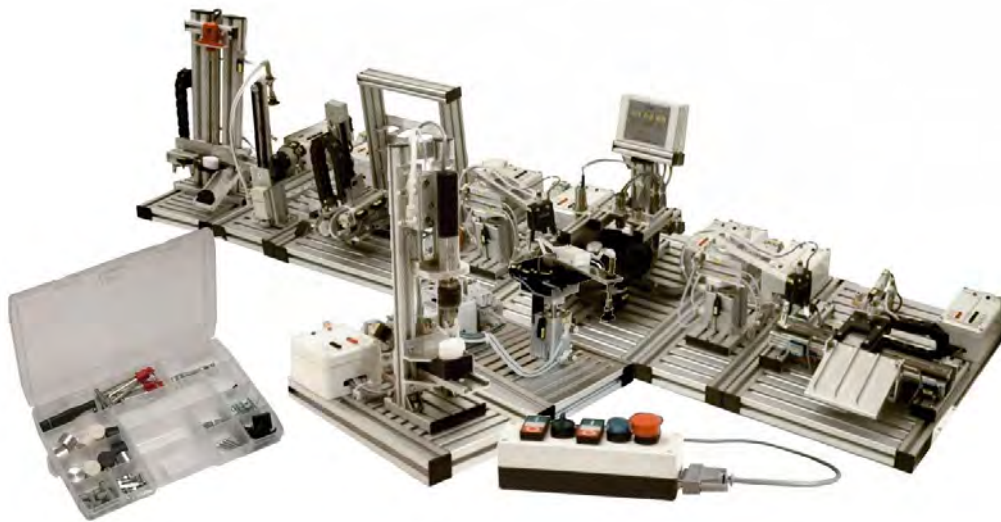

The mechatronic system **mod. MCS-E1/EV** consists of the following elements:

- Swivel arm manipulator module mod. MCS-510/EV
- Module for measuring the thickness of pieces mod. MCS-520/EV
- Rotary indexing table module mod. MCS-570/EV
- 2 Pneumatic arm modules mod. MCS-590/EV
- Linear storage module mod. MCS-530/EV
- Electric pick and place module mod. MCS-580/EV
- Drilling station module mod. MCS-600/EV
- Cartesian control storage module mod. MCS-620/EV
- Pushbutton panel mod. PULS/EV
- Touchscreen operator panel T7-IOP/EV
- Box of tools and workpieces mod. ATZ/EV

## Description of the cycle:

Starting from the three-level storage module in which the work pieces are arranged in a jumbled fashion, the working cycle, totally controlled by PLC, consists of:

- Withdrawing the piece from the Cartesian storage module
- Transporting the piece to the Thickness Measurement station by means of the Swivel arm module
- Thickness Measurement and the eventual rejection if not compliant with the set parameters
- Transporting the piece to the Rotary Indexing Table module for material and color identification
- The compliant piece follows then to the drilling module
- The drilled piece returns to the Rotary Indexing Table module
- The piece is finally stored in the storage module

A PLC (not included) is required for controlling the process and must have at least:

- 44 digital inputs 24 VDC
- 30 digital outputs 24 VDC 0.5 A
- 1 Analog input 0-10 V

## Suggested PLC:

4 PLC trainers mod. PLC-V8/EV interconnected via PROFINET industrial data network. Connection to the modules is carried out via 2 mm sockets.

## Alternative:

- 2 PLC trainers mod. PLC-V7/EV with programming and simulation software mod. SW7/EV, interconnected via PROFINET industrial network or PROFIBUS data network. Connection to the modules is carried out via 2 mm sockets.

**Dimensions:** 1900 x 720 x 400 mm

**Weight:** 35 kg

## OPTIONAL

**SUPERVISION SOFTWARE - Mod. SV/EV**  
**AIR SERVICE UNIT - Mod. SRA/EV**  
**SILENCED COMPRESSOR - Mod. 3409A**  
**WORKING TABLE - Mod. TOP/EV**

# AUTOMATIC WEIGHTING AND SELECTION SYSTEM WITH PNEUMATIC ROBOT AND DOUBLE CONVEYOR

## Mod. MCS-F1/EV

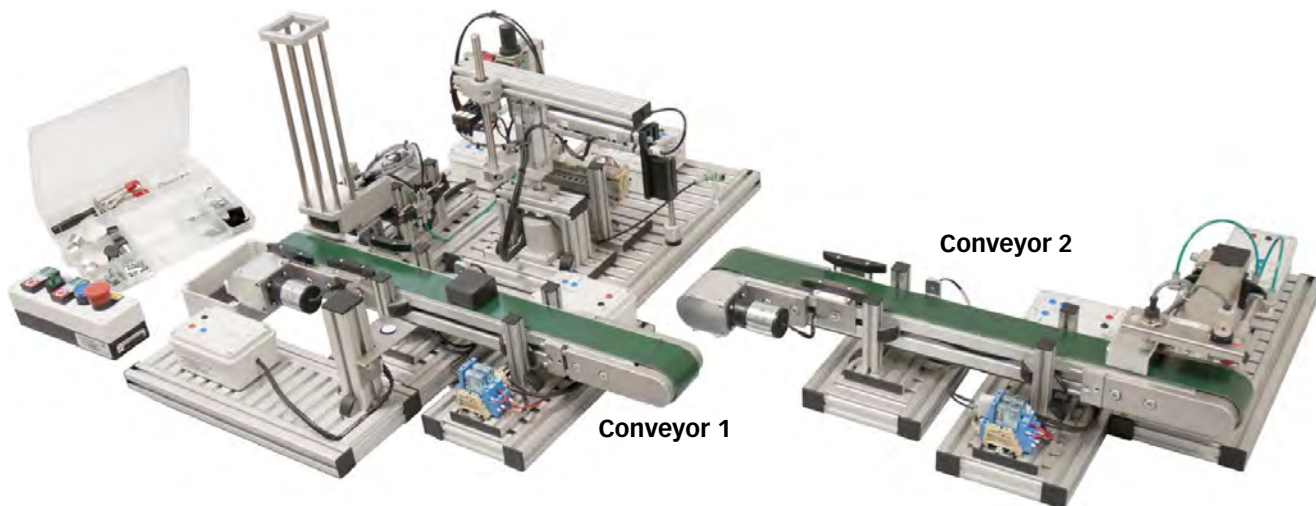

The mechatronic system **mod. MCS-F1/EV** consists of the following elements:

- Storage module for prismatic pieces mod. MCS-740/EV
- 2 conveyor modules mod. MCS-700/EV
- Robot module mod. MCS-710/EV
- Weighting module mod. MCS-730/EV
- Module for testing and selecting pieces mod. MCS-720/EV
- Pushbutton panel mod. PULS/EV
- Box of tools and workpieces mod. ATZ/EV

### Description of the cycle:

The working cycle, completely controlled by PLC, consists of:

- The piece is ejected from the storage module to the conveyor module 1
- Conveyor 1 transports the piece until the Optical Fiber sensor detects its presence and stops Conveyor 1;
- The piece is picked up by the robot module
- The piece is put on the weighting module
- Piece weighting (the piece is accepted or rejected).

If the piece complies with the preset weight, the working cycle continues as follows:

- The piece is taken from the weighting module and put on Conveyor module 2.
- Conveyor module 2 starts for material and color identification (plastic or aluminum / white or black) with inductive / optical sensors.
- Pieces are then classified and stored by the Module for Testing and Selecting pieces according to the above mentioned parameters

If the piece does not comply with the preset weight, the working cycle follows in this way:

- The piece is taken from the weighting module and put on Conveyor module 1.
- Conveyor module 1 starts again and the piece is stored in the storage module.

The complete system is managed by PLC.

PLC (not included) is required for controlling the process and must have at least:

- 17 digital inputs 24 VDC
- 13 digital outputs 24 VDC 0.5 A
- 1 Analog input 0-10 V

### Suggested PLC:

2 PLC trainers mod. PLC-V8/EV interconnected via PROFINET industrial data network. Connection to the modules is carried out via 2 mm sockets.

### Alternative:

• 2 PLC trainers mod. PLC-V7/EV with programming and simulation software mod. SW7/EV, interconnected via PROFINET industrial network or PROFIBUS data network. Connection to the modules is carried out via 2 mm sockets.

**Dimensions:** 1600 x 720 x 400 mm

**Weight:** 35 kg

### OPTIONAL

**SUPERVISION SOFTWARE - Mod. SV/EV**  
**AIR SERVICE UNIT - Mod. SRA/EV**  
**SILENCED COMPRESSOR - Mod. 3409A**  
**WORKING TABLE - Mod. TOP/EV**

# MULTILEVEL STORAGE SYSTEM WITH PIECE TESTING STATION ON ROTARY INDEXING TABLE AND CONVEYOR MODULE IN CLOSED LOOP MODE Mod. MCS-G1/EV

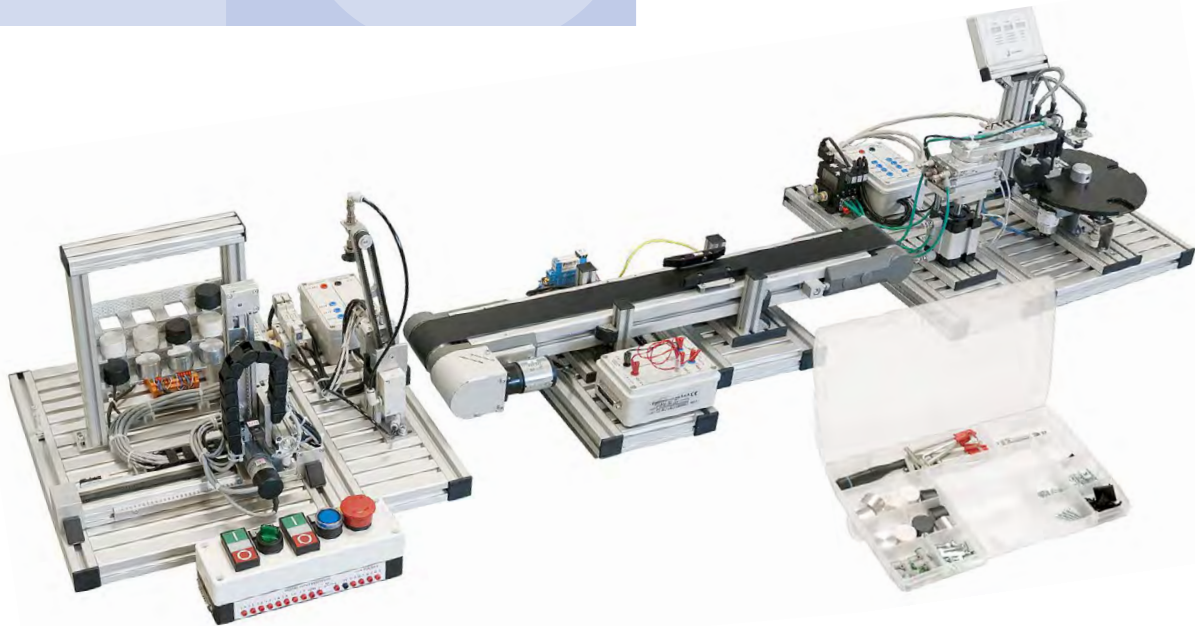

The mechatronic system mod. MCS-G1/EV consists of the following elements:

- Swivel arm manipulator module mod. MCS-510/EV
- Rotary indexing table module mod. MCS-570/EV
- Pneumatic arm module mod. MCS-590/EV
- Cartesian control storage module mod. MCS-620/EV
- Conveyor module mod. MCS-700/EV
- Pushbutton panel mod. PULS/EV
- Touchscreen operator panel T7-IOP/EV
- Box of tools and workpieces mod. ATZ/EV

## Description of the cycle:

The working cycle, completely controlled by PLC, consists of:

- The piece is withdraw from the Cartesian storage module.
- The piece is deposited on the conveyor module
- The piece is transported to the next station
- The piece is picked up from the conveyor module and released on the piece control module
- A set of sensors (inductive and optical) identify the material and color of the piece
- The piece is returned to Cartesian storage module
- The piece is stored complying with the data coming from the previous tests.

The complete system is managed by PLC.

PLC (not included) is required for controlling the process and must have at least:

- 23 digital inputs 24 VDC
- 18 digital outputs 24 VDC 0.5 A

## Suggested PLCs:

2 PLC trainers mod. PLC-V8/EV interconnected via PROFINET industrial data network. Connection to the modules is carried out via 2 mm sockets.

## Alternative:

- 2 PLC trainers mod. PLC-V7/EV with programming and simulation software mod. SW7/EV, interconnected via PROFINET industrial network or PROFIBUS data network. Connection to the modules is carried out via 2 mm sockets.

**Dimensions:** 1600 x 720 x 400 mm

**Weight:** 35 kg

## OPTIONAL

**AIR SERVICE UNIT - Mod. SRA/EV**

**SILENCED COMPRESSOR - Mod. 3409A**

**WORKING TABLE - Mod. TOP/EV**

# 26-b



ME

AUTOMATION TECHNOLOGIES

## BASIC LINE

<b>MANIPULATING ARM</b>	MOD. RDIDA/EV	ME 32
<b>TEST AND SELECTION SYSTEM WITH CONVEYOR BELT</b>	MOD. TDIDA/EV	ME 33

www.elettronicaveneta.com

26D-E-ME

# MANIPULATING ARM

## Mod. RDIDA/EV

Manipulating arm mod. RDIDA/EV is designed to grab and release pieces in two different positions. It includes a double effect cylinder to move the piece up and down, a rotary cylinder to transport the piece between the two positions and a pneumatic gripper.

Different types of sensors (magnetic / inductive) enable the identification of the arm's position and of the gripper state (close/open).

A typical working cycle is as follows. When the piece is placed on the starting point, the arm:

- Rises and turns until it is above the piece
- Lowers and grips the piece
- Rises again and makes a 180° turn
- Lowers, opens the gripper to release the piece and rises again

### TRAINING PROGRAM:

- Working cycle analysis
- System I/O definition
- Process diagram
- Working cycle phases list
- Logic scheme definition
- Analysis of potential problems
- Program writing

### TECHNICAL SPECIFICATIONS:

#### Electric characteristics

- Rotary actuator with flange
- Gripper
- 1 inductive sensor
- 3 magnetic sensors
- 2 5/2 monostable electrovalves
- 1 5/2 bistable electrovalves
- 5 flow regulators
- 10 Terminals  $\varnothing$  4mm

#### Mechanic characteristics

Silk screen synoptic bakelite panel with pins.

A PLC (not included) is needed to control the process. Minimum requirements:

- 4 24Vcc digital inputs
- 4 24Vcc transistor digital outputs

#### Suggested PLC:

- PLC training panel mod. PLC-V7/EV to control the system.

#### Alternative:

- PLC training panel mod. PLC-V8/EV

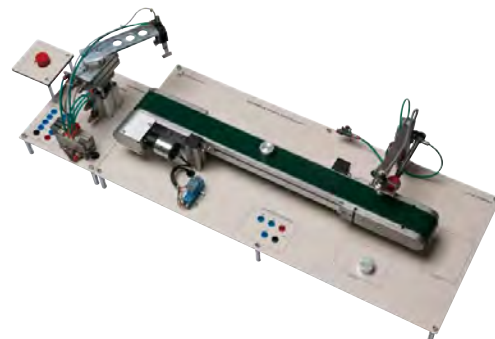
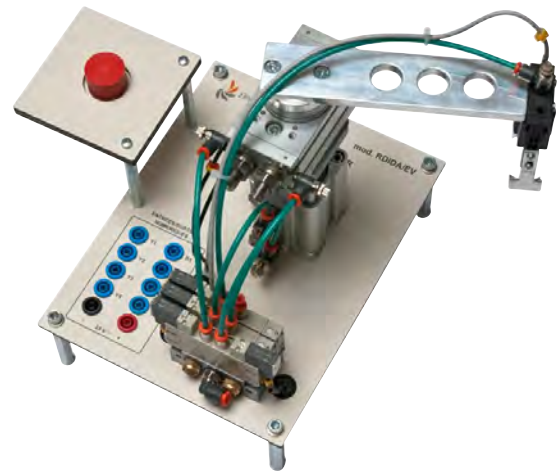

*Mechatronic system composed by units RDIDA/EV and TDIDA/EV*

**Power supply:** 24 Vcc – 0.5A (from the PLC)

**Dimensions:** 340 x 300 x 340 mm

**Net weight:** 2 kg

### REQUIRED

#### UTILITIES (PROVIDED BY THE CUSTOMER)

- Compressed Air: 4 bar

### SUPPLIED WITH

**THEORETICAL – EXPERIMENTAL  
HANDBOOK WITH SYSTEM PRESENTATION  
AND OPERATIONAL INSTRUCTIONS.**





# TEST AND SELECTION SYSTEM WITH CONVEYOR BELT

## Mod. TDIDA/EV

The system transports pieces on a conveyor belt, identifies and sorts them depending on the type of material (plastic / aluminum).

The belt is driven by a DC motor controlled by relay. Aluminum pieces are identified by an inductive sensor above the conveyor belt, and then pushed into the first warehouse by a pneumatic cylinder. Plastic pieces are not sensed by the sensor and therefore continue their way towards the second warehouse.



*Mechatronic system composed by units RDIDA/EV and TDIDA/EV*

### TRAINING PROGRAM:

- Working cycle analysis
- System I/O definition
- Process diagram
- Working cycle phases list
- Logic scheme definition
- Analysis of potential problems
- Program writing

### TECHNICAL SPECIFICATIONS:

#### Electric characteristics

- 24Vcc DC motor
- Conveyor belt length 690mm width 50mm
- 24Vcc relay
- Inductive sensor
- Simple effect cylinder
- 5/2 monostable electrovalve
- Flow regulator
- 5 Terminals  $\varnothing$  4mm

#### Mechanic characteristics

Silk screen synoptic bakelite panel with pins.

A PLC (not included) is needed to control the process. Minimum requirements:

- 1 24Vcc digital input
- 2 24Vcc transistor digital output

#### Suggested PLC:

- PLC training panel mod. PLC-V7/EV to control the system.

#### Alternative:

- PLC training panel mod. PLC-V8/EV

**Power supply:** 24 Vcc – 0.5A (from the PLC)

**Dimensions:** 800 x 350 x 300 mm

**Net weight:** 4 kg

### REQUIRED

#### UTILITIES (PROVIDED BY THE CUSTOMER)

- Compressed Air: 4 bar

### SUPPLIED WITH

**THEORETICAL – EXPERIMENTAL  
HANDBOOK WITH SYSTEM PRESENTATION  
AND OPERATIONAL INSTRUCTIONS.**



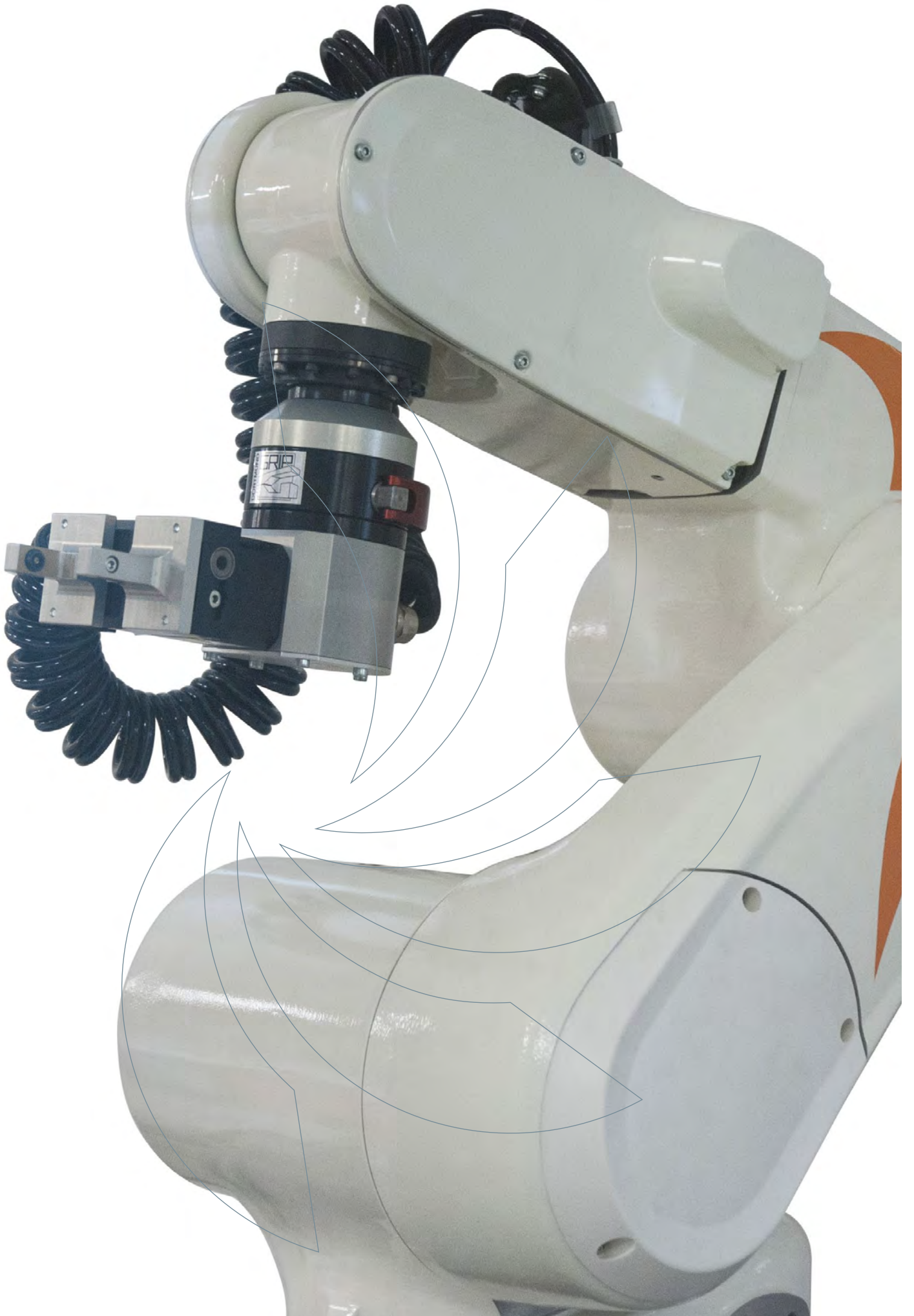

# 26-D



## ROBOTICS

RO

www.elettronicaveneta.com

**Aim:**

- Studying the characteristics, operation, programming and actual applications of industrial robots.

**Equipment:**

- Robotic work cell
- Robot station with artificial vision system
- Educational mobile robot



[www.elettronicaveneta.com](http://www.elettronicaveneta.com)

# 26-D



## ROBOTICS

<b>ROBOTIC WORKCELL</b>	Mod. KUB-1/EV	RO 5
<b>ROBOT STATION WITH ARTIFICIAL VISION SYSTEM</b>	Mod. RV3/EV	RO 7
<b>MOBILE ROBOT</b>	Mod. SPUTK/EV	RO 12
<b>LIGHT WEIGHT ROBOT</b>	Mod. LWR/EV	RO 13



# ROBOTIC WORKCELL Mod. KUB-1/EV

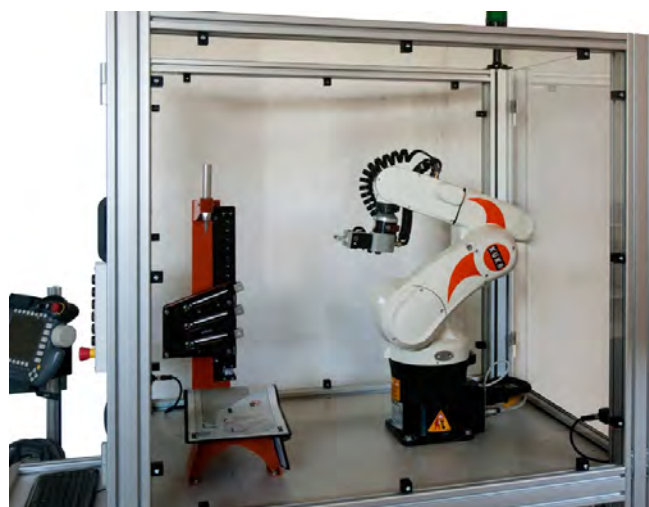

The Robotic Workcell mod. KUB-1/EV is designed to perform stock control operations and material handling in general.

The anthropomorphic robot has excellent speed, precision and flexibility features; it is an industrial robot adapted for use in the fields of education, R & D and for various laboratory applications, ensuring maximum safety for the operator.

The robot has 6 axes and closed loop servomechanisms for the continuous control of the programmed path. A powerful controller manages the movements of all the axes. This controller can be programmed via a PC by means of the specific supplied programming software; digital inputs and outputs also enable interfacing with any PLC. Just as in the industrial field, robot mod. KUB-1/EV can be programmed via teach box (included).

The Robotic Workcell mod. KUB-1/EV consists of an aluminium profile structure enclosed in which are the robot with the controller, a store for cubic pieces, cylindrical tools of varying lengths and a table with sensors.

The entire working area is protected by transparent polycarbonate panels. A control panel on the outside of the cell enables the operator to perform control actions ensuring the safety of the system in compliance with current standards.

The included programming software enables the development of a wide range of exercises related to automation of the cell mod. KUB-1/EV.

## TRAINING PROGRAM:

The training program includes the following topics:

- Structure of an anthropomorphic robot
- Robot operation analysis
- Movement technique analysis
- Control software analysis with specific emphasis on:
  - Movement algorithms
  - Self learning
- Electric drives for robotics
- Sensors
- Movement resolution
- Load capacity, speed
- Safety
- Programming the controller
- Using the teach box

## TECHNICAL SPECIFICATIONS:

Modular unit assembled within a suitable enclosed structure compliant to industrial safety standards.

### ROBOT FEATURES

Six axes robot:

Axes:	Range (Software)	Speed
Axe 1 (A 1)	$\pm 170^\circ$	375° /s
Axe 2 (A 2)	$+ 45^\circ / -190^\circ$	300° /s
Axe 3 (A 3)	$+ 166^\circ / -119^\circ$	375° /s
Axe 4 (A 4)	$\pm 190^\circ$	410° /s
Axe 5 (A 5)	$\pm 120^\circ$	410° /s
Axe 6 (A 6)	$\pm 350^\circ$	660° /s

- Electric gripper with two parallel fingers.
- Max. load: manipulable: 5 kg
- Repeatability (ISO 9283):  $\pm 0.02$  mm
- Max. speed: 8200 mm/s
- Max. inertia moment axes 4/5: 0.295 kgm<sup>2</sup>
- Max. inertia moment axis 6: 0.045 kgm<sup>2</sup>

**Power Supply:** 230 Vac 50 Hz single-phase  
(Other voltages and frequency on request)

**Dimensions:** 900 x 1200 x 1900 mm

**Weight:** 100 kg

## SOFTWARE

Easy and evolved programming language, specific to robotic applications. Runs under WIN XP or higher.

Optional: 3D Design and animation software for robot cells mod. 3DKUB/EV.

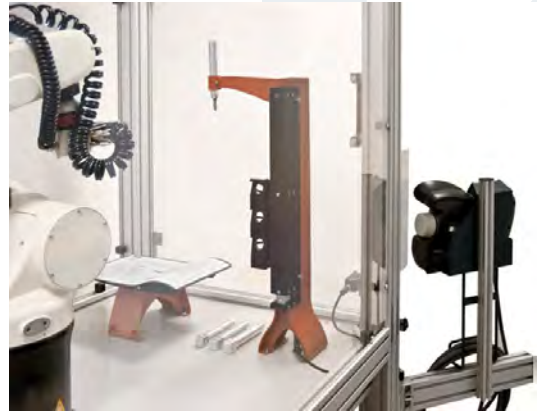

## SUPPLIED WITH

THEORETICAL-EXPERIMENTAL HANDBOOK  
OF THE STATION WITH APPLICATION GUIDE  
INSTALLATION, USE AND MAINTENANCE  
HANDBOOK



# ROBOT STATION WITH ARTIFICIAL VISION SYSTEM

## Mod. RV3/EV

Industrial robotics is one of the most successful areas for the application of artificial vision systems. The vision system is particularly useful as a robot control device. The vision is able to locate the geometric profile of an object within an area, providing the necessary coordinates to the robot for picking the object up.

In this context, the station mod. RV3/EV is an innovative training equipment in the field of robotics with artificial vision systems.

The robotic station carries out the assembly of five elements. The unit consists of a six-axis industrial robot equipped with a gripper (electrical or pneumatic) with parallel fingers. The loading of the pieces can take place from a conveyor and / or from a rotary table. Both are managed by the robot controller. In the rotary table, the robot picks the pieces up from fixed positions while in the conveyor the action is a function of the coordinates transmitted by the artificial vision system to the robot.

This means that the pieces can be placed randomly on the conveyor; the vision system will capture the piece image and process the necessary information for the proper grip of the robot.

The station includes three working modes:

- 1° Pick up of pieces from the conveyor
- 2° Pick up of pieces from the conveyor and from the rotary table.
- 3° Demo – For applications developed by the user.

For example, pick up of piece from a cell and further storing in a different cell.

The working mode selection is done via the touch screen programming keypad.

As the pieces reach the gripping position, the robot picks them up and transports them to the assembly store or to the temporary store.

If the pieces arrive already in the correct sequence for the assembly, the robot proceeds to construct the final sample directly in the assembly store. Otherwise, the robot places the pieces in a temporary store and only when the sequence is completed, does it proceed to construct the piece in the assembly store.

The final product is then stored in the "finished pieces store".



### TRAINING PROGRAM:

The training program includes the following topics:

- Structure of a six-axis robot
- Robot operation analysis
- Movement technique analysis
- Control software analysis with specific emphasis on:
  - Movement algorithms
  - Self learning
- Industrial robot applications
- Artificial vision
- Calibration
- Movement resolution
- Load capacity, speed
- Safety
- Programming the controller
- Using the teach box

## TECHNICAL SPECIFICATIONS:

Modular unit assembled on a special closed structure in compliance with industrial safety standards.

The station is composed of an aluminum profile structure inside which the robot controller is placed. The entire working area is protected by polycarbonate transparent panels.

The robot is accessible through two rear doors equipped with safety sensors.

## ROBOT CHARACTERISTICS

The robot has 6 degrees of freedom, as follows:

Base:	Movement range: $\pm 240^\circ$ ; Max speed: 225°/s
Shoulder:	Movement range: $\pm 120^\circ$ ; Max speed: 150°/s
Elbow:	Movement range: $0^\circ \div 160^\circ$ ; Max speed: 275°/s
Bottom arm:	Movement range: $\pm 200^\circ$ ; Max speed: 412°/s
Wrist torsion:	Movement range: $\pm 120^\circ$ ; Max speed: 450°/s
Wrist rotation:	Movement range: $\pm 360^\circ$ ; Max speed: 720°/s

Repeatability precision:  $\pm 0.02$  mm  
Maximum load: 3 kg; wrist downward  
Motors: AC Servomechanisms  
Position detection: absolute encoders

## ROBOT CONTROLLER

Processor type: 64-bit RISC main CPU with EMERGENCY OFF security functions and door opening sensor.  
RJ 45 interface for PC programming.  
32 digital inputs / 32 digital outputs.

## ARTIFICIAL VISION SYSTEM

Sensor: 1.3" CCD  
Resolution (pixel): 640 x 480  
Electronic shutter speed: 16  $\mu$ s  $\rightarrow$  1000 ms  
Memory:  

- Work/Program: 64 MB Flash
- Process image: 128 MB

 Communication: Ethernet Port 10/100 T Base.

Patmax algorithm for detection of object parts and characteristics.

## TOUCH SCREEN PROGRAMMING KEYPAD

Display: 6.5" TFT  
Resolution: 640 x 480 pixel  
Technology: backlit touchscreen  
Software: integrated O.S. software with menu-driven user interface.  
Information reading during operation  
Program modification with virtual keypad  
Inputs/Outputs monitoring

## CONVEYOR

Dimensions: 730 x 80 x 120 mm  
Motor:  

- Nominal power: 100 W
- Nominal torque: 0.32 N

 Servo drive: AC Safety SSCNET

The pushbutton panel and the touch screen programming keypad enable the operator to carry out control actions assuring the station safety, according to existing standards.

The station standard version is supplied with an electric gripper with parallel fingers mod. GRE/EV.

Instead of the Electrical gripper mod. GRE/EV, it is also possible to select:

- the Pneumatic handling kit mod. KMR/EV with one of the two grippers (parallel mod. GRP/EV or the 3-elements mod. GRP3/EV), or
- the Vacuum generator with filter and suction cups set mod. VACS/EV

## VISION AND ROBOT SOFTWARE

Easy and advanced programming languages specific for robotic applications with artificial vision.

O.S.: Windows 7, 32 bit version

**Power supply:** 230 Vac 50 Hz single phase  
(Other voltage and frequency on request)

**Dimensions:** 1100 x 800 x 1950 mm

**Weight:** 100 Kg

## SUPPLIED WITH

**THEORETICAL-EXPERIMENTAL HANDBOOK OF THE STATION WITH APPLICATION GUIDE  
INSTALLATION, USE AND MAINTENANCE HANDBOOK**



## OPTIONAL

- 3D design and animation software for robot cells - mod. 3DRV/EV
- Silenced compressor - mod. 3409A
- Pneumatic handling kit - mod. KMR/EV
- Parallel pneumatic gripper - mod. GRP/EV
- Pneumatic 3-elements gripper - mod. GRP3/EV
- Vacuum gener. with filter and suction cups set - mod. VACS/EV



## STATION UNITS

### MITSUBISHI RV-2SDB 6-AXIS ROBOT

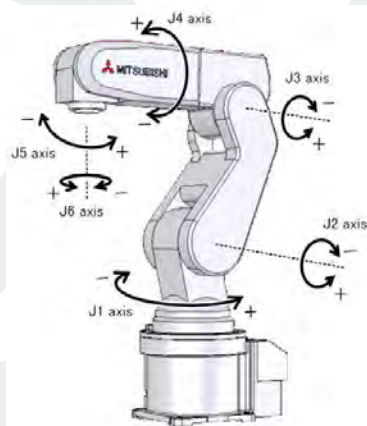

The robot has 6 degrees of freedom, as follows:

- Base: Movement range:  $\pm 240^\circ$ ;  
Max speed: 225°/s
- Shoulder: Movement range:  $\pm 120^\circ$ ;  
Max speed: 150°/s
- Elbow: Movement range:  $0^\circ \div 160^\circ$ ;  
Max speed: 275°/s
- Bottom arm: Movement range:  $\pm 200^\circ$ ;  
Max speed: 412°/s
- Wrist torsion: Movement range:  $\pm 120^\circ$ ;  
Max speed: 450°/s
- Wrist rotation: Movement range:  $\pm 360^\circ$ ;  
Max speed: 720°/s
- Repeatability precision:  $\pm 0.02$  mm
- Maximum load: 3 kg; wrist downward
- Motors: AC Servomechanisms
- Position detection: absolute encoders

### ROBOT CONTROLLER



- Processor type: 64-bit RISC main CPU with EMERGENCY OFF security functions and door opening sensor.
- RJ 45 interface for PC programming
- 32 digital inputs / 32 digital outputs.

### TOUCH SCREEN PROGRAMMING KEYPAD



- Display: 6.5" TFT - Resolution: 640 x 480 pixel
- Technology: backlit touchscreen
- Software: integrated O.S. software with menu-driven user interface.
- Information reading during operation
- Program modification with virtual keypad
- Inputs/Outputs monitoring
- Maintenance page with information on intervention intervals.
- Error page with details on the last 128 alarms.
- Interfaces: USB for USB keys, RS-422 for connection to robot controller.

### ARTIFICIAL VISION SYSTEM



- Resolution (pixel): 640 x 480
- Electronic shutter speed: 16  $\mu$ s  $\rightarrow$  1000 ms
- Memory:
  - Work/Program: 64 MB Flash
  - Process image: 128 MB
- Communication: Ethernet Port 10/100 T Base
- Patmax function for object recognition.
- White LEDs illuminator couple.

### ROTARY TABLE



- 4-position rotary table  $\varnothing = 200$  mm
- 24 Vdc geared motor
- 24 Vdc Inductive sensor  $S_n = 4$  mm



## CONVEYOR



Dimensions: 730 x 80 x 120 mm

Motor:

- Nominal power: 100 W
  - Nominal torque: 0.32 N
- Servo drive: AC Safety SSCNET

## SET OF PIECE

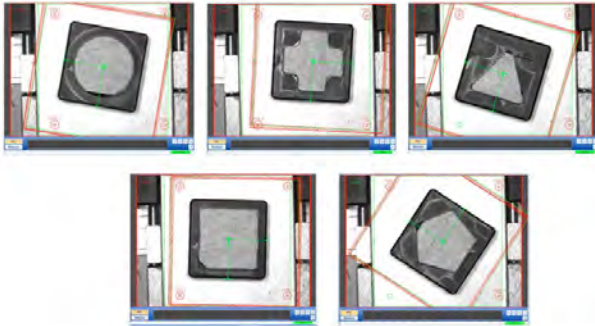

The assembly sequence set is composed of five pieces. Each piece has a different geometric figure in relief (top) and hollowed out (bottom).

The quantities provided with the station are:

Circle= 4 pieces    Cross= 1 piece  
Triangle= 1 unit    Square= 1 piece  
Pentagon = 1 piece

The assembly sequence selection (to build up the stack) can be set by the user.

## ROBOT PROGRAMMING SOFTWARE

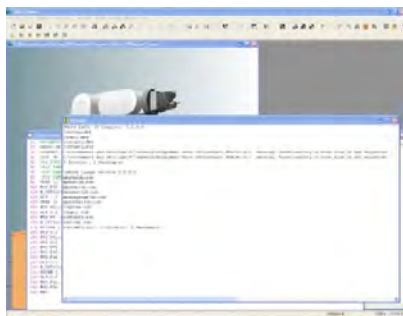

The software enables the creation of programs and their transmission to the robot with a simple click of the mouse. It is also possible to test the programs, simulate the work cycles and carry out the necessary optimizations even before commissioning.

## ARTIFICIAL VISION SOFTWARE

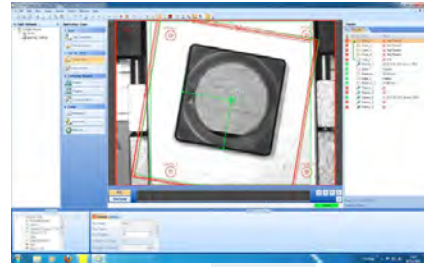

The software, through a simple interface, guides the user throughout the configuration process of the vision application. It allows to develop and quickly run the application and to optimize it as the object is being analyzed.

## ELECTRIC GRIPPER MOD. GRE/EV

Electric parallel gripper with 12 mm opening  
Repeatability precision:  $\pm 0.05$  mm  
Drive: brushless motor  
Power supply: 24 Vdc / 1.5 A



## PNEUMATIC HANDLING KIT MOD. KMR/EV

This kit is an alternative to the Electric gripper mod. GRE/EV and includes:

- Air treatment unit with manometer and pressure reducer filter
- A set of electrovalves including:
  - No. 2 5/2 bistable electrovalves
  - No. 2 3/2 monostable electrovalves

The kit can be implemented with the following elements:

## PARALLEL PNEUMATIC GRIPPER MOD. GRP/EV

Dimensions: 20  
Gripping finger race: 4 mm  
No. of gripping tools: 2  
Double effect operation  
Working pressure: 3...8 bar

## PNEUMATIC 3-ELEMENTS GRIPPER MOD. GRP3/EV

Dimensions: 35  
Gripping finger race: 4 mm  
No. of gripping tools: 3  
Double effect operation  
Working pressure: 3...8 bar

## VACUUM GENERATOR WITH FILTER AND SUCTION CUPS MOD. VACS/EV

Laval jet nominal diameter: 0.45 mm  
Modular dimension: 10 mm  
T-shaped  
Working pressure: 1...8 bar  
Max. air inlet: 15.7 l/min  
Vacuum filter  
Suction cup diameter: 20 mm

**3D ANIMATION AND DESIGN SOFTWARE  
MOD. 3DRV/EV**

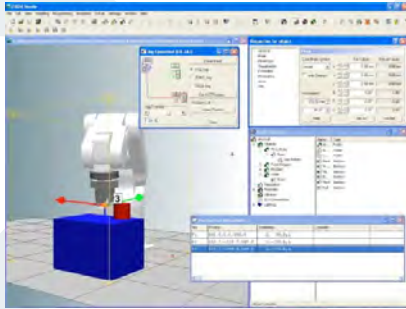

The software is a virtual learning environment that provides a wide library of objects allowing the simulation of various work settings.

Once the program is carried out, it is possible to virtually simulate it via PC and transfer it directly to the robot.

**SILENCED COMPRESSOR MOD. 3409A**



- Capacity: 9 lt
- Flow: 30 lt/min
- Operating pressure: 8 bar
- Safety valve
- Noise level: 40 dB/m**
- Power: 0.25 hp
- Motor with thermal protection
- Dimensions: 330 x 330 x 450 mm
- Power supply: 230 Vac ±10% 50 Hz

**OPERATIONAL FLOWCHART:**

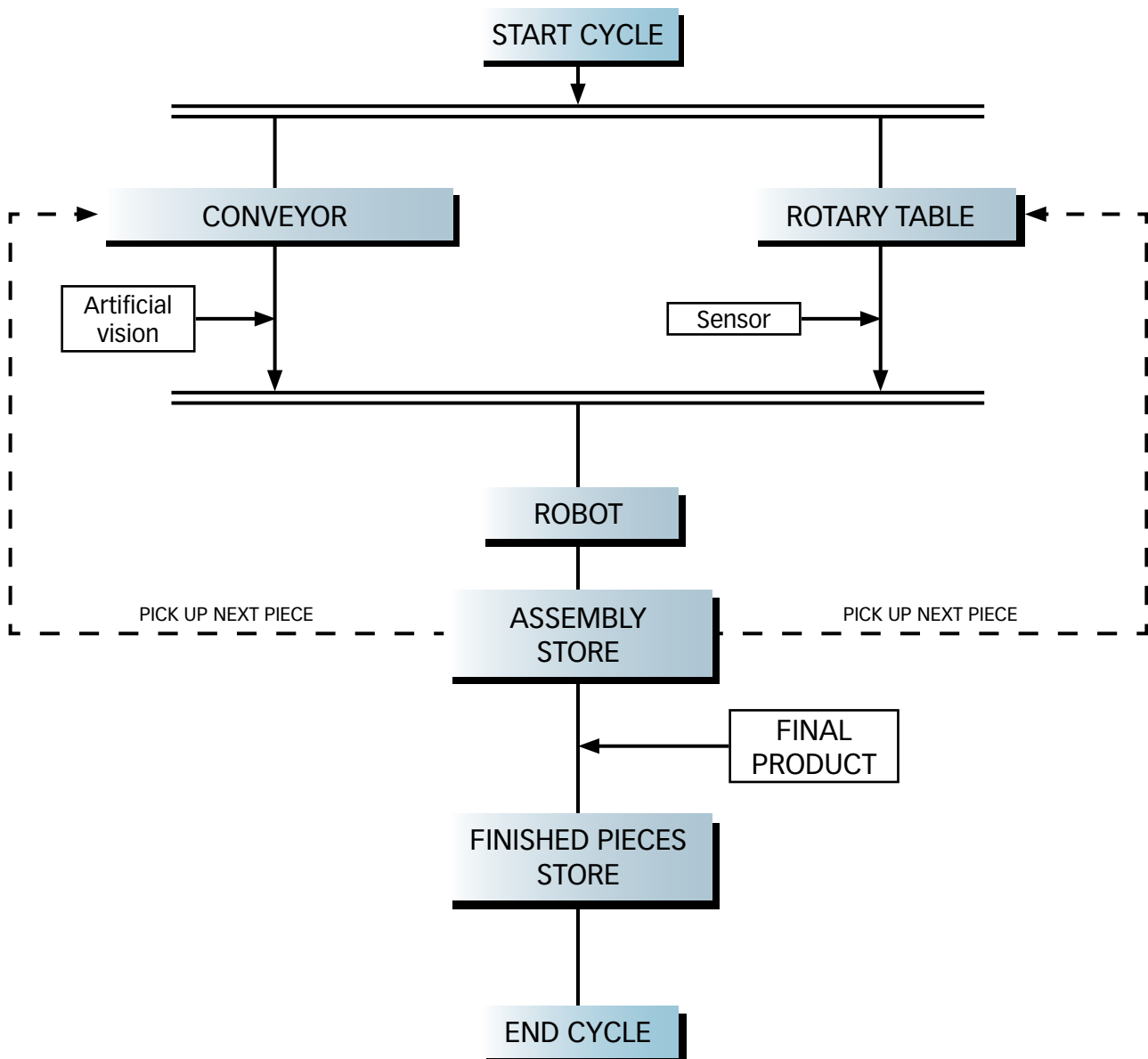

# MOBILE ROBOT

## Mod. SPUTK/EV

Mobile robot mod. SPUTK/EV has been designed expressly for the development of applications of robotics such as remote control, telepresence and autonomous navigation.

In detail, mobile robot mod. SPUTK/EV is enabled for remote control even via Internet, that is monitoring and controlling the robot from any PC networked in the web. The software of the equipment also enables to catch and save images and videos, besides programming and controlling the robot.

### TRAINING PROGRAM:

- Programming techniques
- Remote control
- Telepresence
- Studying Infrared, Ultrasonic and Passive Infrared Sensors
- Control of DC motors

### MODES OF OPERATION

Robot mod. SPUTK/EV is enabled for three modes of operation:

- **Manual mode**  
This robot moves along according to the controls sent by the user. Control signals can be sent from a local or remote PC; furthermore the robot can be controlled via a joystick (included in the equipment) or with the mouse.
- **Automatic**  
The robot moves along autonomously using the built-in sensors to avoid collisions with near obstacles.
- **Stand By**  
This mode enables the robot to be ready to receive control signals for a time period of 10 hours.

### TECHNICAL SPECIFICATIONS:

#### Motion

The robot is provided with 3 wheels enabling it to move along in any direction.

#### Mechanical and Control elements:

- 2 DC motors of 12 V; each motor can output a torque of 22 kg/cm
- Motors controlled by current and position feedback
- 2 Encoders of 1200 pulses coupled to the motors
- Diametre of wheels: 18 cm
- Max. speed: 1 m/s
- 7 degrees of freedom of which:
  - 5 degrees for head animation
  - 2 degrees for the mobile platform



#### Electronic components:

- Fully integrated WiFi system (802.11g): it supports UDP and TCP/IP protocols
- Colour videos and images with built-in audio
- Graphic LCD screen 128 x 64 for displaying icons, messages or data of sensors
- Collision sensors:
  - 3 ultrasonic sensors
  - 7 infrared sensors
  - 2 Passive Infrared sensors for detecting the heat of a human body.

#### Open programming environment:

It supports programming under MS Windows 7 (64 bit / 32 bit), Windows Vista (64 bit / 32 bit) and XP.

- Power Supply:** 230 Vac 50/60 Hz (to recharge the batteries)
- Dimensions:** diam. 40.5 cm - height 47 cm
- Weight:** 6 kg

#### SUPPLIED WITH

**THEORETICAL - EXPERIMENTAL  
HANDBOOK WITH EXERCISES**



#### SOFTWARE FOR CONTROLLING THE ROBOT

Programming in standard Microsoft Windows (MS VB and VC++) environment.

#### ACCESSORIES

- Joystick controller
- Pack of batteries and battery charger

# LIGHT WEIGHT ROBOT

## Mod. LWR/EV

The Light Weight Robot mod. LWR/EV represents state of the art technology for control and communication in industrial automation. It has distinct speed, precision and flexibility features and has been designed to fulfil specific educational and research requirements as well as a number of laboratory applications ensuring complete safety for the user.

The Light Weight Robot mod. LWR/EV is made of aluminium with an outside soft cover and provided with 6 axes controlled by closed loop servomechanisms for continuous control of the programmed trajectory.

The robot movement is carried out by a powerful controller which manages the movements of all axes. The controller is programmable via PC by means of a specific programming software (included). It is provided with numerous communication interfaces to the outside world such as:

- Communication interfaces to sensors, actuators, PLC's or other high level systems
- TCP/IP support for LAN networks
- Connection to industrial networks with CAN Open protocol
- USB connection

The programming software enables the development of a wide variety of exercises. The user-friendly and intuitive graphic interface allows programming the robot to perform various tasks in the field of industrial automation.

The robot control can be integrated with other software programmes such as LabView and Matlab/Simulink.

Robot control for stand alone operations can be carried out by means of any mobile device with WiFi connection and browser.

### TRAINING PROGRAM

The training program developed includes the following topics:

- Structure of a robot
- Robot function analysis
- Movement technique analysis
- Control software analysis
- Robot application in the industrial field
- Electrical actuators for robotics
- Movement resolutions

### TECHNICAL SPECIFICATIONS

- Mechanical construction:
  - Inside Aluminium
  - Outside soft cover



- Degrees of freedom: 6 (3 for positioning, 3 for end tool orientation)
- Operating range: >800mm
- Payload: 1.5Kg
- High resolution optical relative encoders and Hall sensors
- Repetition accuracy:  $\pm 0.1$  mm
- Brushless DC Motors
- Bus System: CAN Open
- Interfaces: Inputs/Outputs 24Vcc, Industrial ethernet, Web Services
- Max speed: 100-120°/sec per joint
- Power consumption: about 200 watt / 24-36 volt

**Power Supply:** 230 Vac 50 Hz single phase  
(Other voltage and frequency on request)

**Weight:** 10 kg

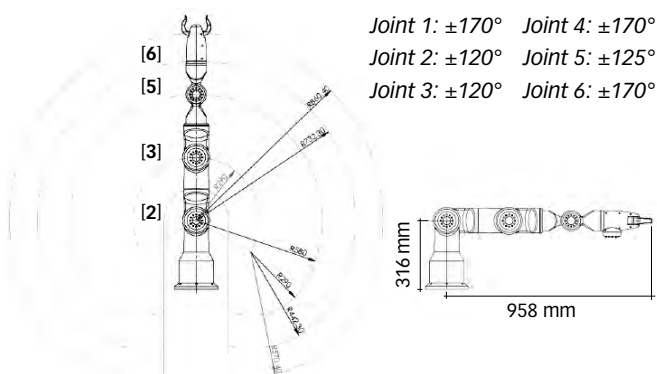

### SUPPLIED WITH

**THEORETICAL-EXPERIMENTAL HANDBOOK:  
INTRODUCTION AND APPLICATION GUIDE**



### SOFTWARE

Simple and evolved programming language specific to robotic applications. Development environment Windows 7 or higher.



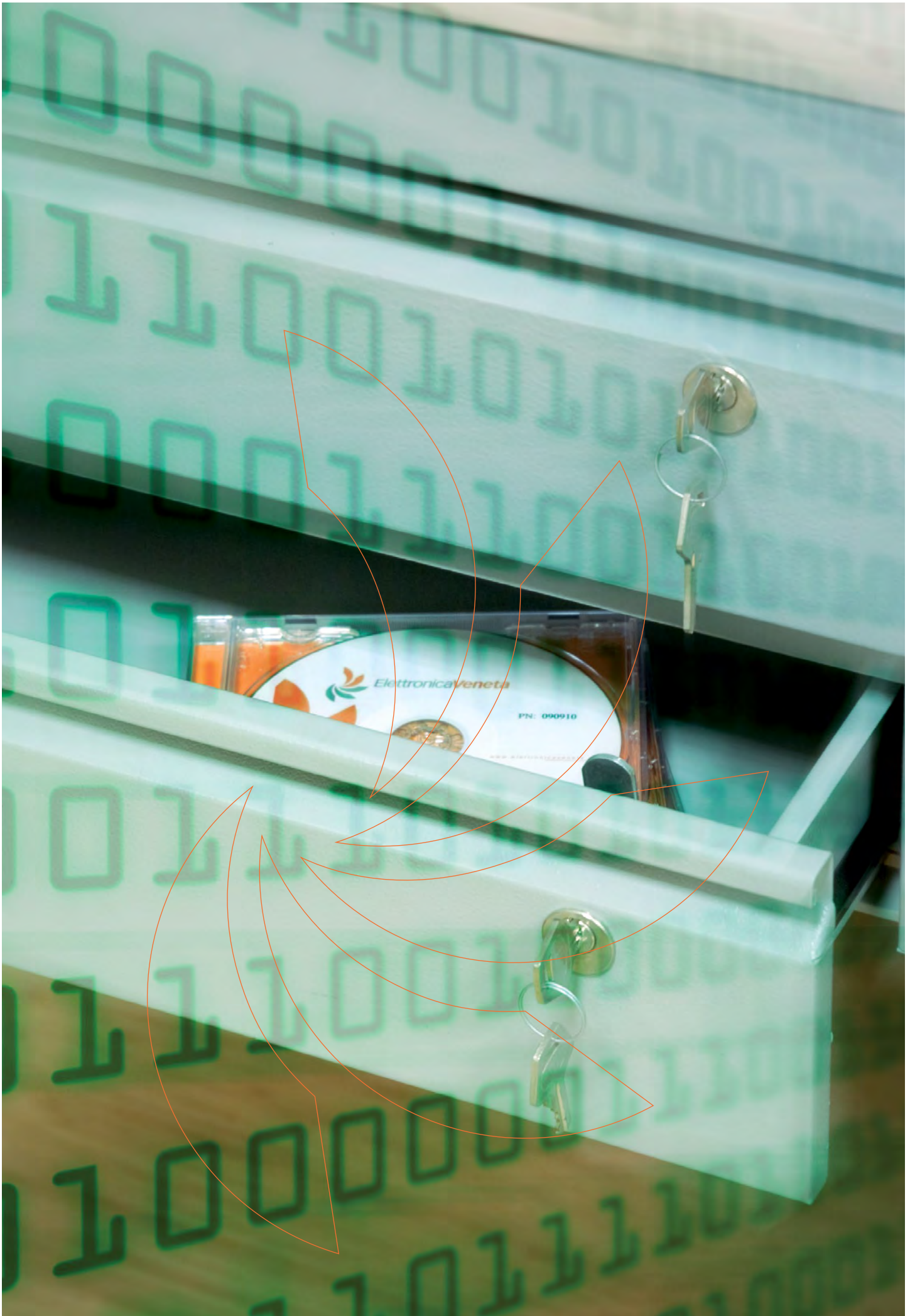



# 26-D



## SOFTWARE AND INTERFACES

www.elettronicaveneta.com

### **Aim:**

- Using advanced tools of virtual design of industrial automation circuits. Putting what has been simulated virtually in practice.



### **Equipment:**

- Design, simulation and animation software for industrial automation
- Trainer / Software interface board

# 26-D



## SOFTWARE AND INTERFACES

	<b>SOFTWARE</b>	<b>SI 4</b>
	<b>INTERFACES</b>	<b>SI 19</b>

# 26-D

SI



AUTOMATION TECHNOLOGIES

## SOFTWARE

<b>PLC PROGRAMMING, SIMULATION AND SUPERVISION SOFTWARE</b>	Mod. SW7/EV	SI 5
<b>PLC SUPERVISION SOFTWARE - ADVANCED LEVEL</b>	Mod. SV/EV	SI 7
<b>SCADA - SUPERVISORY CONTROL AND DATA ACQUISITION - SOFTWARE FOR PID CONTROLLERS</b>	Mod. SV-1/EV	SI 8
<b>DESIGN, SIMULATION AND ANIMATION SOFTWARE FOR INDUSTRIAL AUTOMATION</b>	Mod. SW-CAI/EV	SI 9
<b>DESIGN, SIMULATION AND ANIMATION SOFTWARE FOR THE STUDY OF PNEUMATICS AND ELECTRO-PNEUMATICS</b>	Mod. SW-AIR/EV	SI 11
<b>DESIGN, SIMULATION AND ANIMATION SOFTWARE FOR THE STUDY OF HYDRAULICS AND ELECTRO-HYDRAULICS</b>	Mod. SW-HYD/EV	SI 13
<b>DESIGN, SIMULATION AND ANIMATION SOFTWARE FOR THE STUDY OF ELECTRO-PNEUMATICS &amp; ELECTRO OIL-HYDRAULICS</b>	Mod. SW-FLU/EV	SI 14
<b>DESIGN, SIMULATION AND ANIMATION SOFTWARE FOR THE STUDY OF ELECTRICAL ENGINEERING</b>	Mod. SW-ELT/EV	SI 15
<b>3D DESIGN AND ANIMATION SOFTWARE FOR ROBOT CELLS</b>	Mod. 3DKUB/EV	SI 16
<b>3D DESIGN AND ANIMATION SOFTWARE FOR ROBOT CELLS</b>	Mod. 3DRV/EV	SI 17
<b>VIRTUAL PROCESS SIMULATION SOFTWARE</b>	Mod. SSP-VR/EV	SI 18

www.elettronicaveneta.com

26D-E-SI

# PLC PROGRAMMING, SIMULATION AND SUPERVISION SOFTWARE

## Mod. SW7/EV

Software mod. SW7/EV is a software of configuration, programming, simulation, control and diagnostics; it can be used in OFFLINE mode (PLC simulated via software) or with PLC trainer mod. PLC-V7/EV.

It offers the availability of a lot of standard libraries concerning:

- Logical combination of bits
- Timers
- Counters
- Comparison operations
- Mathematical functions
- Transfer operations
- Conversion operations
- Logical combination by word
- Shiftment and rotation
- PID Control

It includes the following programming languages:

- Instruction list (AWL)
- Contacts (KOP)
- Logic (FUP)
- Graph
- SCL

It complies with standard DIN EN 6.1131-3.

The simulation of PLC is managed by a specific software block included in the program where all the operating modes of an actual PLC are integrated.

This software enables to create some HMI pages with a basic library of objects and elements (line, ellipse, circle, I/O field, pushbutton, bar graph, curves on Cartesian chart, etc...). Installing also the (optional) supervision software of advanced level mod. SV/EV will enrich the library with graphic elements concerning various sectors (Chemistry, Industry, Building, HVAC etc...).

### TRAINING PROGRAM

Software mod. SW7/EV enables students to learn the programming of PLCs by explaining the theoretical and experimental analysis of the following exercises:

- Architecture of a PLC, synchronous cycles, asynchronous cycles and cycles with priority
- Run-time, cycle time and response time
- Boolean algebra (NO and NC contact, logical functions)
- Programming in AWL, KOP, FUP, GRAPH, SCL languages
- Functions of combinational and sequential logic
- Addressing operations



- Timers & counters
- PID control
- Creation of HMI pages

The software block of PLC simulation enables to test the program (OFFLINE) before it is transferred onto the actual device. The software is also provided with the following examples of exercises carried out:

- Logic gates
- Function modules
- Starting an asynchronous motor
- Reversal of rotation in an asynchronous motor
- Star/delta starting of an asynchronous motor
- Star/delta reversal of rotation
- Linear position control
- Starting a Dahlander motor
- Motor with two separate coils
- Starting an asynchronous wound-rotor motor

### PC SYSTEM REQUIREMENTS

- Processor: Core i5, 2.4 GHz, or equivalent
- Working storage:
  - 3 GB for 32-bit operating system
  - 8 GB for 64-bit operating system
- Hard disk: 250 GB S-ATA HDD
- Graphics: min. 1280 x 1024
- Screen: 15" SXGA + display (1400 x 1050)
- USB port
- Ethernet port
- O.S.: Windows 7 SP1 (32-bit or 64-bit)

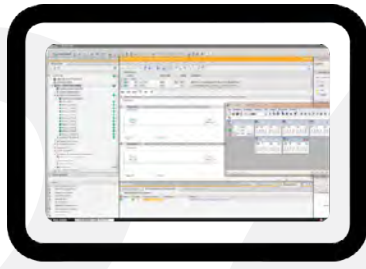

*Offline mode: the PLC is simulated via software*

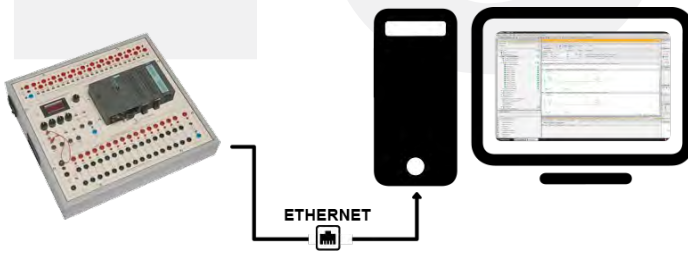

*Online mode: the software is connected with the PLC training panel mod. PLC-V7/EV*

**SUPPLIED WITH**

SOFTWARE PROGRAMMING HANDBOOK ON DVD-ROM AND CD-ROM WITH EXAMPLES OF PROGRAMMING

**OPTIONAL**

PLC TRAINING PANEL  
Mod. PLC-V7/EV



PLC SUPERVISION SOFTWARE  
ADVANCED LEVEL Mod. SV/EV



# PLC SUPERVISION SOFTWARE - ADVANCED LEVEL

## Mod. SV/EV

Software mod. SV/EV (6-LICENSE) enables to carry out functions of HMI supervision and data acquisition in a plant from a local or remote workstation equipped with a PC.

It includes:

- Software with graphic pages, in Windows O.S. for overall supervision functions of the plant from a local or remote PC workstation.
- Advanced library of objects, elements and graphics for different fields (Chemistry, Industry, Building, HVAC, etc...).
- Necessary drivers for the interface to PLC training panels mod. PLC-V7/EV and mod. PLC-V8/EV.

### TRAINING PROGRAM

The training program which can be carried out with the use of software mod. SV/EV concerns the following exercises:

- Monitoring the project and general system settings
- Creation and management of plant supervision pages
- Use of a rich library with a wide range of subsystems characterizing industrial plants
- On-line retrieval of the data concerning the process
- Definition of charts, tables, curves
- Acquisition and filing of events for diagnostics
- Alarm control with insertion of customized messages

### TECHNICAL SPECIFICATIONS:

The main characteristics are:

- Data acquisition and monitoring
- Graphic and instrumental pages
- Historical and Real-Time trends
- Managing alarms and configurable prints
- Parametric recipes
- Differentiated access levels
- Exporting data to the most common data bases

This software includes a Run-Time and development licence.

#### PC SYSTEM REQUIREMENTS

- Processor: Core i5, 2.4 GHz, or equivalent
- Working storage:
  - 3 GB for 32-bit operating system
  - 8 GB for 64-bit operating system
- Hard disk: 250 GB S-ATA HDD
- Graphics: min. 1280 x 1024
- Screen: 15" SXGA + display (1400 x 1050)
- USB port
- Ethernet port
- O.S.: Windows 7 SP1 (32-bit or 64-bit)

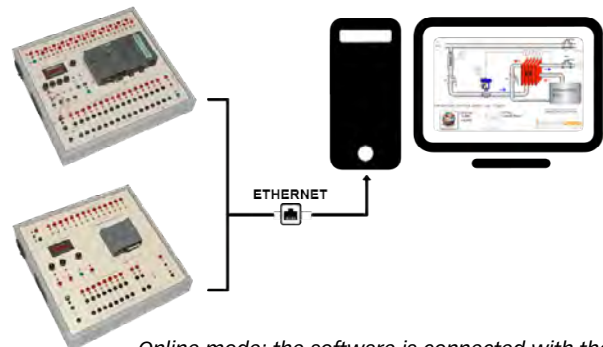
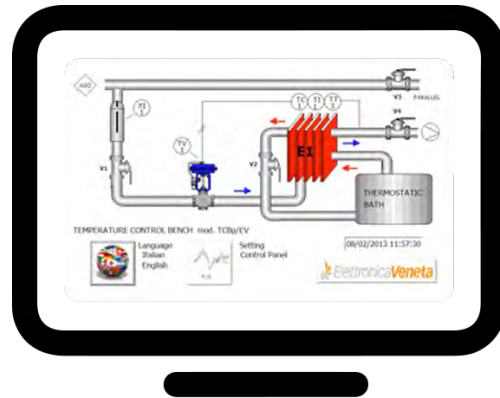

Online mode: the software is connected with the PLC training panel mod. PLC-V7/EV or mod. PLC-V8/EV

**SUPPLIED WITH**  
SOFTWARE PROGRAMMING  
HANDBOOK ON CD-ROM

**OPTIONAL**  
PLC TRAINING PANEL  
Mod. PLC-V7/EV, or



PLC TRAINING PANEL  
Mod. PLC-V8/EV



# SCADA - SUPERVISORY CONTROL AND DATA ACQUISITION - SOFTWARE FOR PID CONTROLLERS

## Mod. SV-1/EV

SCADA (Supervisory Control And Data Acquisition) software mod. SV-1/EV enables to implement supervision and data acquisition functions in a plant from a local or remote workstation equipped with a PC.

It includes:

- Software with graphic pages, in Windows O.S. for overall supervision functions of the plant from a local or remote PC workstation.
- Driver Modbus TCP/IP being necessary for the interface to Trainer mod. PID-S1/EV.

### TRAINING PROGRAM:

The training program which can be carried out with the use of software mod. SV-1/EV concerns the following exercises:

- Monitoring the project and general system settings
- Creation and management of plant supervision pages
- Use of a rich library with a wide range of subsystems characterizing industrial plants
- Managing background images in bitmap format
- On-line retrieval of the data concerning the process
- Definition of charts, tables, curves
- Acquisition and filing of events for diagnostics
- Alarm control with insertion of customized messages

### TECHNICAL SPECIFICATIONS:

The main characteristics are:

- Data acquisition and monitoring
- Graphic and instrumental pages
- Historical and Real-Time trends
- Managing alarms and configurable prints
- Parametric recipes
- Differentiated access levels
- Exporting data to the most common data bases

This software includes a Run-Time and development licence.

### PC SYSTEM REQUIREMENTS

- USB port
- Ethernet port
- O. S.: Windows 7, 32-bit

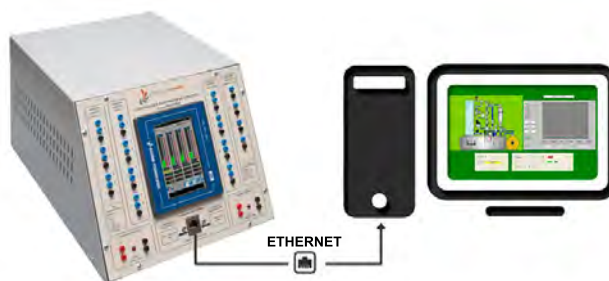

Supervision and data acquisition of PID controller mod. PID-S1/EV (in option) by software mod. SV-1/EV via Modbus TCP/IP protocol.

### SUPPLIED WITH

USER MANUAL



### OPTIONAL

FOUR LOOPS PID DIGITAL CONTROLLER  
Mod. PID-S1/EV



# DESIGN, SIMULATION AND ANIMATION SOFTWARE FOR INDUSTRIAL AUTOMATION

## Mod. SW-CAI/EV

The software mod. SW-CAI/EV constitutes a very powerful educational tool to develop theoretical lessons and laboratory practical exercises. This software allows the user to design, simulate and animate circuits for the following technical fields:

- Pneumatics and Proportional Pneumatics
- Hydraulics and proportional hydraulics
- Electrical control (standard IEC, JIC)
- Digital Electronics
- Electrical engineering

It also allows:

- Creating programs in Ladder logic for PLCs Siemens and Allen Bradley IEC 61131-3
- Creating Grafset sequences
- Creating HMI and control panels interfaces
- Interfacing with the real circuit

### SYMBOLS LIBRARY:



International symbols library for all the fields mentioned above, according to ISO, DIN, IEC, NEMA. The user is able to create partial or specific libraries to facilitate the design of new symbols. One important feature is the "Component Dimensioning" function, or the possibility to assign specific characteristics to the used symbols.

### PNEUMATICS AND PROPORTIONAL PNEUMATICS

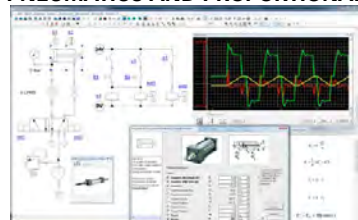

The library includes all the necessary symbols to design a pneumatic circuit: compressed air sources, single and double effect linear cylinders, limit switches, push buttons, valves, timer, motors, etc. it is possible to create open loop and closed loop control circuits.



### OIL CONTROL HYDRAULICS AND

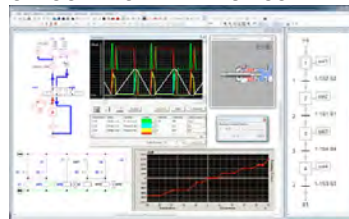

### PROPORTIONAL OIL CONTROL HYDRAULICS

Complying with standards ISO 1219-1 and ISO 1219-2, the libraries of oil control hydraulics and proportional hydraulics include all the symbols of the components needed to assemble a circuit. A library includes hundreds of symbols such as directional valves, pumps, motors, engines, cylinders, etc...

### ELECTRICAL CONTROL LOGICS

This library interacts with all the components of other libraries, and allows creating electrical control logic circuits. It is then possible to make electro-pneumatic projects. It includes push buttons, relays, coils, etc.

### HMI AND CONTROL PANEL



This module allows to create animations and control panels. The graphical library contains several objects such as switches, push buttons, potentiometers, etc.

## ELECTRICAL ENGINEERING

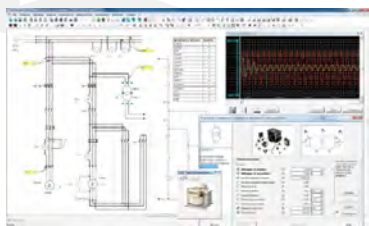

The Library offers a wide range of components to create electrical D.C and/or A.C. circuits. The user can modify the simulation parameters like the resistance, inductance, torque, frequency, mutual inductance of the rotor or mutual inductance stator of the motor, the constant of inertia etc. With this library you can draw a circuit, simulate its operation and look for possible errors before passing to its realization.

## CUT-AWAY COMPONENTS ANIMATION

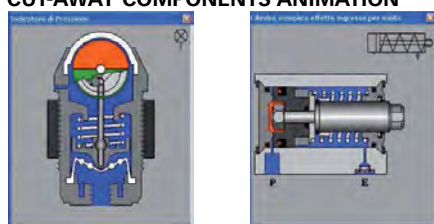

The 3D animated cut-away components show the internal operation of the devices. The animations are synchronized with the circuit simulation.

## GRAFSET



This module allows the implementation of control structures according to IEC61131-3 standard. This universal method can be used together with other libraries to perform the control of complex pneumatics projects.

The Grafset programming technique helps to develop complex automatic sequences and to test them before transferring them to the PLC. The programs developed with this software can be exported in a format compatible with Siemens S7 PLCs and in XML format.

## PROGRAMMABLE LOGIC CONTROLLER (PLC)

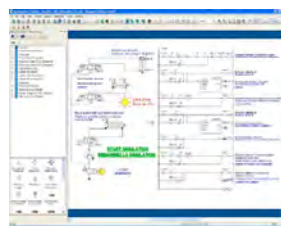

This software has three libraries in LADDER logic that includes the symbols of the manufacturers: Allen Bradley™, Siemens™, and of standard IEC61131-3. These libraries also contain the set of instructions for operating in LADDER logic, as well as contacts, timers, counters, mathematical functions, etc...

These libraries enable to write a program in LADDER logic and to simulate its operation and troubleshooting before it is transferred to the PLC.

## DIGITAL ELECTRONICS



This library provides a wide range of standard logic components like inverter, logic ports, flip-flops, counters, scrolling registers, comparators, push buttons, LEDs, 7-segments display, multiplexer, etc.

## PC SYSTEM REQUIREMENTS

- 2 USB ports
- O.S: Windows 7

## SUPPLIED WITH

THEORETICAL-EXPERIMENTAL HANDBOOK  
WITH INTRODUCTION TO THE EXERCISES



## OPTIONAL

I/O INTERFACE:  
INTERFACE BOARD Mod. C2-IO/EV





# DESIGN, SIMULATION AND ANIMATION SOFTWARE FOR THE STUDY OF PNEUMATICS AND ELECTRO-PNEUMATICS

## Mod. SW-AIR/EV

The software mod. SW-AIR/EV constitutes a very powerful educational tool to develop theoretical lessons and laboratory practical exercises. This software allows the user to design, simulate and animate circuits for the following technical fields:

- Pneumatics and Proportional Pneumatics
- Electrical control (standard IEC, JIC).
- Digital Electronics

It also allows:

- Creating Grafcet sequences
- Interfacing with the real circuit

### SYMBOLS LIBRARY:

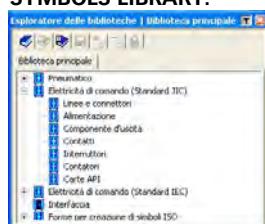

International symbols library for all the fields mentioned above, according to ISO, DIN, IEC, NEMA. The user is able to create partial or specific libraries to facilitate the design of new symbols. One important feature is the "Component Dimensioning" function, or the possibility to assign specific characteristics to the used symbols.

### PNEUMATICS AND PROPORTIONAL PNEUMATICS

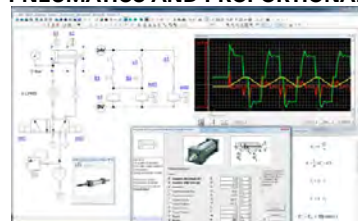

The library includes all the necessary symbols to design a pneumatic circuit: compressed air sources, single and double effect linear cylinders, limit switches, push buttons, valves, timer, motors, etc. It is possible to create open loop and closed loop control circuits.

### ELECTRICAL CONTROL LOGICS

This library interacts with all the components of other libraries, and allows creating electrical control logic circuits. It is then possible to make electro-pneumatic projects. It includes push buttons, relays, coils, etc.

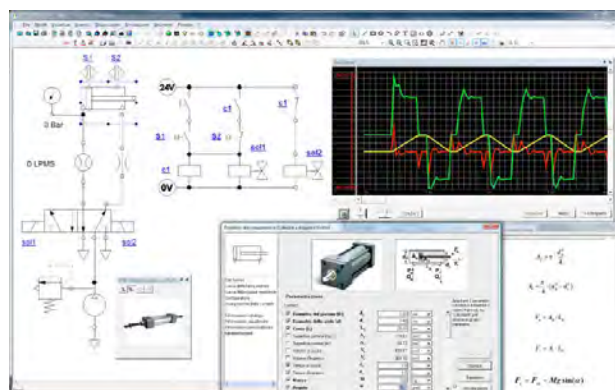

### DIGITAL ELECTRONICS



This library provides a wide range of standard logic components like inverters, logic ports, flip-flops, counters, scrolling registers, comparators, push buttons, LEDs, 7-segment displays, multiplexers, etc.

### CUT-AWAY COMPONENTS ANIMATION

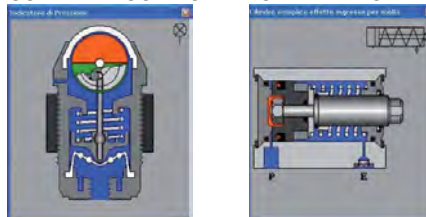

The 3D animated cut-away components show the internal operation of the devices. The animations are synchronized with the circuit simulation.



**GRAFSET**

This module allows the implementation of control structures according to IEC61131-3 standard. This universal method can be used together with other libraries to perform the control of complex pneumatics projects.

The Grafset programming technique helps to develop complex automatic sequences and to test them before transferring them to the PLC. The programs developed with this software can be exported in a format compatible with Siemens S7 PLCs and in XML format.

**PC SYSTEM REQUIREMENTS**

- 2 USB ports
- O.S: Windows 7

**SUPPLIED WITH**

THEORETICAL-EXPERIMENTAL HANDBOOK  
WITH INTRODUCTION TO THE EXERCISES

**OPTIONAL**

I/O INTERFACE:  
INTERFACE BOARD Mod. C2-IO/EV



# DESIGN, SIMULATION AND ANIMATION SOFTWARE FOR THE STUDY OF HYDRAULICS AND ELECTRO-HYDRAULICS

## Mod. SW-HYD/EV

The software mod. SW-HYD/EV constitutes a very powerful educational tool to develop theoretical lessons and laboratory practical exercises. This software allows the user to design, simulate & animate circuits for the following technical fields:

- Hydraulics and Proportional Hydraulics
- Electrical control (standard IEC, JIC).
- Digital Electronics

It also allows:

- Creating Grafcet sequences
- Interfacing with the real circuit

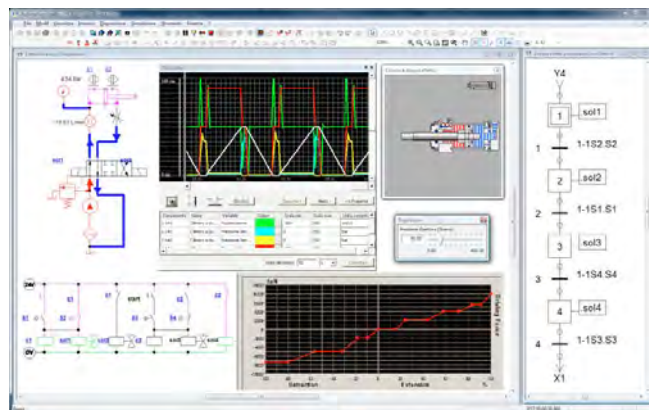

### SYMBOLS LIBRARY:

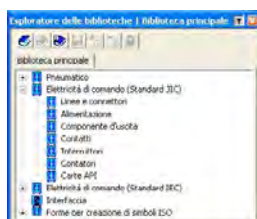

International symbols library for all the fields mentioned above, according to ISO, DIN, IEC, NEMA. The user is able to create partial or specific libraries to facilitate the design of new symbols. One important feature is the "Component Dimensioning" function, or the possibility to assign specific characteristics to the used symbols.

### HYDRAULICS AND PROPORTIONAL HYDRAULICS

In accordance with ISO 1219-1 and ISO 1219-2 standards, the hydraulics and proportional hydraulics libraries provide all the necessary symbols to design a circuit. The library includes hundreds of symbols such as directional valves, pumps, motors, cylinders, etc.

### ELECTRICAL CONTROL LOGICS

This library interacts with all the components of other libraries, and allows the creation of electrical control logic circuits. It is then possible to make electro-hydraulics projects. It includes push buttons, relays, coils, etc.

### DIGITAL ELECTRONICS

This library provides a wide range of standard logic components like inverters, logic ports, flip-flops, counters, scrolling registers, comparators, push buttons, LEDs, 7-segment displays, multiplexers, etc.

### CUT-AWAY COMPONENTS ANIMATION

The 3D animated cut-away components show the internal operation of the devices. The animations are synchronized with the circuit simulation.

### GRAF CET

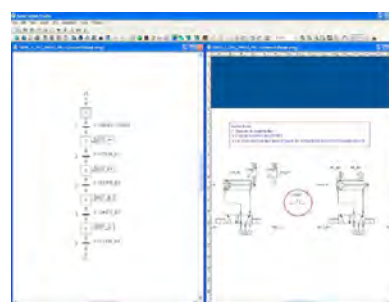

This module allows the implementation of control structures according to IEC61131-3 standard. This universal method can be used together with other libraries to perform the control of complex pneumatics projects. The Grafcet programming technique helps to develop complex automatic sequences and to test them before transferring them to the PLC. The programs developed with this software can be exported in a format compatible with Siemens S7 PLCs and in XML format.

### PC SYSTEM REQUIREMENTS

- N° 2 USB ports
- O.S: Windows 7

### SUPPLIED WITH

THEORETICAL-EXPERIMENTAL HANDBOOK WITH INTRODUCTION TO THE EXERCISES



### OPTIONAL

I/O INTERFACE:  
INTERFACE BOARD Mod. C2-IO/EV



# DESIGN, SIMULATION AND ANIMATION SOFTWARE FOR THE STUDY OF ELECTRO-PNEUMATICS & ELECTRO OIL-HYDRAULICS

## Mod. SW-FLU/EV

The software mod. SW-FLU/EV constitutes a very powerful educational tool to develop theoretical lessons and laboratory practical exercises. This software allows the user to design, simulate and animate circuits for the following technical fields:

- Pneumatics and Proportional Pneumatics
- Hydraulics and Proportional Hydraulics
- Electrical control (standard IEC, JIC).
- Digital Electronics

It also allows:

- Creating Grafcet sequences
- Interfacing with the real circuit

### SYMBOLS LIBRARY:

International symbols library for all the fields mentioned above, according to ISO, DIN, IEC, NEMA. The user is able to create partial or specific libraries to facilitate the design of new symbols. One important feature is the "Component Dimensioning" function, or the possibility to assign specific characteristics to the used symbols.

### PNEUMATICS AND PROPORTIONAL PNEUMATICS

The library includes all the necessary symbols to design a pneumatic circuit: compressed air sources, single and double effect linear cylinders, limit switches, push buttons, valves, timer, motors, etc. it is possible to create open loop and closed loop control circuits.

### HYDRAULICS AND PROPORTIONAL HYDRAULICS

In accordance with ISO 1219-1 and ISO 1219-2 standards, the hydraulics and proportional hydraulics libraries provide all the necessary symbols to design a circuit. The library includes hundreds of symbols such as directional valves, pumps, motors, cylinders, etc.

### ELECTRICAL CONTROL LOGICS

This library interacts with all the components of other libraries, and allows the creation of electrical control logic circuits. It is then possible to make electro-hydraulics projects. It includes push buttons, relays, coils, etc.

### DIGITAL ELECTRONICS

This library provides a wide range of standard logic components like inverters, logic ports, flip-flops, counters, scrolling registers, comparators, push buttons, LEDs, 7-segment displays, multiplexers, etc.

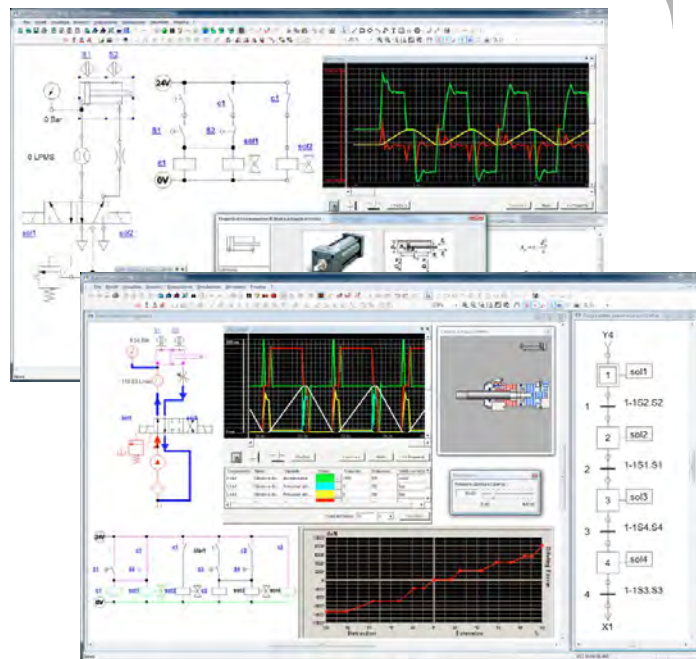

### CUT-AWAY COMPONENTS ANIMATION

The 3D animated cut-away components show the internal operation of the devices. The animations are synchronized with the circuit simulation.

### GRAF CET

This module allows the implementation of control structures according to IEC61131-3 standard. This universal method can be used together with other libraries to perform the control of complex pneumatics projects. The Grafcet programming technique helps to develop complex automatic sequences and to test them before transferring them to the PLC. The programs developed with this software can be exported in a format compatible with Siemens S7 PLCs and in XML format.

### PC SYSTEM REQUIREMENTS

- N° 2 USB ports
- O.S: Windows 7

### SUPPLIED WITH

THEORETICAL-EXPERIMENTAL HANDBOOK WITH INTRODUCTION TO THE EXERCISES



### OPTIONAL

I/O INTERFACE:  
INTERFACE BOARD Mod. C2-IO/EV



# DESIGN, SIMULATION AND ANIMATION SOFTWARE FOR THE STUDY OF ELECTRICAL ENGINEERING

## Mod. SW-ELT/EV

The software mod. SW-ELT/EV constitutes a very powerful educational tool to develop theoretical lessons and laboratory practical exercises. This software allows the user to design, simulate & animate circuits for the following technical fields:

- Electrical engineering
- Electrical control (standard IEC, JIC).
- Digital Electronics

It also allows:

- Creating HMI and control panels interfaces
- Interfacing with the real circuit

### SYMBOLS LIBRARY:



International symbols library for all the field mentioned above, according to ISO, DIN, IEC, NEMA and other standards. The user is able to create partial or specific libraries, to facilitate the design of new symbols. One important characteristic is the "Component Dimensioning" function, or the possibility to assign specific characteristics to the used symbols.

### ELECTRICAL ENGINEERING:

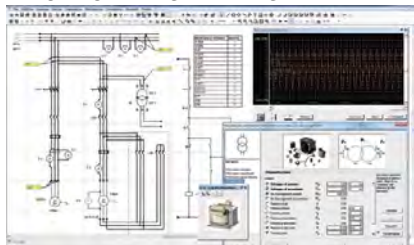

The Library offers a wide range of components to create electrical D.C and/or A.C. circuits. The user can modify the simulation parameters like the resistance, inductance, torque, frequency, mutual inductance of the rotor or mutual inductance stator of the motor, the constant of inertia etc. With this library you can draw a circuit, simulate its operation and look for possible errors before passing to its realization.

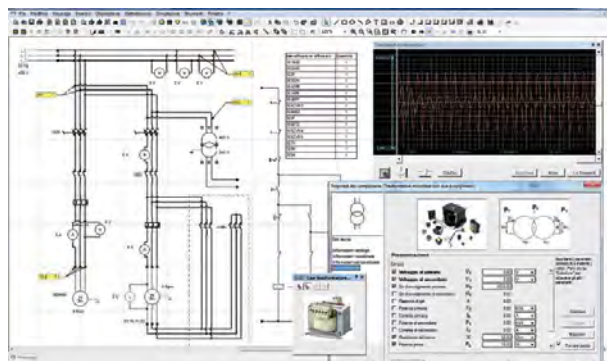

### HMI AND CONTROL PANEL:



This module allows to create animations and control panels. The graphical library contains several objects such as switches, push buttons, potentiometers, etc.

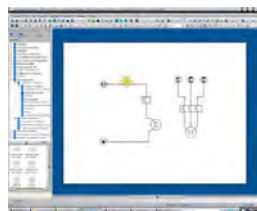

### ELECTRICAL CONTROL LOGICS:

This library interacts with all the components of other libraries and allows creating electrical control logic circuits. It is then possible to make electro-pneumatics project. It includes push buttons, relays, coils, etc.



### DIGITAL ELECTRONICS:

This library provides a wide range of standard logic components like inverter, logic ports, flip-flops, counters, scrolling registers, comparators, push buttons, LEDs, 7-segments display, multiplexer...

### PC SYSTEM REQUIREMENTS

- N° 2 USB ports
- O.S: Windows 7

### SUPPLIED WITH

THEORETICAL-EXPERIMENTAL HANDBOOK WITH INTRODUCTION TO THE EXERCISES



### OPTIONAL

I/O INTERFACE:  
INTERFACE BOARD Mod. C2-IO/EV





# 3D DESIGN AND ANIMATION SOFTWARE FOR ROBOT CELLS

## Mod. 3DKUB/EV

Software mod. 3DKUB/EV is a virtual learning environment enabling to model robot cells, to program robots and to simulate their operation. It represents a very good educational tool to understand and apply the knowledge studied in the courses of drawing, mechanics, automation, etc...

Software mod. 3DKUB/EV can be used for the offline programming of the robot included in the Robotic machining cell mod. KUB-1/EV.

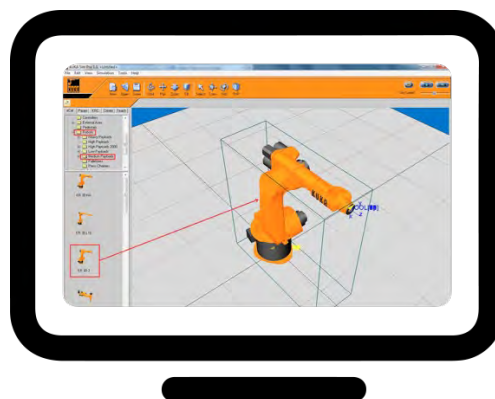

### TRAINING PROGRAM

The training program that can be carried out with the use of this software concerns the following exercises:

- Basic configuration of a robot
- Choosing the sensors/actuators
- Definition of the virtual environment
- Writing the program
- Virtual simulation of the process

### TECHNICAL SPECIFICATIONS:

This software offers a wide library of objects which can be modified. This library will also include a lot of intelligent components not only of simple geometry, but also of parametric structure (such as conveyor belts, photoelectric barriers, etc...) showing a behaviour that can be used actively in simulation. Once implemented, before being transferred to the robot, the program can be simulated virtually on the PC where the presence of collisions, as well as the duration of cycle time and other predictive information will be checked.

### PC SYSTEM REQUIREMENTS

- Processor: CPU Dual Core (not hyperthreading)
- Working store: 4 GB RAM
- Video card: 1 GB RAM
- Hard disk: 250 GB
- USB port
- Ethernet port
- O. S.: Windows 7, 64-bit

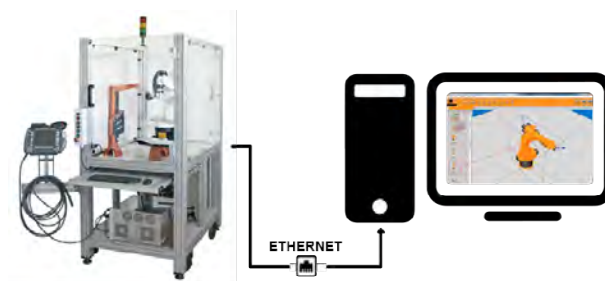

*Designing, simulating and controlling the robotic cell mod. KUB-1/EV by software mod. 3DKUB/EV.*

### SUPPLIED WITH

USER MANUAL



### OPTIONAL

ROBOTIC WORKCELL  
Mod. KUB-1/EV





# 3D DESIGN AND ANIMATION SOFTWARE FOR ROBOT CELLS

## Mod. 3DRV/EV

Software mod. 3DRV/EV is a virtual learning environment enabling to model robot cells, to program robots and to simulate their operation. It represents a very good educational tool for understanding and applying the knowledge studied in the courses of drawing, mechanics, automation, etc...

Software mod. 3DRV/EV can be used for the offline programming of the robot included in the Robotic station with artificial vision system mod. RV3/EV.

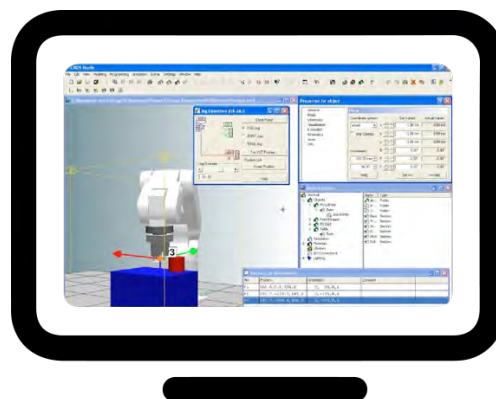

### TRAINING PROGRAM

The training program that can be carried out with the use of this software concerns the following exercises:

- Basic configuration of a robot
- Choosing the sensors/actuators
- Definition of the virtual environment
- Writing the program
- Virtual simulation of the process

### TECHNICAL SPECIFICATIONS:

This software offers a wide library of objects which can be modified. This library will also include a lot of intelligent components not only of simple geometry, but also of parametric structure (such as conveyor belts, photoelectric barriers, etc...) showing a behaviour that can be used actively in simulation. Once implemented, before being transferred to the robot, the program can be simulated virtually on the PC where the presence of collisions, as well as the duration of cycle time and other predictive information will be checked.

#### PC SYSTEM REQUIREMENTS

- Processor: CPU Dual Core (not hyperthreading)
- Working store: 4 GB RAM
- Video card: 1 GB RAM
- Hard disk: 250 GB
- USB port
- Ethernet port
- O. S.: Windows 7, 32/64 bit

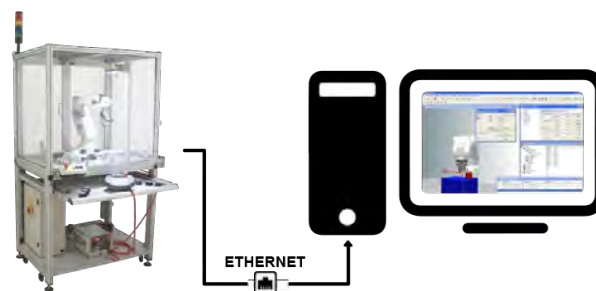

*Designing, simulating and controlling the robotic station with artificial vision system mod. RV3/EV by software mod. 3DRV/EV.*

#### SUPPLIED WITH

USER MANUAL



#### OPTIONAL

ROBOT STATION WITH ARTIFICIAL VISION SYSTEM - Mod. RV3/EV



# VIRTUAL PROCESS SIMULATION SOFTWARE

## Mod. SSP-VR/EV

Simulating various systems and installations is very useful in training practice; in fact, the physical part of an installation is often complex and cumbersome, but in the meantime it is essential from a functional point of view; simulators are designed to replace this part of systems.

Virtual process simulation software mod. SSP-VR/EV enables to design and simulate industrial production systems that employ the most widely used technologies of automation.

The software includes an extensive library of automated production line units (like conveyors, pick and place, sensors, etc.) that can be combined together in production processes.

The student who is operating the software can modify one of the fully editable virtual systems already developed, based on the solutions most widely used in industrial lines, or start afresh with a new one. All projects can be saved and recovered later.

Virtual process simulation software mod. SSP-VR/EV must be installed on a PC running Windows and interfaced with the PLC Training panel mod. PLC-V8/EV (not included).

The aim of the software is to teach students how to develop a PLC program that will control the simulated process.

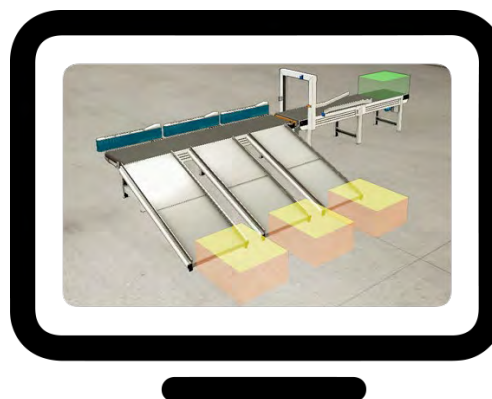

### TECHNICAL SPECIFICATIONS

- 3D graphics
- Sound effects
- Industrial processes virtualized systems
- Object library
- Interactivity with the items
- Fault simulation (short circuit / open circuit)

### PC SYSTEM REQUIREMENTS

- Running Windows 7 or higher
- Intel Core2 2GHz processor or AMD 64x2 2GHz or higher
- 1 GB memory
- Available hard disk drive space: 500 MB
- DirectX: 9.0c
- USB port
- Ethernet port
- Recommended: graphics card running two displays

### TRAINING PROGRAM

The training program includes the development of programs to manage exercises such as:

- Storing station
- Sorting station
- Automated station designed to join together different product lines
- Pick & Place station
- Automated warehouse

In addition, guidelines are provided for creating new virtual systems or for modifying those previously designed.



### REQUIRED (NOT INCLUDED)

PLC TRAINING PANEL  
Mod. PLC-V8/EV

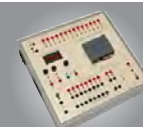

# 26-D



## INTERFACES

INTERFACE BOARD

Mod. C2-IO/EV

SI 20

# INTERFACE BOARD

## Mod. C2-IO/EV

The interface board mod. C2-IO/EV is a valid educational tool for the Lecturer in his Lab exercises. The board, used with the design, simulation and animation software for industrial automation applications, allows to control and supervise from PC the following trainers:

- Electro-pneumatics
- Electro-hydraulics
- Mechatronics
- Electrical engineering

The interface board mod. C2-IO/EV includes:

- 8 digital inputs and 8 relay outputs over terminals dia.  $\varnothing = 4$  mm and  $\varnothing = 2$  mm.
- A simulator with switches of permanent and impulsive states, connectable to the digital inputs.
- A power supply 24 Vdc - 2A
- A device to connect the interface board to a USB port

### Operation

Connect the interface board mod. C2-IO/EV to a PC that has installed one of the following softwares:

- mod. SW-CAI/EV
- mod. SW-AIR/EV
- mod. SW-HYD/EV
- mod. SW-FLU/EV
- mod. SW-ELT/EV
- mod. SW-PLC/EV

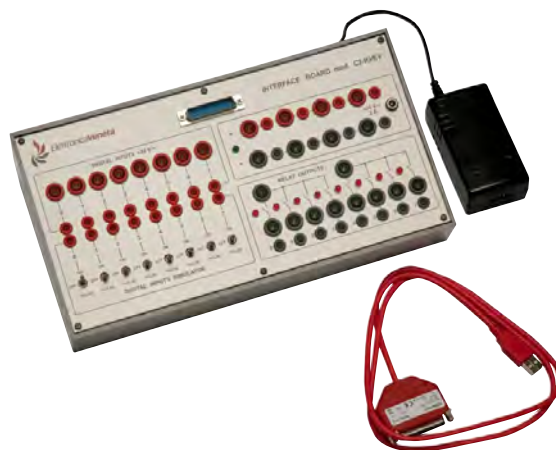

The interface allows to connect to the digital inputs:

- Limit switches
- Pushbuttons NC and NO
- Emergency Pushbuttons NC and NO
- Switches NC and NO, etc.

The outputs are able to control:

- Electrovalves
- Lamps
- Relays, etc.

### TECHNICAL SPECIFICATIONS:

- The unit is contained in a plastic box
- Front panel with silk screen of the components and diagrams
- Power supply 24 VDC – 2 A
- 8 digital inputs 24 VDC
- 8 relay outputs: 250 Vac – 2 A or 30 Vdc – 2 A
- 8 switches simulator with permanent and impulsive states
- Standard safety terminals  $\varnothing = 4$  mm and  $\varnothing = 2$  mm to connect the external devices to the unit I/O.
- PC connection through USB port

**Power supply:** 230 Vac 50 Hz single-phase - 100 VA  
(Other voltage and frequency on request)

**Dimensions:** 320 x 80 x 90 mm

**Weight:** 0.9 Kg

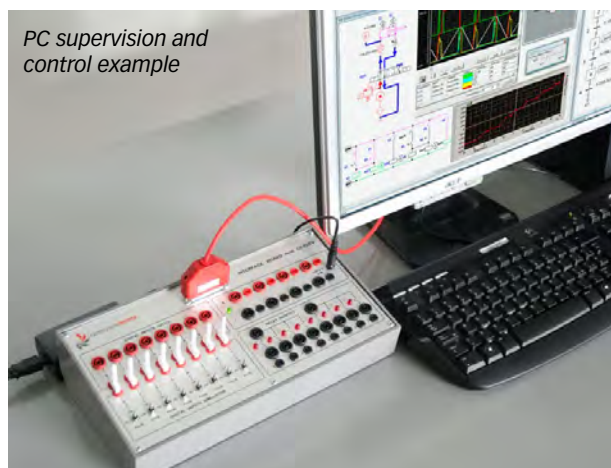

*PC supervision and control example*

### SUPPLIED WITH

INSTALLATION AND USE MANUAL



# PRODUCTS INDEX

SORTED ALPHABETICALLY BY MODEL

**AUTOMATION  
TECHNOLOGIES**  
CATALOGUE No. 26-D

<b>PN</b>	<b>PNEUMATICS</b>
<b>HY</b>	<b>OIL-HYDRAULICS - ELECTRO OIL-HYDRAULICS - PROPORTIONAL OIL-HYDRAULICS</b>
<b>PL</b>	<b>PLC - SIMULATORS AND APPLICATIONS</b>
<b>PC</b>	<b>PROCESS CONTROLS</b>
<b>ME</b>	<b>MECHATRONICS</b>
<b>RO</b>	<b>ROBOTICS</b>
<b>SI</b>	<b>SOFTWARE AND INTERFACES</b>

MODEL	DESCRIPTION	PAGE
3409A	SILENCED COMPRESSOR	ME 22
3DKUB/EV	3D DESIGN AND ANIMATION SOFTWARE FOR ROBOT CELLS	SI 16
3DRV/EV	3D DESIGN AND ANIMATION SOFTWARE FOR ROBOT CELLS	SI 17
ALEP-AD/EV	ADVANCED ELECTRO-PNEUMATICS KIT	PN 13
ALEP-BC/EV	BASIC ELECTRO-PNEUMATICS TRAINER	PN 12
ALP-PROF/EV	ELECTRO-PNEUMATICS KIT - FLOW CONTROL IN A PNEUMATIC LINE	PN 25
ALP-PROL/EV	PROPORTIONAL ELECTRO-PNEUMATICS KIT - LINEAR POSITION CONTROL	PN 23
ALP-PROV/EV	ELECTRO-PNEUMATICS KIT - SPEED CONTROL OF A PNEUMATIC MOTOR	PN 24
ALP-PSX/EV	PROXIMITY SENSORS TRAINER	PN 17
ALPE-AD/EV	ADVANCED PNEUMATICS KIT	PN 7
ALPE-BC/EV	BASIC PNEUMATICS TRAINER	PN 5
APC-900/EV	MODULAR AUTOMATIC PROCESS CONTROLS	PC 5
ATZ/EV	BOX OF TOOLS AND WORKPIECES	ME 21
AVS-1/EV	ARTIFICIAL COLOUR VISION SYSTEM	PN 19
C2-IO/EV	INTERFACE BOARD	SI 19
CO/EV	OIL-HYDRAULICS POWER UNIT	HY 6
EAT/EV	ELECTRO-PNEUMATIC ACTUATORS TRAINER	PN 15
FCBp/EV	FLOW-RATE CONTROL BENCH TOP UNIT	PC 12
FLTP/EV	PROCESS CONTROL MULTIVARIABLE SYSTEM	PC 10
HM-410/EV	ADVANCED 3-FLOOR LIFT	PL 28
HPT/EV	OIL-HYDRAULICS PROFESSOR TRAINER	HY 10
HPV-P/EV	PROPORTIONAL OIL-HYDRAULIC COMPONENTS (FOR TRAINER Mod. HPT/EV)	HY 13
HPV-S/EV	PROPORTIONAL OIL-HYDRAULIC COMPONENTS (FOR TRAINER Mod. HST/EV)	HY 17
HST/EV	OIL-HYDRAULICS STUDENT TRAINER	HY 14
HVS/EV	TRANSPARENT OIL-HYDRAULIC COMPONENTS	HY 18
ILM-V1/EV	INTELLIGENT LOGIC MODULE	PL 21
IMS/EV	PROCESS SIMULATOR FOR MOLDING PLASTIC MATERIALS	PL 15



KALEP/EV	BASIC ELECTRO-PNEUMATICS KIT	PN 15
KMEO/EV	ELECTRO-OIL-HYDRAULICS PRACTICAL SYSTEM	HY 7
KMO/EV	OIL-HYDRAULICS PRACTICAL SYSTEM	HY 5
KMOP/EV	PROPORTIONAL OIL-HYDRAULICS PRACTICAL SYSTEM	HY 8
KUB-1/EV	ROBOTIC WORKCELL	RO 5
LCBp/EV	LEVEL CONTROL BENCH TOP UNIT	PC 14
LDIDA/EV	BASIC 3-FLOOR LIFT	PL 30
LWR/EV	LIGHT WEIGHT ROBOT	RO 13
MCS-500/EV	PIECE IDENTIFICATION AND DISTRIBUTION MODULE	ME 5
MCS-505/EV	PIECES DISTRIBUTION MODULE	ME 6
MCS-510/EV	SWIVEL ARM AND MANIPULATOR MODULE	ME 7
MCS-520/EV	PIECES THICKNESS MEASUREMENT MODULE	ME 8
MCS-530/EV	LINEAR STORAGE MODULE	ME 9
MCS-570/EV	ROTARY INDEXING TABLE MODULE	ME 10
MCS-580/EV	ELECTRIC PICK AND PLACE MODULE	ME 11
MCS-590/EV	PNEUMATIC ARM MODULE	ME 12
MCS-600/EV	DRILLING STATION MODULE	ME 13
MCS-610/EV	ROTATING STORAGE MODULE	ME 14
MCS-620/EV	CARTESIAN CONTROL STORAGE MODULE	ME 15
MCS-700/EV	CONVEYOR MODULE	ME 16
MCS-710/EV	ROBOT MODULE	ME 17
MCS-720/EV	MODULE FOR TESTING AND SELECTING PIECES	ME 18
MCS-730/EV	WEIGHTING MODULE	ME 19
MCS-740/EV	STORAGE MODULE FOR PRISMATIC PIECES	ME 20
MCS-A1/EV	AUTOMATIC PIECES IDENTIFICATION AND SELECTION CENTRE CONTROLLED BY PLC	ME 24
MCS-B1/EV	AUTOMATIC PIECES IDENTIFICATION, THICKNESS MEASUREMENT AND STORAGE LINE CONTROLLED BY PLC	ME 25
MCS-C1/EV	MULTILEVEL STORAGE SYSTEM WITH PIECES IDENTIFICATION STATION ON ROTARY INDEXING TABLE IN CLOSED LOOP MODE	ME 26
MCS-D1/EV	AUTOMATIC MULTISTATION LINE FOR SAMPLES TEST AND WORKING	ME 27
MCS-E1/EV	AUTOMATIC MULTILEVEL STORAGE FOR PRODUCT SAMPLES WORKING	ME 28
MCS-F1/EV	AUTOMATIC WEIGHTING AND SELECTION SYSTEM WITH PNEUMATIC ROBOT AND DOUBLE CONVEYOR	ME 29
MCS-G1/EV	MULTILEVEL STORAGE SYSTEM WITH PIECE TESTING STATION ON ROTARY INDEXING TABLE AND CONVEYOR MODULE IN CLOSED LOOP MODE	ME 30
PCBp/EV	PRESSURE CONTROL BENCH TOP UNIT	PC 16
PCS-7/EV	DCS PROCESS CONTROL SYSTEM	PL 15
pHCBp/EV	pH CONTROL BENCH TOP UNIT	PC 20
PID-S1/EV	FOUR LOOPS PID DIGITAL CONTROLLER	PC 8
PLC-V6/EV	PLC TRAINING PANEL	PL 5
PLC-V7/EV	PLC TRAINING PANEL	PL 7
PLC-V8/EV	PLC TRAINING PANEL	PL 9
POS-PE/EV	SET OF POSTERS ON PNEUMATICS AND ELECTRO-PNEUMATICS	PN 16
PPS/EV	PACKAGING PROCESS SIMULATOR	PL 25
PPT/EV	PNEUMATICS PROFESSOR TRAINER	PN 9
PULS/EV	PUSHBUTTON PANEL	ME 22
RDIDA/EV	MANIPULATING ARM	ME 32

RV3/EV	ROBOT STATION WITH ARTIFICIAL VISION SYSTEM	RO 7
SLC/EV	SINGLE-LOOP PID DIGITAL CONTROLLER	PN 22
SMP-P/EV	SUPPLEMENTARY MODULAR PANELS (FOR TRAINER Mod. HPT/EV)	HY 12
SMP-S/EV	SUPPLEMENTARY MODULAR PANELS (FOR TRAINER Mod. HPS/EV)	HY 16
SPS/EV	IRON PROCESS SIMULATOR	PL 23
SPT/EV	PNEUMATICS STUDENT TRAINER	PN 8
SPUTK/EV	MOBILE ROBOT	RO 12
SRA/EV	AIR SERVICE UNIT	ME 21
SSP-1/EV	PROGRAMMABLE SYSTEMS SIMULATOR	PL 18
SSP-VR/EV	VIRTUAL PROCESS SIMULATION SOFTWARE	SI 18
SV-1/EV	SCADA - SUPERVISORY CONTROL AND DATA ACQUISITION - SOFTWARE FOR PID CONTROLLERS	SI 8
SV/EV	PLC SUPERVISION SOFTWARE - ADVANCED LEVEL	SI 7
SW-AIR/EV	DESIGN, SIMULATION AND ANIMATION SOFTWARE FOR THE STUDY OF PNEUMATICS AND ELECTRO-PNEUMATICS	SI 11
SW-CAI/EV	DESIGN, SIMULATION AND ANIMATION SOFTWARE FOR INDUSTRIAL AUTOMATION	SI 9
SW-ELT/EV	DESIGN, SIMULATION AND ANIMATION SOFTWARE FOR THE STUDY OF ELECTRICAL ENGINEERING	SI 15
SW-FLU/EV	DESIGN, SIMULATION AND ANIMATION SOFTWARE FOR THE STUDY OF ELECTRO-PNEUMATICS & ELECTRO OIL-HYDRAULICS	SI 14
SW-HYD/EV	DESIGN, SIMULATION AND ANIMATION SOFTWARE FOR THE STUDY OF HYDRAULICS AND ELECTRO-HYDRAULICS	SI 13
SW7/EV	PLC PROGRAMMING, SIMULATION AND SUPERVISION SOFTWARE	SI 5
T7-IOP/EV	TOUCHSCREEN OPERATOR PANEL	PL 12
T8-IOP/EV	TOUCHSCREEN OPERATOR PANEL	PL 14
TCBp/EV	TEMPERATURE CONTROL BENCH TOP UNIT	PC 18
TDIDA/EV	TEST AND SELECTION SYSTEM WITH CONVEYOR BELT	ME 33
VCPE/EV	PNEUMATICS CUT-AWAY COMPONENTS	PN 10
WT/EV	WORK-BENCH (1 DRAWER UNIT, 4 DRAWERS)	HY 9
WT2/EV	WORK-BENCH (2 DRAWER UNITS, 8 DRAWERS)	HY 9





**Elettronica Veneta S.p.A.**

Via Postumia, 16

31045 Motta di Livenza (Treviso) Italy

Tel. +39 0422 765 802 - Fax +39 0422 861 901

E-mail: [export@elettronicaveneta.com](mailto:export@elettronicaveneta.com)

[www.elettronicaveneta.com](http://www.elettronicaveneta.com)